

SV160E2 & SV400E2

Networked Integrated Servo Indexer/Driver/Motor

with Integral 2-Port Ethernet Switch and
Device Level Ring functionality for EtherNet/IP
Media Redundancy Protocol for PROFINET



User Manual

AMCI Motion Control Products

EtherNet/IP™



GENERAL INFORMATION

Important User Information

The products and application data described in this manual are useful in a wide variety of different applications. Therefore, the user and others responsible for applying these products described herein are responsible for determining the acceptability for each application. While efforts have been made to provide accurate information within this manual, AMCI assumes no responsibility for the application or the completeness of the information contained herein.

UNDER NO CIRCUMSTANCES WILL ADVANCED MICRO CONTROLS, INC. BE RESPONSIBLE OR LIABLE FOR ANY DAMAGES OR LOSSES, INCLUDING INDIRECT OR CONSEQUENTIAL DAMAGES OR LOSSES, ARISING FROM THE USE OF ANY INFORMATION CONTAINED WITHIN THIS MANUAL, OR THE USE OF ANY PRODUCTS OR SERVICES REFERENCED HEREIN.

No patent liability is assumed by AMCI, with respect to use of information, circuits, equipment, or software described in this manual.

The information contained within this manual is subject to change without notice.

This manual is copyright 2021 by Advanced Micro Controls Inc. You may reproduce this manual, in whole or in part, for your personal use, provided that this copyright notice is included. You may distribute copies of this complete manual in electronic format provided that they are unaltered from the version posted by Advanced Micro Controls Inc. on our official website: www.amci.com. You may incorporate portions of this documents in other literature for your own personal use provided that you include the notice "Portions of this document copyright 2021 by Advanced Micro Controls Inc." You may not alter the contents of this document or charge a fee for reproducing or distributing it.

Standard Warranty

ADVANCED MICRO CONTROLS, INC. warrants that all equipment manufactured by it will be free from defects, under normal use, in materials and workmanship for a period of [18] months. Within this warranty period, AMCI shall, at its option, repair or replace, free of charge, any equipment covered by this warranty which is returned, shipping charges prepaid, within eighteen months from date of invoice, and which upon examination proves to be defective in material or workmanship and not caused by accident, misuse, neglect, alteration, improper installation or improper testing.

The provisions of the "STANDARD WARRANTY" are the sole obligations of AMCI and excludes all other warranties expressed or implied. In no event shall AMCI be liable for incidental or consequential damages or for delay in performance of this warranty.

Returns Policy

All equipment being returned to AMCI for repair or replacement, regardless of warranty status, must have a Return Merchandise Authorization number issued by AMCI. Call (860) 585-1254 with the model number and serial number (if applicable) along with a description of the problem during regular business hours, Monday through Friday, 8AM - 5PM Eastern. An "RMA" number will be issued. Equipment must be shipped to AMCI with transportation charges prepaid. Title and risk of loss or damage remains with the customer until shipment is received by AMCI.

24 Hour Technical Support Number

24 Hour technical support is available on this product. If you have internet access, start at www.amci.com. Product documentation and FAQ's are available on the site that answer most common questions.

If you require additional technical support, call (860) 585-1254. Your call will be answered by the factory during regular business hours, Monday through Friday, 8AM - 5PM Eastern. During non-business hours an automated system will ask you to enter the telephone number you can be reached at. Please remember to include your area code. The system will page an engineer on call. Please have your product model number and a description of the problem ready before you call.

Waste Electrical and Electronic Equipment (WEEE)



At the end of life, this equipment should be collected separately from any unsorted municipal waste.

TABLE OF CONTENTS

General Information

Important User Information	2
Standard Warranty	2
Returns Policy	2
24 Hour Technical Support Number	2
WEEE Statement	2

About this Manual

Audience	7
Applicable Units	7
Navigating this Manual	7
Manual Conventions	8
Trademarks Notices	8
Revision Record	8
Revision History	8
Manual Layout	9

Reference: AMCI SV Servo Specifications

E2 Product Family	11
The SV Servo Family	11
Network Data Format	11
General Functionality	12
Safe Torque Off Functionality	12
Electromechanical Brake Option ...	13
Specifications	14
Indexer Functionality	15
Driver Functionality	15
Servo Control	16
Absolute Encoder	17
Stall Detection	17
Available Discrete Inputs	17
Home Input	17
CW Limit Switch or	
CCW Limit Switch	17
Trap Encoder Position &	
Start Indexed Move Input	18
Emergency Stop Input	18
Stop Jog or Registration Move	18
General Purpose Input	18
Enabling the Driver	18
STO Option	19
Software Monitoring	19
Stop Category 0	19
Discrepancy Timer Limit	19
Status Bits	20
State Diagrams	20

Reference: AMCI SV Servo Specifications (continued)

Status LED's	22
Drive Status LED	22
Module Status (MS) LED	22
Network Status (NS) LED	23
SV Servo Connectors	23
Ethernet Connectors	23
Digital Inputs Connector	24
Power Connector	24
Brake Connector	25
Torque Curves	25
Power Supply Sizing	26
Regeneration (Back EMF) Effects	27
Compatible Connectors and Cordsets	27
Ethernet Connector	27
Input Connector	27
Power Connector	27
Brake Connector	28
Ethernet Cordset	28
Input Cordset	28
Power Cordset	28
Brake Cordset	28

Reference: Motion Control

Definitions	29
Units of Measure	29
Profile Position	29
Encoder Position	29
Continuous Torque	29
Peak Torque	29
Home Position	30
Count Direction	30
Target Position	30
Relative Coordinates	30
Absolute Coordinates	30
Immediate Stop Deceleration	30
A Simple Move	31
Controlled and Immediate Stops	32
Host Control	32
Hardware Control	32
Basic Move Types	33
Relative Move	33
Controlled Stops	33
Immediate Stops	33

Reference: Motion Control

Absolute Move 34
 Controlled Stops 34
 Immediate Stops 34
 CW/CCW Jog Move 35
 Controlled Stops 35
 Immediate Stops 35
 CW/CCW Registration Move 36
 Controlled Stops 37
 Immediate Stops 37
 Indexed Moves 38
 Axis Follower Moves 39
 Controlling Moves In Progress 40
 Jog Moves 40
 Registration Moves 40
 Absolute and Relative Moves 40
 Disabling the Motor 40

Reference: Move Profile Calculations

Constant Acceleration Equations 41
 Variable Definitions 41
 Total Time Equations 43

Reference: Homing an SV Servo Controller

Definition of Home Position 45
 Definition of Homing Speed 45
 Position Preset 45
 CW/CCW Find Home Commands 45
 Homing Inputs 45
 Homing Configurations 45
 Homing Profiles 46
 Home Input Only Profile 46
 Profile with Overtravel Limit 47
 Controlling Find Home
 Commands In Progress 48
 Controlled Stops 48
 Immediate Stops 48

Reference: Configuration Mode Data Format

Modes of Operation 49
 Configuration Mode 49
 Command Mode 49
 Power Up Behavior 49
 Data Format 49
 Command Mode Data Formats 50
 PID Gain Calculations 50

Reference: Configuration Mode Data Format (continued)

Output Data Format 51
 Configuration Word 0 Format 51
 Read Data Blocks 53
 Extended Drive Status 53
 Remaining Read Data Blocks 53
 Write Data Blocks 54
 Block 1: Data Configuration Block 54
 Block 2: I/O Configuration Block 54
 Block 3: Motor Configuration Block 55
 Block 5: Velocity Control Loop
 Configuration Block 56
 Block 6: Position Control Loop
 Configuration Block 58
 Block 15: Save Configuration
 To Flash Block 59
 Input Data Format 59
 Configuration Mode
 Input Word 0 59
 Configuration Mode
 Input Word 1 60
 Invalid Configurations 61

Reference: Command Mode Data Format

Command Bits Must Transition 63
 Data Format 63
 Output Data Format 63
 Command Word 0 64
 Command Word 1 65
 Command Blocks 66
 Absolute Move 66
 Relative Move 67
 Hold Move 67
 Resume Move 68
 Immediate Stop 68
 Find Home CW 69
 Find Home CCW 69
 Jog CW 70
 Registration Move CW 70
 Axis Follower Moves 71
 Jog CCW 72
 Registration Move CCW 72
 Preset Position 73
 Reset Errors 73
 Enable Driver or Preset On Enable 74
 Disable Driver 74

Reference: Command Mode Data Format (continued)

Input Data Format	75
Profile Position	75
Encoder Position	75
Trapped Encoder Position	75
Actual Motor Current	75
Actual Motor Velocity	76
Status Word 0 Format	76
Status Word 1 Format	77
Notes on Clearing a Driver Fault	79

Chapter 7: Braking Resistor Calculations

Overvoltage Threshold Parameter	81
Required Information	81
Step 1: Determine Regenerative Power Capability	82
Step 2: Determine System Inertia	82
Step 3: Determine the Deceleration Rate	82
Step 4: Determine Peak Braking Power ..	83
Step 5: Determine Minimum Braking Resistor Value	83
Step 6: Determine Maximum Braking Resistor Value	83
Step 7: Determine Average Power Rating	84
Determining the Braking Resistor	84

Reference: Configuring Network Interfaces

Firewall Settings	85
Disable All Unused Network Interfaces ..	85
Configure Your Network Interface	85
Test Your Network Interface	86

Task: Installing an SV Servo

Location	87
Safe Handling Guidelines	87
Prevent Electrostatic Damage	87
Prevent Debris From Entering the Unit	87
Remove Power Before Servicing ..	87
Operating Temperature Guidelines	87

Task: Installing an SV Servo (continued)

STO General Installation Guidelines	88
Qualified Personnel	88
Remain Within the Environmental Limits	88
Properly Use Inputs	
STOA and STOB	88
Consulting Services	88
Mounting an SV Servo	88
SV160E2 Outline Drawing	89
SV400E2 Outline Drawing	90
SV Servo Mounting	91
Connecting the Load	91
Mounting an SV Servo with Brake Option	91
SV160E2-B Outline Drawing	92
SV400E2-B Outline Drawing	93
SV160E2-B/SV400E2-B Mounting	93
Connecting the Load	94
Power Connector	94
Compatible Connectors and Cordsets	95
Power Wiring	95
Input Connector	96
Compatible Connectors and Cordsets	96
CNFL-5M Color Code and Shield Wire	97
Cable Shields	97
DC Input Wiring	98
Sinking Sensors Require a Pull Up Resistor	98
STO Input Wiring	99
Extending the STO Cabling	99
SV Servo Brake Connector	99
Compatible Cordsets and Connectors	100
Brake Wiring	100
Network Connectors	101
Compatible Connectors and Cordsets	101
TIA/EIA-568 Color Codes	101
EtherNet/IP Connections	102
Non-DLR Applications	102
DLR Applications	102
PROFINET Connections	102
Non-MRP Applications	102
MRP Applications	102

**Task: Installing an SV Servo
(continued)**

Modbus TCP Connections 102
 STO Commissioning 103
 When to run the tests 103
 Basic commissioning test outline . 103
 Commissioning test outline -
 Discrepancy Timer Limit = 0 103
 Commissioning test outline -
 Discrepancy Timer Limit <> 0. .. 104

**Task: Set the IP Address and
Protocol**

Determine the Best Method for
 Setting the IP Address 107
 Use Factory Default Settings 107
 Use the Embedded Web Server 108
 Use the AMCI NET Configurator Utility 111

**Task: Implicit Communications
with an EDS**

Obtain the EDS file 115
 Install the EDS file 115
 Start the EDS Hardware
 Installation Tool 115
 Install the EDS File 116
 Host System Configuration 118
 Add the SV Servo to Your Project 118
 SV Servo Properties Setup 119
 General Tab 119
 Connection Tab 119
 Configuration Tab 119
 Buffering the I/O Data 120

**Task: EtherNet/IP Explicit
Messaging**

Required Message Instructions 121
 Create Four New Data Files. 121
 Add the Message Instructions
 to your Ladder Logic 122
 Troubleshooting 125

Task: Modbus TCP Configuration

Enable Modbus TCP Protocol 127
 Modbus Addressing 127
 Modbus Table Mapping 127
 Host Addressing 127
 AMCI Modbus TCP Memory Layout 128
 Supported Number of Connections 128
 Supported Modbus Functions 129
 Supported Modbus Exceptions 129

**Task: PROFINET Network
Configuration**

Basic Steps 131
 Download the GSDML files 131
 GSDML File Installation 131
 Configure the PROFINET Network 131
 Add the SV Servo to the
 PROFINET Network 132
 Configure the SV Servo 134
 Set the I/O Configuration 135
 Set the SV Servo Device Name 136
 Verify and Download the
 New Configuration 136
 MRP Installations 137
 Configure the SV Servo as an MRC 137

ABOUT THIS MANUAL

Read this chapter to learn how to navigate through this manual and familiarize yourself with the conventions used in it. The last section of this chapter highlights the manual's remaining chapters and their target audiences.

Audience

This manual explains the installation and operation of AMCI's SV160E2 and SV400E2 Integrated Servo Motors. It is written for the engineer responsible for incorporating these products into a design as well as the engineer or technician responsible for their actual installation.

Applicable Units

This manual applies to all of the units in the SV Integrated Servo Motor family. Each unit contains a two port Ethernet switch, which simplifies network wiring. When the EtherNet/IP protocol is used, the unit can act as a node in a Device Level Ring (DLR). When PROFINET is enabled, the unit supports the Media Redundancy Protocol (MRP) and can be incorporated in PROFINET installations that use a redundant ring topology.

In this manual, the term "SV Servo" is used when the information applies equally to the SV160E2 and SV400E2 products lines. The complete part number is used when information applies only to one of the product lines. This includes such information as outline drawings and suggested PID loop settings.

Navigating this Manual

This manual is designed to be used in both printed and on-line forms. Its on-line form is a PDF document, which requires Adobe Acrobat Reader version 7.0+ to open it. You are allowed to select and copy sections for use in other documents and add notes and annotations. If you decide to print out this manual, all sections contain an even number of pages which allows you to easily print out a single chapter on a duplex (two-sided) printer.

Manual Conventions

Three icons are used to highlight important information in the manual:



NOTES highlight important concepts, decisions you must make, or the implications of those decisions.



CAUTIONS tell you when equipment may be damaged if the procedure is not followed properly.



WARNINGS tell you when people may be hurt or equipment may be damaged if the procedure is not followed properly.

The following table shows the text formatting conventions:

Format	Description
Normal Font	Font used throughout this manual.
<i>Emphasis Font</i>	Font used for parameter names and the first time a new term is introduced.
<i>Cross Reference</i>	When viewing the PDF version of the manual, clicking on a blue cross reference jumps you to referenced section of the manual.
<i>HTML Reference</i>	When viewing the PDF version of the manual, clicking on a red cross reference opens your default web browser to the referenced section of the AMCI website if you have Internet access.

Manual Conventions

Trademarks Notices

The AMCI logo is a trademark of Advanced Micro Controls Inc. “CIP” is a trademark of Open DeviceNet Vendor Association, Inc. “EtherNet/IP” is a trademark of ControlNet International, Ltd. under license by Open DeviceNet Vendor Association, Inc. “PROFINET” is a registered trademark of PROFIBUS & PROFINET International (PI). “Adobe” and “Acrobat” are registered trademarks of Adobe Systems Incorporated.

All other trademarks contained herein are the property of their respective holders.

Revision Record

This manual, 940-0S255 is the sixth release of this manual. It was released on May 19th, 2022. It corrects dimensional drawings of the SV400E2 products and makes correction through out the manual.

Revision History

- 940-0S254: August 18th, 2021 - Adds SV400E2 and STO testing guidelines.
- 940-0S253: February 22nd, 2021 - Updates IP rating and adds electromechanical brake option information.
- 940-0S252: April 13th, 2020 - Improves information on STO option.
- 940-0S251: September 10th, 2019 - Improved Virtual Axis Move information. Updates torque curve drawing
- 940-0S250: August 23rd, 2019 - Initial Release

Manual Layout

You will most likely read this manual for one of two reasons:

- ▶ If you are curious about the Integrated Servo Motor products from AMCI, this manual contains the information you need to determine if these products are the right products for your application. The first chapter, *AMCI SV Servo Specifications* contains all of the information you will need to fully specify the right product for your application.
- ▶ If you need to install and use an Integrated Servo Motor product from AMCI, then the rest of the manual is written for you. To simplify installation and configuration, the rest of the manual is broken down into *references* and *tasks*. Using an Integrated Servo Motor product requires you to complete multiple tasks, and the manual is broken down into sections that explain how to complete each one.

Section Title	Page Num.	Section Description
<i>AMCI SV Servo Specifications</i>	11	Complete specifications for the SV160E2 and SV400E2 products.
<i>Motion Control</i>	29	Reference information on how the SV160E2 or SV400E2 can be used to control motion in your application.
<i>Move Profile Calculations</i>	41	Reference information on calculating detailed move profiles.
<i>Homing an SV Servo Controller</i>	45	Reference information on how to set the home position of the SV160E2 or SV400E2.
<i>Configuration Mode Data Format</i>	49	Reference information on the format of the network data to and from the SV Servo unit that is used to configure it.
<i>Command Mode Data Format</i>	63	Reference information on the format of the network data to and from the SV Servo unit that is used to command it.
<i>Braking Resistor Calculations</i>	81	Calculations required to size the braking resistor for proper power dissipation during deceleration.
<i>Configuring Network Interfaces</i>	85	Basic instructions for the task of configuring network interfaces on your computer or laptop.
<i>Installing an SV Servo</i>	87	Task instructions covering how to install an SV160E2 or SV400E2 on a machine. Includes information on mounting, grounding, and wiring specific to the units.
<i>Set the IP Address and Protocol</i>	107	Task instructions that covers the options for setting the IP address and protocol on an SV Servo unit.
<i>Implicit Communications with an EDS</i>	115	Task instructions that cover how to add an SV Servo unit to an EtherNet/IP host that supports the use of EDS files.
<i>EtherNet/IP Explicit Messaging</i>	121	Task instructions for adding message instructions to you host controller program that write data to the SV Servo unit through message instructions.
<i>Modbus TCP Configuration</i>	127	Task instructions for communicating with an SV Servo unit using the Modbus TCP protocol.
<i>PROFINET Network Configuration</i>	131	Task instructions that covers how to add an SV Servo unit to a PROFINET network.

Manual Sections

Notes

AMCI SV SERVO SPECIFICATIONS

This manual is designed to get you up and running quickly with an SV160E2 or SV400E2 product from AMCI. As such, it assumes you have some basic knowledge of servo systems.

E2 Product Family

The SV160E2 and SV400E2 product lines are additions to the family of E2 products from AMCI. E2 products incorporate *E2 Technology*, a common Ethernet network interface that allows them to operate over the EtherNet/IP, Modbus TCP, and PROFINET industrial networks. The E2 product family encompasses stepper and servo integrated motion control products, resolver based encoder products, and specialty I/O products for sensor interface and motion control.

The SV Servo Family

The SV Servo units combine a servo indexer, driver, and a BLDC motor into a product that can be attached to any popular industrial network. Each SV Servo attaches to your Ethernet network and communicates using the EtherNet/IP, Modbus TCP, or PROFINET protocols.

E2 Technology products are simple and intuitive, allowing easy transition between multiple common industrial Ethernet protocols without the need to physically switch parts. An advanced web server integrated into all AMCI E2 Technology devices facilitates simple device configuration and troubleshooting via a web-browser. Furthermore, an impressive array of advanced features for each supported protocol has been incorporated into the devices to meet many unique application requirements.

Each unit has two Ethernet ports which are internally connected through an onboard, two port, 10/100 Mbps ethernet switch. These ports allow you to wire your network in a “daisy-chain” fashion, which may lower network wiring costs and complexities.

The two ports also allows units to function as members of a redundant Device Level Ring (DLR) network when using the EtherNet/IP protocol or as clients in a Media Redundancy Protocol (MRP) network when using PROFINET.

In DLR environments, the SV Servo units act as Beacon-Based Ring Nodes. All units can process beacon packets at the default rate of every 400 microseconds. Beacon-based nodes can respond faster to network changes than nodes that only process Announce packets.

Network Data Format

In order to support any host that communicates with the EtherNet/IP, PROFINET, or Modbus TCP protocols, the format of the 32 bit integer values read from and written to the SV Servo is programmable. The parameter, called *Data Endian*, controls the order of the two 16-bit words in the 32 bit value. Least significant word first is called *little endian*, most significant word first is called *big endian*. Rockwell Automation controllers use *little endian* format, while the default PROFINET and Modbus format is *big endian*.

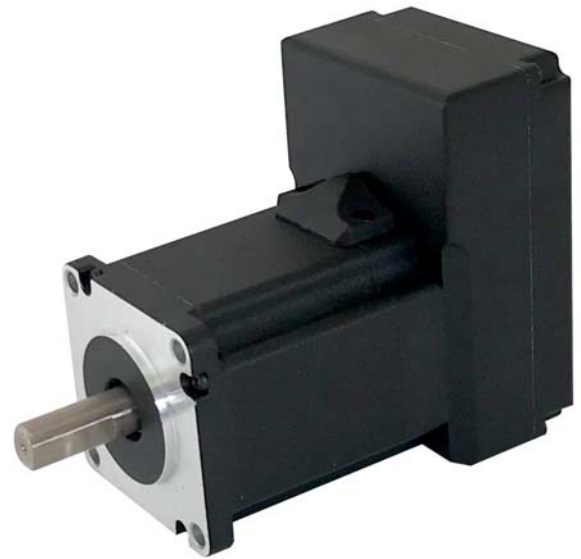

Figure R1.1 SV160E2

The SV Servo Family (continued)

General Functionality

Each AMCI SV Servo product has four integrated parts:

- An indexer that accepts commands over an Ethernet connection using the EtherNet/IP, PROFINET, or Modbus TCP protocol
- A high current BLDC driver that accepts 48 to 80 Vdc as its input power source
- A high torque 160 watt or 400 watt BLDC motor
- An absolute multi-turn encoder.

The availability of the EtherNet/IP, PROFINET, and Modbus TCP protocols makes the SV Servo units easy to integrate into a wide variety of control systems.

This combination of host and driver gives you several advantages:

- Sophisticated I/O processing can be performed in the host (PLC or other controller) before sending commands to the SV Servo unit
- All motion logic is programmed in the host, eliminating the need to learn a separate motion language
- The integral two port Ethernet switch simplifies network cabling
- The DLR interface eliminates single point failures in EtherNet/IP environments
- The MRP interface eliminates single point failures in PROFINET environments.

An SV Servo is powered by a nominal 48 to 80 Vdc power source, and can accept surge voltages of up to 100 Vdc without damage. The continuous motor torque is fully programmable with the Continuous Torque Limit parameter. The peak motor torque, which is used during times of acceleration and deceleration, is fully programmable with the Peak Torque Limit parameter. These programmable torque settings makes the SV Servos suitable to a wide range of applications.

Units	Continuous Torque Limit	Peak Torque Limit
SV160E2	0.10 Nm to 0.50 Nm	1.30 Nm maximum
SV400E2	0.25 Nm to 1.28 Nm	3.50 Nm maximum

Figure R1.2 Torque Limits

The SV Servo units have four 12 to 24 Vdc inputs that are used by the indexer. Configuration data from the host sets the function of these inputs. Each input can be individually configured as a:

- CW or CCW Limit Switch
- Home Limit Switch
- Trap Position Input (Will trap the current encoder position.)
- Stop Jog or Registration Move Input
- Start Indexed Move
- Emergency Stop Input
- General Purpose Input

Safe Torque Off Functionality

The SV Servo units can be ordered with STO (Safe Torque Off) functionality under the part number SV160E2-STO or SV400E2-STO. Safe Torque Off allows you to remove power from the motor without removing power from the drive. This reduces implementation costs and restart times.

The STO functionality requires two dedicated inputs. The SV Servo units use inputs 3 and 4. When an SV160E2-STO or SV400E2-STO is ordered, additional circuitry is added to these inputs for the STO functionality. This additional circuitry makes the inputs unsuitable for other functions such as sensing end of travel or home position.

The SV Servo Family (continued)**Safe Torque Off Functionality (continued)**

STO is a hardware only solution and is not dependant on software running within the SV Servo unit. Both of the STO inputs must be powered by a 12 to 24 Vdc source to enable the drive. When power is removed from either of these inputs, power to the motor is directly removed from the power stage through the additional circuitry. The machine will come to an uncontrolled coasting stop if the motor was in motion when the STO feature triggered. Power remains removed from the motor until the inputs are reactivated, the fault status bits are cleared, and the driver is re-enabled from the host controller.

Electromechanical Brake Option

The SV Servo units can be ordered with a factory installed 24 Vdc electromechanical brake. This option is denoted by adding a '-B' to the end of the part number. e.g. SV160E2-B or SV400E2-STOB. The brake applies 1.5N of holding torque, and 24 Vdc must be applied to release the brake.

Specifications

Network Interface

10/100baseT. Two switched ports.
 Supports EtherNet/IP, PROFINET, and Modbus TCP. EtherNet/IP-DLR and PROFINET-MRP extensions also supported.

Physical Dimensions

See page 89

Weight

SV160E2: 3.4 lbs. (1.5 kg.)
 SV400E2: 4.0 lbs. (1.8 kg.)

Weight is without mating connectors

Maximum Shaft Loads

Radial: 45 lbs. (200N) at end of shaft
 Axial: 13.5 lbs. (60N)

Maximum Operating Temperature

203°F /95°C (Note that this is the operating temperature of the electronics, not maximum ambient temperature. An over-temperature fault occurs at this point and current is removed from the motor.)

Motor Counts per Turn

16,384

Internal Encoder

Absolute 31 bit multi-turn encoder 16,384 counts per turn.

Inputs

Electrical Characteristics:
 Single ended sinking.
 Accept 10.6 to 27 Vdc without the need for an external current limiting resistor. Optoisolated, 1500 Vac/dc isolation.

Motor Inertia

SV160E2: $48 \times 10^{-6} \text{ kg}\cdot\text{m}^2$
 SV400E2: $29 \times 10^{-6} \text{ kg}\cdot\text{m}^2$

Continuous Torque

Programmable in 0.01 Nm steps.
 SV160E2: 0.10 to 0.50 Nm
 SV400E2: 0.25 to 1.28 Nm

Peak Torque

Programmable in 0.01 Nm steps.
 SV160E2: Continuous Torque to 1.30 Nm.
 SV400E2: Continuous Torque to 3.50 Nm.

Torque Constant

SV160E2: 0.124 Nm/Arms
 SV400E2: 0.136 Nm/Arms

Torque can be estimated by: Torque Constant x 0.7071 x the peak motor current reported in the Network Input Data.

STO Safety Ratings

IEC 61508: SIL3
 EN ISO 13849-1: PLd

Environmental Specifications

Input Power 48 to 80 Vdc, surge to 100 Vdc without damage to unit.

Ambient Operating Temperature
 -40° to 122°F (-40° to 50°C)

Storage Temperature
 -40° to 185°F (-40° to 85°C)

Humidity 0 to 95%, non-condensing

IP Rating IP50

Status LED's

See [Status LED's](#) section starting on page 22.

Connectors and Cables

All mating connectors are available separately under the following AMCI part numbers.

Connector	AMCI Part #	Wire	Strip Length	Connection Type
Ethernet	MS-28	18 AWG max.	0.197 inches	Screw Terminals
I/O	MS-37	20 AWG max.	0.197 inches	Screw Terminals
Power	MS-41	16 AWG max.	0.197 inches	Screw Terminals

Cable	AMCI Part #	Length
Ethernet	CNER-5M	5 meter
Digital I/O	CNFL-5M	5 meter
Power	CNGL-5M	5 meter

Indexer Functionality

The table below lists the functionality offered by the indexer built into the AMCI SV Servo units.

Feature	Description
Multiple Network Protocols	The SV Servo units can be configured to communicate with EtherNet/IP, PROFINET, or Modbus TCP protocols. This allows easy setup and communication with a wide range of host controllers.
EtherNet/IP-DLR	The SV Servo units act as Beacon-Based Nodes in Device Level Ring environments. This functionality results in the fastest response to changes in the redundant network.
PROFINET-MRP	SV Servo units have Media Redundancy Protocol support, which adds redundancy to the PROFINET protocol.
Programmable Inputs	Each of the inputs can be programmed as a Home Limit, Over Travel Limit, Trap Input, Manual Jog Stop, Start Indexed Move, E-Stop, or a General Purpose Input.
Programmable Parameters	PID variables, running speed, acceleration, and deceleration, are fully programmable.
Homing	Allows you to set the machine to a known position. An SV Servo homes to a discrete input.
Jog Move	Allows you to drive the motor in either direction as long as the command is active.
Axis Follower Move	Allows you to treat the SV Servo unit as a motion axis by constantly updating position and velocity data to the unit. Linear and Circular axes are both supported.
Relative Move	Allows you to drive the motor a specific number of counts in either direction from the current location.
Absolute Move	Allows you to drive the motor from one known location to another known location.
Registration Move	Allows you to jog the motor in either direction based on a command from your host controller. When a controlled stop is issued, the move will continue for a programmable number of steps before coming to a stop.
Indexed Move	Allows you to command a move that is run only when one of the programmable inputs makes a transition.
Hold Move	Allows you to suspend a move, and optionally restart it, without losing your position value.
Resume Move	Allows you to restart a previously held move operation.
Immediate Stop	Allows you to immediately stop all motion if an error condition is detected by your host controller.

Table R1.1 Indexer Functionality

Driver Functionality

This table summarizes the features of the servo motor driver portion of the SV Servo units.

Feature	Benefits
Continuous and Peak Torque Control	Continuous and peak torque control give an SV Servo unit the ability to drive the motor at its rated steady state power limit as well as increase its torque output during times of acceleration and deceleration.
Over Temperature Detection	An SV Servo unit sets a warning bit in the network data when the internal temperature of the unit approaches its safe operating threshold.
Over Temperature Protection	Protects your SV Servo unit from damage by removing power from the motor if the internal temperature of the driver exceeds the safe operating threshold of 203°F/95°C.

Table R1.2 Driver Functionality

Servo Control

Each AMCI SV Servo unit uses three control loops to control the position and velocity of the motor. The inner most loop is the current loop. The optimum PID values for the current loop are solely dependant on motor characteristics. These values are set at the factory during the final test of the SV Servo unit and are stored in the device’s flash memory. In order to simplify programming, these current loop values are not available to the end user since they are optimized at the factory.

The next inner loop is the velocity loop. This is implemented as a PI loop that includes a programmable low pass filter on the velocity feedback. This filter is used to reduce high frequency stability issues that may exist in some applications.

The outer most loop is the position loop. This is a full PID loop that generates the velocity setpoint for the velocity PI loop.

The position setpoint, SP_{POS} in the figure below, is generated and updated by the SV Servo through the motion profile generator. The velocity feed forward value, FF_{VEL} in the figure below, is also generated by the motion profile generator.

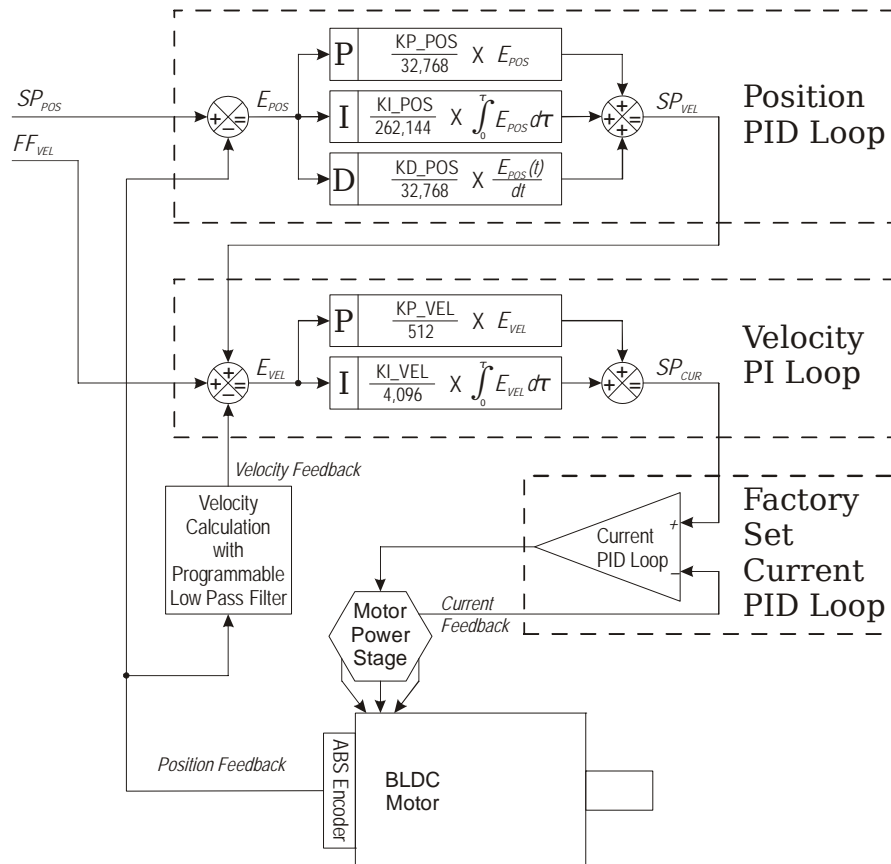

Figure R1.3 Cascade PID Loop Control

The P, I, and D variables of the position loop, as well as the P and I variables of the velocity loop, can be directly programmed as part of the configuration data. This gives the end user the ability to fine tune parameters in applications that require the highest performance levels. This can also complicate system startup. To simplify the startup procedure as much as possible, starting values for these variables are published later in this manual for load inertia values from one to twenty times the motor inertia value.

In addition to the values listed above, the position loop also has “At Rest” P and I variables. In systems where the load is not tightly coupled to the motor, such as belt driven systems, the Position Loop PID Gains may cause oscillations at zero speed. In these systems, the At Rest P and I values can be programmed and they will be used when the velocity equals zero.

Absolute Encoder

The absolute encoder has a fixed resolution of 16,384 counts per turn. The absolute encoder is a multi-turn device that encodes a total of 2^{17} turns, yielding a full thirty-one bits of position resolution. The Profile and Encoder positions are reported back with a range of $\pm 2^{30}$ counts, and range from -1,073,741,824 to 1,073,741,823

Like many intelligent absolute encoders on the market today, the absolute encoder in the SV Servo units uses a battery backed circuit to count zero crossings while power is removed from the rest of the device. The battery life is 10 years in the absence of power. The circuit will accurately track position as long as the shaft acceleration is limited to 160,000 degrees/sec², (444.4 rev/sec²), or less.

Stall Detection

A motor stall is detected when the Encoder Position differs from the calculated Profile Position by a programmed amount. This amount is programmed with the Maximum Position Error Limit parameter. Stalls can occur because the programmed Continuous Torque Limit or Peak Torque Limit values are set too low, the move's programmed acceleration or deceleration values are set too high, or the loads' torque requirements have increased due to a mechanical change in the system.

When a stall is detected:

- 1) The Stall_Detected bit is set in the data reported to the host controller.
- 2) The Profile Position is set equal to the Encoder Position.
- 3) The SV Servo performs an immediate stop. The rate of deceleration during an immediate stop is programmable with the Immediate Stop Deceleration parameter. The immediate stop deceleration can be programmed from 1,500,000 steps/sec² to 15,999,000 steps/sec². The SV Servo will stop all motion immediately if the Immediate Stop Deceleration parameter is set to zero.
- 4) Once the immediate stop completes, the SV Servo checks the difference between the Encoder Position and calculated Profile Position. If the error is less than the programmed Maximum Position Error Limit parameter the motor will stay enabled. If the error exceeds the Maximum Position Error Limit parameter, the motor is disabled and a Position_Invalid bit is set to "1" to signal the host controller of the error.

Available Discrete Inputs

The standard SV Servo unit has four discrete DC inputs, Inputs 1 - 4. The SV Servo units with the STO option has two discrete DC inputs, Inputs 1 and 2, in addition to its two STO inputs. These non-STO discrete DC inputs accept a nominal 12 to 24 Vdc signal and their functionality is fully programmable. The active state of each input is also programmable. Programming their active states allow them to act as Normally Open (NO) or Normally Closed (NC) contacts. All of these inputs are open collector sinking and share their common connection. The remainder of this section describes the available functionality.

Home Input

Many applications require that the machine be brought to a known position before normal operation can begin. This is commonly called "homing" the machine or bringing the machine to its "home" position. An SV Servo unit allows you to define this starting position in two ways. The first is with a Position Preset command. The second is with a sensor mounted on the machine. When you define one of the inputs as the Home Input, you can issue commands to the SV Servo that will cause the unit to seek this sensor. How the SV Servo actually finds the home sensor is described in the reference chapter *Homing an SV Servo Controller* starting on page 45.

CW Limit Switch or CCW Limit Switch

Each input can be defined as a CW or CCW Limit Switch. When used this way, the inputs are used to define the limits of mechanical travel. For example, if you are moving in a clockwise direction and the CW Limit Switch activates, all motion will immediately stop. At this point, you will only be able to jog in the counter-clockwise direction.

Available Discrete Inputs (continued)

Trap Encoder Position & Start Indexed Move Input

An inactive-to-active transition on this input will trap the current encoder position and report it in the Network Input Data. If an Indexed Move is pending, the transition will also start the move. Indexed Moves are programmed through the Network Data like every other move. The only difference is that Indexed Moves are not run until a Start Indexed Move Input makes an inactive-to-active state transition. This allows an SV Servo unit to run critically timed moves that cannot be reliably started from the network due to data transfer lags.

Emergency Stop Input

When an input is defined as an Emergency Stop, or E-Stop, Input and it is activated, motion will come to an Immediate Stop. The move cannot be restarted. The *Immediate Stop Deceleration* parameter, described on page 30, is used to decelerate the load. If a stall is not detected during the stop, the motor will return to the Profile Position value. If a stall is detected during the stop, the SV Servo will disable the motor and issue a Position_Invalid fault. See *Stall Detection* on page 17 for a description of the stall detection process.

Any move, including a Jog or Registration Move, cannot begin while this input is active.

Stop Jog or Registration Move

When an input is configured as a Stop Jog or Registration Move Input, triggering this input during a Jog Move or Registration Move will bring the move to a controlled stop and trap the encoder position. The controlled stop and encoder position trap is triggered on an inactive-to-active state change on the input. Only Jog Moves and Registration Moves can be stopped this way, all other moves ignore this input.

General Purpose Input

If your application does not require one or more of the inputs, you can configure the unused inputs as General Purpose Inputs. The inputs are not used by the SV Servo, but their on/off state is reported in the network data and is available to your host controller.

Enabling the Driver

Each SV Servo unit performs multiple checks before enabling power to the motor.

- The unit must be in Command Mode.
- A Configuration error must not exist.
- The unit must pass its internal checks. (The Module_OK status bit must equal “1”.)
- The power stage must not be in an over temperature or over current condition.
- The DC Bus Voltage must be between 19 Vdc and 95 Vdc.
 - When using the Over Voltage Threshold parameter, the input voltage must be less than 90% of this value. (If the Threshold is set to 79.2 Vdc, the input voltage cannot exceed $79.2 \times 0.9 = 72$ Vdc.)
- If configured, an Emergency Stop input must not be active.
- The encoder must pass its operational checks and actively provide a valid position
- The difference between the Profile Position and the Encoder Position must be less than $\pm 4,096$ counts or the Preset_On_Enable bit must be set. (When set, the Profile Position is set to the Encoder Position when the motor is enabled.)
- On STO units, the STO_Active and STO_Failure bits must both be “0”. (See below for a description of the STO Option.)

STO Option

As stated previously, the STO option adds additional circuitry that allows power to be removed from the power stage of the motor directly. This is a hardware only solution. If either of the two redundant inputs is inactive, power is removed. This state cannot be overridden by software control.

NOTE  The STO functionality has not yet been approved by any third party laboratory. This process is pending.

The STO operation of each SV Servo unit meets the following safety requirements. These ratings are based on self-assessment and design-based calculation of MTBF.

Parameter	Value
Stop Category IEC 60204-1	Stop Category 0
SIL (Safety Integrity Level) IEC 61508	SIL3
Performance Level (PL) EN ISO 13849-1	PLd

Inputs 3 and 4 are used as the redundant STO inputs. When an SV Servo is ordered with the STO functionality, additional components are added to the PC board that directly connects these two inputs to the power stage of the motor.

Software Monitoring

An SV Servo unit with the STO option reports two additional status bits to the host controller; STO_Active, and STO_Failure. Note that the software only acts as a monitor. The STO inputs will disable the motor even if there is a failure in software execution.

Stop Category 0

The SV160-STO and SV400-STO units comply with Stop Category 0 as defined in the IEC 60204-1 specification. Power is removed from the motor when the STO function is on. The motor cannot generate torque. If moving, the motor will coast to an uncontrolled stop.

These units do not support Stop Category 1 or 2 as defined in the IEC 60204-1 specification.

WARNING  The motor cannot generate torque when the STO function is on. A vertical load can drop when the STO function is active. This may be dangerous to equipment and people. Your machine design must account for this possibility. For example, install an external electro-mechanical brake that activates with the STO.

Discrepancy Timer Limit parameter

One additional software parameter is available on the STO units, the *Discrepancy Timer Limit*. This parameter has a range of 50 to 3,000, with an additional value of 0. The values between 50 and 3,000 represent time in milliseconds. Normally, the STOA and STOB inputs transition at the same time. A change in state in only one of the inputs only occurs if there is a failure in the STO safety system. When the value of the Discrepancy Timer Limit is between 50 and 3,000 a failure occurs:

- If the inputs are in different states longer than the programmed Discrepancy Timer Limit.
- If one of the inputs transitions twice in less time than the programmed Discrepancy Timer Limit.

A unit with the STO option will set the STO_Failure bit to “1” when a Discrepancy Timer Limit failure occurs. The STO_Failure bit is fully described below.

When the Discrepancy Timer Limit parameter is set to zero, the additional checks listed above are disabled.

STO Option (continued)

Status Bits

The following status bits are available on units with the STO option. They are available in the network input data. They can be used to monitor the status of the motor:

- **Drive_Is_Enabled** – This bit is set to “1” when the motor drive section of the unit is enabled. Power is available to the motor. This bit is set to “0” when the motor driver section is disabled.
- **Driver_Fault** – This bit is set to “1” to indicate a fault in the motor drive section of SV Servo unit. These faults are over-temperature fault, over-current fault, and when the STO feature is active. This bit is set to “1” if either or both of the STO inputs are inactive. Driver Faults are self clearing. This bit will reset itself once the fault condition is removed. This bit is set to “0” when the motor drive section is operating normally. The drive is disabled, and cannot be enabled while this bit is “1”. The drive can be in its enabled or disabled state while this bit is “0”. The Drive_Is_Enabled bit shows the enabled or disabled state of the motor drive section. The Drive_Is_Enabled bit is described above.
- **IN3_Active** – This bit is set to “1” when Input 3 (STOA) is in its active state. This bit is set to “0” when Input 3 is in its inactive state.
- **IN4_Active** – This bit is set to “1” when Input 4 (STOB) is in its active state. This bit is set to “0” when Input 4 is in its inactive state.
- **STO_Active** – Normally ‘0’, this bit is set to ‘1’ when power is removed from the motor because one or both of Inputs 3 and 4 are inactive. This bit resets itself to ‘0’ when *both* inputs are active.
- **STO_Failure** – Normally ‘0’, this bit is set to ‘1’ when:
 - 1) Either, or both, of the STOA and STOB inputs are inactive, but the motor power stage reports that it is still active.
 - 2) A fault related to the Discrepancy Timer Limit has occurred.

If either of these faults occur, the SV Servo will attempt to disable the power stage through its programming and will refuse to accept move commands. This bit cannot be cleared by commands from the host controller. It can only be cleared by cycling power to the unit.

State Diagrams

The figure below shows how an SV Servo unit with the STO option operates when the Discrepancy Timer Limit is programmed to zero.

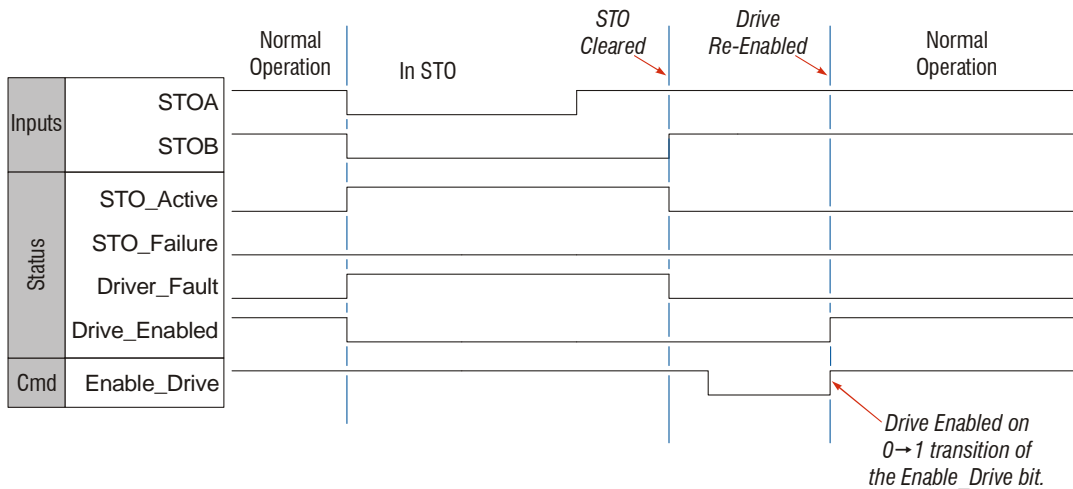

Figure R1.4 Basic STO Operation

STO Option (continued)

State Diagrams (continued)

The figure below shows how an SV Servo unit with the STO option operates when the Discrepancy Timer Limit is programmed to a value between 50 and 3,000 milliseconds.

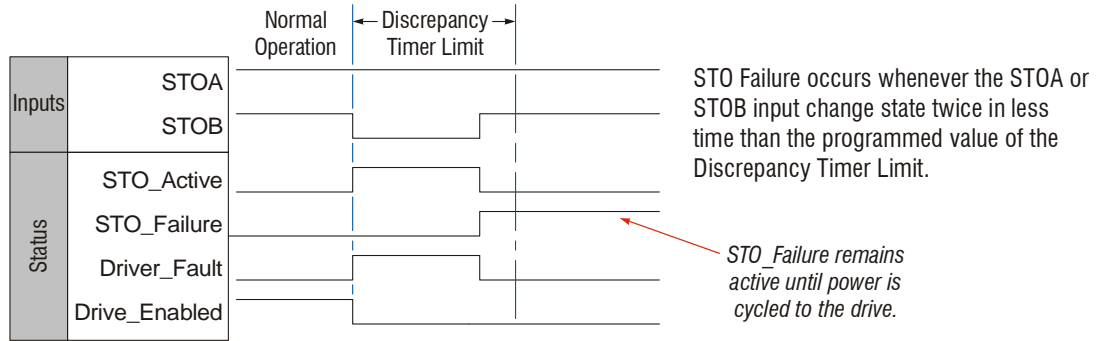
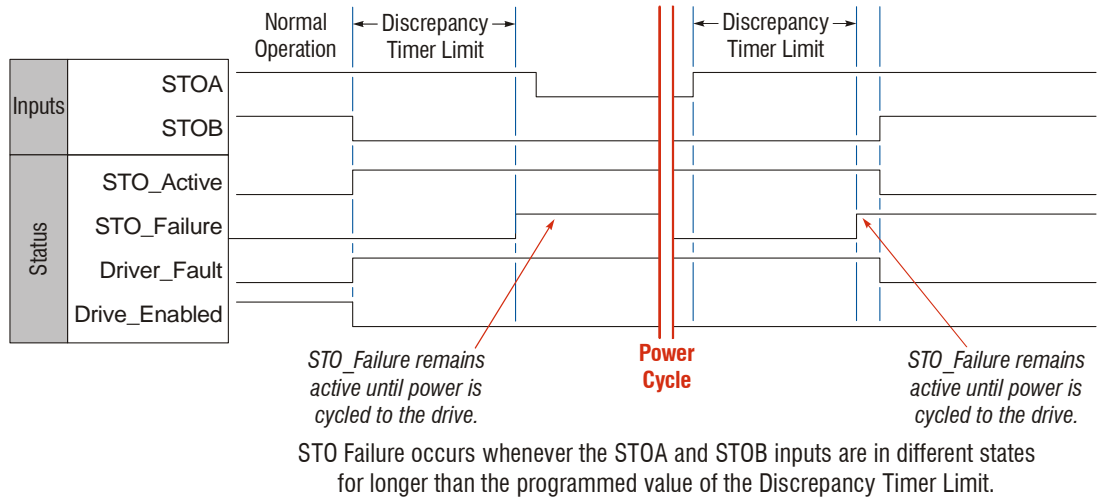

Figure R1.5 STO Operation with Discrepancy Timer Limit

Status LED's

Each SV Servo has three status LED's. As shown in figure R1.6, these LED's are located on the rear cover.

Drive Status LED

The Drive Status LED is a bi-color red/green LED. This LED shows the state of the unit as a whole.

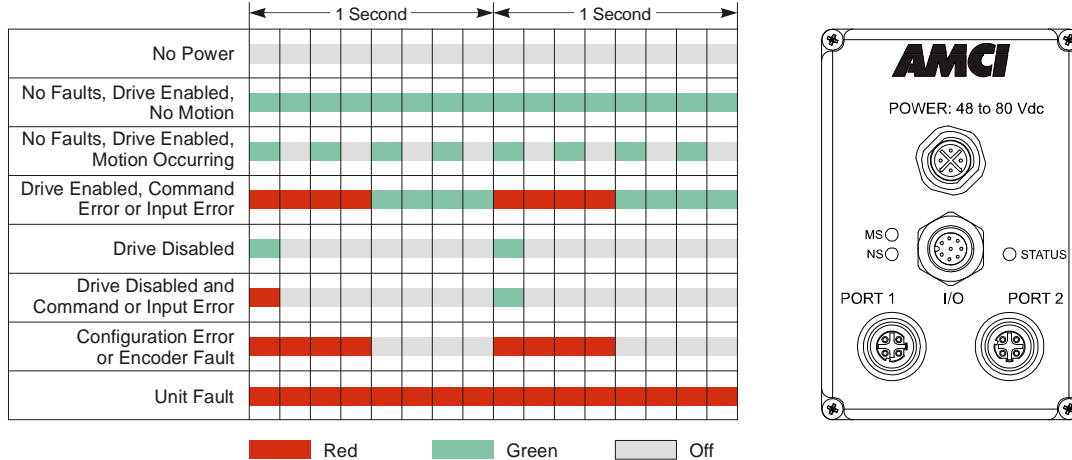

Figure R1.6 Drive Status LED States and LED Locations

Module Status (MS) LED

The Module Status LED is a bi-color red/green LED. The state of the LED depends on the state of the network adapter module.

LED State	EtherNet/IP Definition	Modbus TCP Definition	PROFINET Definition
Off	No Power	No Power	No power
Alternating Red/Green	Initializing: Power up Self-Test		
Flashing Green	Initializing: Waiting for valid physical connection to the network.		Does not occur
Steady Green	Drive and Network are operational.	Drive and Network are operational.	Device Name or IP Address are set.
Flashing Red	Initializing: IP Address conflict.		Initializing: Device Name or IP Address are not set.
	If the Network Status LED is also flashing red, the IP Address or Network Protocol has been changed. Cycle power to the unit to continue.		

Table R1.3 Module Status LED States

Status LED's (continued)

Network Status (NS) LED

The Network Status LED is a bi-color red/green LED. The state of the LED depends on the protocol the SV Servo unit is configured to.

LED State	EtherNet/IP Definition	Modbus TCP Definition	PROFINET Definition
Off	No Power	No power or no TCP connections	No power, duplicate IP address on the network, mismatch in Device Name, or no connection to IO Controller.
Alternating Red/Green	Power up Self-Test	Power up Self-Test	Power up Self-Test
Flashing Green	Ethernet connection. No Implicit CIP connections, but Explicit CIP connections may exist.	Indicates number of connections with 2 second delay between group. The SV Servo units support up to five concurrent connections.	On-line, Stop state. A connection with the IO Controller is established and it is in its STOP state.
Steady Green	Valid Ethernet network and CIP connections	Should not occur. LED should always flash when network is connected.	On-line, Run state. A connection with the IO Controller is established and it is in its RUN state.
Flashing Red	If the MS LED is steady green: Network Connection Timeout	Not Implemented	Not Implemented
	If the MS LED is blinking red: IP Address or Network Protocol changed: Cycle power		
Steady Red	Duplicate IP address on network.		Not Implemented.

Table R1.4 Network Status LED States

SV Servo Connectors

Ethernet Connectors

Figure R1.7 shows the placement of the connectors on an SV Servo unit. Figure R1.8 shows the pinout of the Ethernet connectors when viewed from the back of the device. Each Ethernet port is an “auto-sense” port that will automatically switch between 10baseT and 100baseT depending on the network equipment it is attached to. Both ports also have the auto MDI-X capability. This means that a standard cable can be used when connecting an SV Servo unit to any device, including a personal computer.

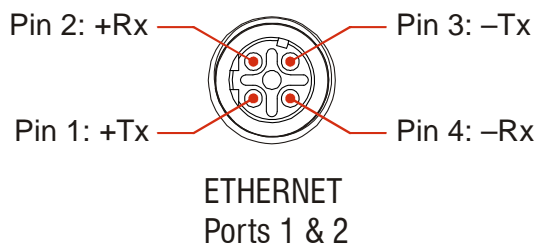

Figure R1.8 Ethernet Connector Pinout

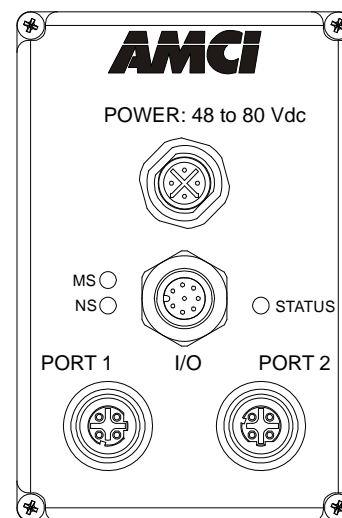

Figure R1.7 SV Servo Connector Locations

The connector is a standard four pin D-coded female M12 connector that is rated to IP67 when the mate is properly installed. Note that the orientation of the key differs between the two ports.

SV Servo Connectors (continued)

Digital Inputs Connector

All digital inputs are located on the Digital Inputs Connector. This connector is a standard eight pin A-coded M12 connector that is rated to IP67 when the mate is properly installed. Figure R1.9 shows the pinout of the connector when viewed from the back of the SV Servo unit.

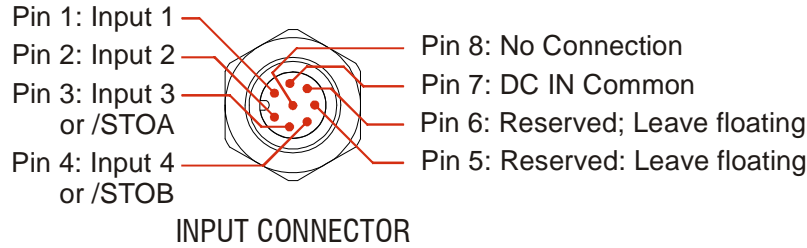

Figure R1.9 M12 Input Connector

All four digital inputs are single ended, sinking inputs that share a common DC reference. (Pin 7, DC IN Common) All of the inputs accept a nominal 12 Vdc to 24 Vdc signal without the need of a current limiting resistor. Additional information on how the digital inputs can be used can be found in the *Available Discrete Inputs* section of the chapter, starting on page 17.

When ordering an SV Servo with the STO option, the two STO inputs are also single ended. They also use the DC IN Common pin as their reference. The additional circuitry that is added with the STO option leaves the two inputs wire AND’ed to the power stage of the motor. A 12 to 24 Vdc source must be connected to both of the STO inputs for normal operation. The power stage to the motor is directly disabled if either of the inputs are pulled low or are left open circuit, which is the basic function of the Safe Torque Off feature.

Power Connector

Figure R1.10 shows the pinout of the power connector when viewed from the back of the SV Servo unit. This connector is a standard four pin S-coded M12 connector.

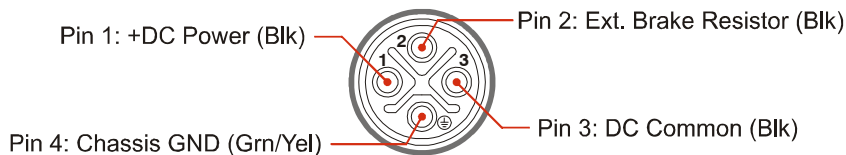
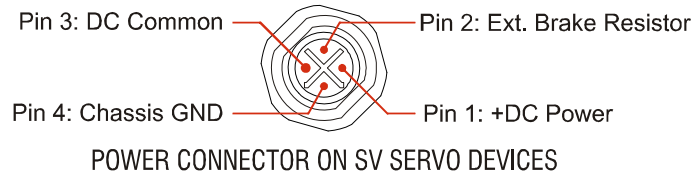

Figure R1.10 M12 Power Connector

+DC Power and DC Common are used to power the SV Servo unit. The Ext. Brake Resistor pin is for an external braking resistor that is used to dissipate regeneration energy during deceleration. The Chassis GND pin should be used to ground the chassis of the motor if it is not grounded through its mounting.

NOTE Each SV Servo can be run at voltages as high as 80 Vdc, and uses an S-coded connector because of this high voltage. Most S-coded cordsets have three black wires and a single green/yellow wire. When using such a cable with an SV Servo unit, it is strongly recommended to label the wires by pin number before installing the cordset.

SV Servo Connectors (continued)

Brake Connector

Figure R1.11 shows the brake connector pinout when viewed from the top of an SV Servo unit that was ordered with the brake option. The connector is a male, two pin, A-coded, M12 connector that is IP67 rated when its mate is properly installed.



Figure R1.11 M12 Brake Connector Pinout

Twenty-four volt power must be applied to the brake inputs in order to release the brake. A system power failure will engage the brake.

Torque Curves

SV160E2 Torque Curve Supply Voltage: 48Vdc

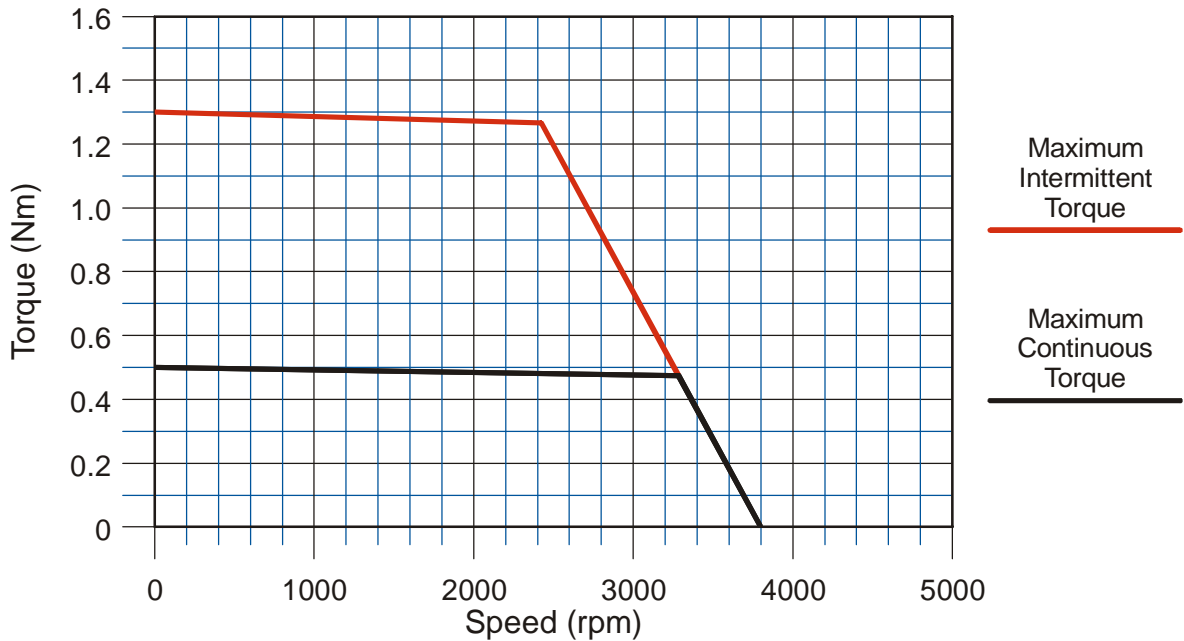

Figure R1.12 SV160E2 Torque Curves

Torque Curves (continued)

SV400E2 Torque Curve
Supply Voltage: 48Vdc

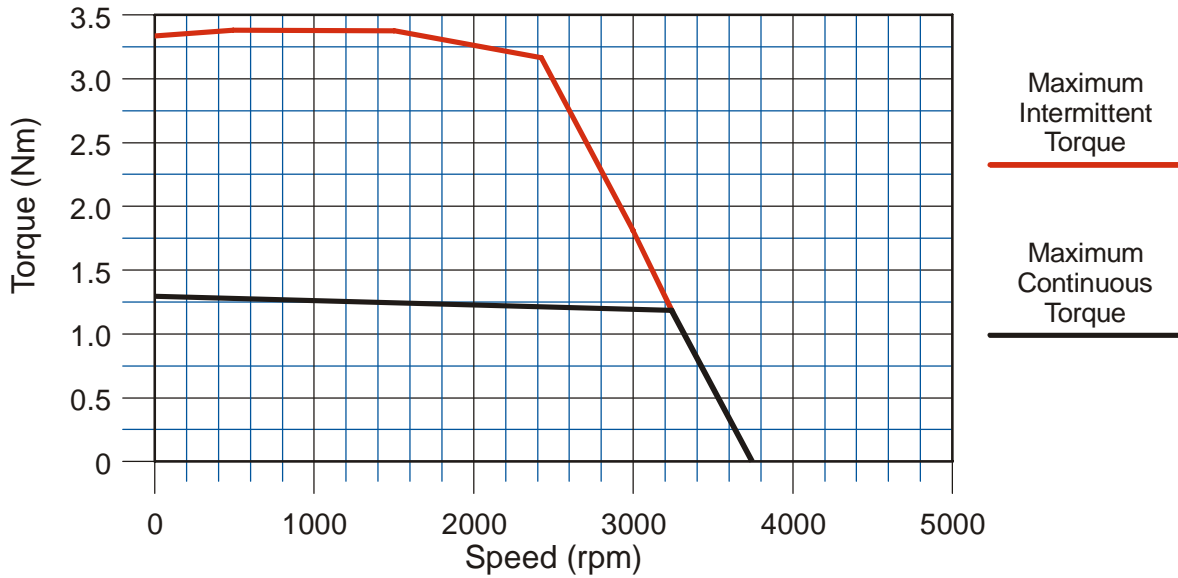

Figure R1.13 SV400E2 Torque Curves

Power Supply Sizing

The power supply should be sized base on the peak current the SV Servo unit motor can draw during a move. This value depends on your application requirements, such as the maximum motor speed and maximum motor load, as well as the DC voltage supplied to the unit. The maximum current can be limited through the Peak Torque Limit parameter.

Table R1.5 below lists the typical DC supply current that an SV Servo unit will draw when powered by a +48 Vdc supply.

Unit	Motor Load (Torque)	Motor Speed	DC Supply Current
SV160E2	0.50 Nm (rated value)	3000 RPM	6.5 Amps
	1.30 Nm (peak value)	2750 RPM	13.0 Amps
SV400E2	1.28 Nm (rated value)	3000 RPM	10.2 Amps
	3.50 Nm (peak value)	2500 RPM	20.0 Amps

Table R1.5 SV Servo Maximum Current Draw

The following methods are available to decrease the power supply current draw:

- Increase the DC supply voltage
- Run at lower speeds
- Decrease the motor load
- Decrease the acceleration values to limit peak torque

Even with a properly sized supply, it is important to choose a supply with the proper over-current protection. You should choose a supply whose protection circuitry results in a constant current control. In over-current situations, the power supply becomes a constant current supply, lowering the output voltage to keep the current within limits. This protection scheme allows you to maintain control of the motor. The other over-current protection is commonly referred to as “hiccup mode”. These power supplies briefly reset if the current limit is exceeded. This results in loss of output voltage and motor control.

Regeneration (Back EMF) Effects

All motors generate electrical energy when the mechanical speed of the rotor is greater than the speed of the rotating magnetic fields set by the drive. This is known as regeneration, or back EMF. Designers of systems with a large mass moment of inertia or high deceleration rates must take regeneration effects into account when selecting power supply components.

The first line of defense against regenerative events is an appropriately sized power supply. The additional capacitance typically found in a larger supplies can be used to absorb the regenerative energy. If your application has high deceleration rates, then a supply that can deliver 175% of peak motor power should be used.

The second line of defense is a braking resistor, also known as a regeneration resistor. Braking resistors are not included in the SV Servo products because of the limited ability to dissipate the heat generated by the resistor. An external braking resistor and its control circuitry can be added to the system. The power switch in the SV160E2 units can conduct a maximum of 10 amps. The power switch in the SV400E2 units can conduct a maximum of 15 amps. The braking resistor circuit current must be below the appropriate value.

The *Braking Resistor Calculations* section, which starts on page 81, lists the steps needed to choose a properly sized braking resistor for your application.

⚠ CAUTION Regeneration events can raise the Vdc supply voltage to an unexpected value. Components not rated for this voltage may be damaged.

- Only use power supplies that will not be damaged by regeneration events.
- Use a braking resistor if necessary.

Compatible Connectors and Cordsets

Many different connectors and cordsets are available on the market, all of which will work with the SV Servo products provided that the manufacturer follows the connector and Ethernet standards. AMCI has reviewed the following connectors and ethernet cordsets for compatibility with the SV Servo products.

Ethernet Connector

AMCI #	Binder #	Description
MS-28	99-3729-810-04	Mating connector for Ethernet Connector. Male, 4 pin D-coded. Screw terminal connections. 6 to 8 mm dia. cable. Straight, IP67 rated when properly installed.

Table R1.6 Ethernet Connectors

Input Connector

AMCI #	Binder #	Description
MS-37	99-0486-12-08	Mating connector for Input Connector. Female, 8 pin A-coded. Screw terminal connections. 6 to 8 mm dia. cable. Straight, IP67 rated when properly installed.

Table R1.7 Compatible Connectors

Power Connector

AMCI #	Binder #	Description
MS-41	99-0690-58-04	Mating connector for Power Connector. Female, 4 pin S-coded. Screw terminal connections. 16AWG conductor, 8 to 10 mm dia. cable. Right-angle, IP67 rated when properly installed.

Table R1.8 Compatible Connectors

Compatible Connectors and Cordsets (continued)

Brake Connector

Binder #	Description
99-0430-27-04	Female, 3 pin A-coded. Screw terminal connections. 0.75 mm ² (18 AWG) maximum wire size. 4 to 6 mm (0.185" to 0.236") dia. cable. Right angle, IP67 rated when properly installed.

Table R1.9 Compatible Brake Connector

Ethernet Cordset

AMCI Part #	Description
CNER-5M	4-position, 24 AWG, shielded. EIA/TIA 568B color coded. Connectors: Straight M12, D-coded, Male to RJ45. Shield attached to both connectors. Cable length: 5 m

Table R1.10 Ethernet Cordset

Input Cordset

AMCI Part #	Description
CNFL-5M	8-position, 24 AWG. Connector: Straight M12, A-coded, Female to 2 inch flying leads, 0.28" stripped. Cable length: 5 m

Table R1.11 Power Cordsets

Power Cordset

AMCI Part #	Description
CNGL-5M	4-position, 1.5 mm ² (16 AWG) Connector: Straight M12, S-coded, Female to flying leads, 0.28" stripped. Cable diameter: 0.35" Cable length: 5 m

Table R1.12 Power Cordset

Brake Cordset

AMCI #	Description
CNKL-2M	3-position, 0.34 mm ² (22 AWG) wire. Connector: Right angle M12, A-coded, Female to flying leads, 0.28" stripped. Cable length: 2 m (6.5 feet)
CNKL-5M	3-position, 0.34 mm ² (22 AWG) wire. Connector: Right angle M12, A-coded, Female to flying leads, 0.28" stripped. Cable length: 5 m (16.4 feet)

Table R1.13 Brake Cordsets

REFERENCE 2

MOTION CONTROL

When a move command is sent to an SV Servo unit, the device calculates the entire profile before starting the move or issuing an error message. This chapter explains how the profiles are calculated and the different available moves.

Definitions

Units of Measure

Distance: Every distance is measured in steps. The SV Servo uses a value of 16,384 steps per turn.

Speed: All speeds are measured in steps/second. A speed of 16,384 steps/second will result in the shaft rotating at 1 revolution/second.

Acceleration: The typical unit of measure for acceleration and deceleration is steps/second/second, or steps/second². However, when programming an SV Servo, all acceleration and deceleration values must be programmed in the unit of measure of steps/second/millisecond.

- To convert from steps/second² to steps/second/millisecond, divide the value by 1000. This must be done when converting from a value used in the equations to a value programmed into an SV Servo.
- To convert from steps/second/millisecond to steps/second², multiply the value by 1000. This must be done when converting from the value programmed into an SV Servo to the value used in the equations.

Acceleration Type: The SV Servo uses constant acceleration and deceleration during moves. This limits the time spent accelerating and decelerating during moves.

Profile Position

Profile Position is defined in counts, and represents the ideal position of the motor shaft at a particular point in time. The range of position values is -1,073,741,824 to +1,073,741,823.

Encoder Position

Encoder Position is defined in counts, and is the actual, physical position of the motor shaft. The allowable error between the Profile Position and Encoder Position values is programmable as the Maximum Position Error Limit parameter. The range of encoder position values is -1,073,741,824 to +1,073,741,823.

Continuous Torque

The maximum torque delivered by the motor when it must run at a constant speed. This value is programmable with the Continuous Torque Limit parameter, which is programmed as part of the configuration data. For the SV160E2, this parameter ranges from 0.10 Nm to 0.50 Nm. For the SV400E2, this parameter ranges from 0.25 Nm to 1.28 Nm.

Peak Torque

The maximum torque delivered by the motor during times of acceleration or deceleration. This value is programmable with the Peak Torque Limit parameter, which is part of the configuration data. The parameter ranges from the value of the Continuous Torque Limit parameter to:

- 1.30 Nm for the SV160E2 products
- 3.50 Nm for the SV400E2 products

During the limited times of acceleration or deceleration, the power delivered by the motor, (which is directly proportional to the torque), can exceed its continuous power rating without damage to the motor. This additional power allows the motor to accelerate or decelerate the inertial load faster.

Definitions (continued)

Home Position

The Home Position is any position on your machine that you can sense and stop at. There are two ways to defining the Home Position. The first is using the Preset Position command to set the Profile Position and Encoder Position registers to a known value. The second method is using one of the *Find Home* commands. If you use the unit's *Find Home* commands, the motor position and encoder position registers will automatically be set to zero once the home position is reached. Defining a Home Position is completely optional. Some applications, such as those that use the SV Servo for speed control, don't require position data at all.

Count Direction

Clockwise moves will always increase the profile position and encoder position values reported back to the host. Some of the moves, such as the Jog Move, have a positive and negative command. A positive command, such as the +Jog Move command, will result in a clockwise rotation of the shaft.

Target Position

The Target Position is the position that you want the move to end at. There are two ways to define the Target Position, with relative coordinates or absolute coordinates.

Relative Coordinates

Relative coordinates define the Target Position as an offset from the present position of the motor. Most SV Servo moves use relative coordinates.

- The range of values for the Target Position when it is treated as an offset is -1,073,741,824 to +1,073,741,823 counts. Positive offsets will result in clockwise moves, while negative offsets result in counter-clockwise moves. Note that the Profile and Encoder Positions can be forced to roll over with relative moves. For example, if the Profile Position equals 100,000, a relative move of +1,073,741,823 will result in a clockwise rotation for +1,073,741,823 counts. The position will roll over and stop at -1,073,641,825.

Absolute Coordinates

Absolute coordinates treat the Target Position as an actual position on the machine. (See *Home Position* on the previous page.)

- The range of values for the Target Position when it is treated as an actual position on the machine is -1,073,741,824 to +1,073,741,823 counts. The move will be clockwise if the Target Position is greater than the Current Position and negative if the Target Position is less than the Current Position.

Immediate Stop Deceleration

In order to limit regenerative energy when decelerating a large inertial load, the SV Servo allows you to program a deceleration rate for immediate stops. If left at its default value of zero, the SV Servo stops all motion immediately. When programmed to a value between 1,500 and 15,999, the SV Servo will decelerate at a rate of 1,500,000 to 15,999,000 steps/sec². The time to decelerate depends on the speed at which the shaft is rotating when the immediate stop is initiated. The formulas for calculating stopping time can be found in the *Constant Acceleration Equations* section, starting on page 41. Immediate Stop Deceleration is applied under the following conditions:

- CW Limit activated
- CCW Limit activated
- E-Stop Input activated
- Immediate Stop command accepted from the network interface
- Network Communications is lost
- PLC switches out of run mode (cannot be sensed on all platforms)

A Simple Move

As shown in the figure below, a move from A (Current Position) to B (Target Position) consists of several parts.

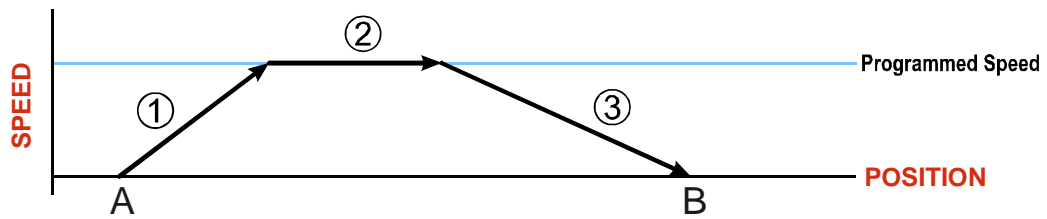

Figure R2.1 A Trapezoidal Profile

- 1) The move begins at point A, where the motor accelerates at the programmed *Acceleration Value* until the speed of the motor reaches the *Programmed Speed*. Both the *Acceleration Value* and the *Programmed Speed* are programmed when the move command is sent to the SV Servo.
- 2) The motor continues to run at the *Programmed Speed* until it reaches the point where it must decelerate before reaching point B at zero speed.
- 3) The motor decelerates at the *Deceleration Value*, which is also programmed by the move command, until the *Target Position (B)* is reached. The motor stops at this point. Note that the acceleration and deceleration values can be different in the move.

Figure R2.1 above shows a Trapezoidal Profile. A Trapezoidal Profile occurs when the *Programmed Speed* is reached during the move. This occurs when the number of steps needed to accelerate and decelerate are less than the total number of steps in the move.

Figure R2.2 below shows a Triangular Profile. A Triangular Profile occurs when the number of steps needed to accelerate to the *Programmed Speed* and decelerate from the *Programmed Speed* are greater than the total number of steps in the move. In this case, the profile will accelerate as far as it can before it has to decelerate to reach the *Target Position* at zero speed. The *Programmed Speed* is never reached.

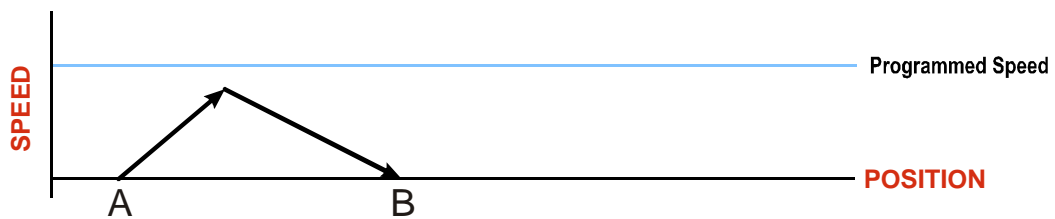

Figure R2.2 A Triangular Profile

Controlled and Immediate Stops

Once a move is started, there are several ways to stop the move before it comes to an end. These stops are broken down into two types:

- **Controlled Stop:** The axis immediately begins decelerating at the move's programmed deceleration value until it reaches zero speed. The motor position value is still considered valid after a Controlled Stop.
- **Immediate Stop:** The *Immediate Stop Deceleration* parameter, described on page 30, is used to decelerate the load. If the Immediate Stop Deceleration parameter is set to zero, the move stops immediately, without deceleration. If the position error during the stop does not exceed the Maximum Position Error Limit value, the motor will stop at the Profile Position value. If the position error during the stop exceeds the Maximum Position Error Limit value, the SV Servo will disable the motor and issue a Position_Invalid fault.

Host Control

Hold Move Command: This command can be used with some moves to bring the axis to a Controlled Stop. The move can be resumed and finished, or it can be aborted. Not all moves are affected by this command. The section *Basic Move Types*, starting on page 33, describes each move type in detail, including if the move is affected by this command.

Immediate Stop Command: The *Immediate Stop Deceleration* parameter, described on page 30, is used to decelerate the load. If the Immediate Stop Deceleration parameter is set to zero, the move stops immediately, without deceleration. If a stall is not detected during the stop, the motor will return to the Profile Position value. If a stall is detected during the stop, the SV Servo will disable the motor and issue a Position_Invalid fault. See *Stall Detection* on page 17 for a description of the stall detection process.

Hardware Control

Stop Jog or Registration Move Input: Triggering this input type during a Jog Move or Registration Move will bring the move to a controlled stop. The controlled stop is triggered on an inactive-to-active state change on the input. Only Jog Moves and Registration Moves can be stopped this way, all other moves ignore this input.

CW Limit and CCW Limit Inputs: In most cases, activating these inputs during a move will bring the axis to an Immediate Stop. The *Immediate Stop Deceleration* parameter, described on page 30, is used to decelerate the load. The exceptions are the *CW/CCW Find Home* commands, the *CW/CCW Jog Move* commands, and the *CW/CCW Registration Move* commands. The *Find Home* commands are explained in the reference section, *Homing an SV Servo Controller*, which starts on page 45. The *CW/CCW Jog Move* commands are fully explained on page 35, and the *CW/CCW Registration Move* commands are fully explained on page 36.

Emergency Stop Input: It is possible to configure an input as an Emergency Stop Input. When an Emergency Stop Input is activated, the axis will come to an Immediate Stop. The move cannot be restarted. The *Immediate Stop Deceleration* parameter, described on page 30, is used to decelerate the load. If a stall is not detected during the stop, the motor will return to the Profile Position value. If a stall is detected during the stop, the SV Servo unit will disable the motor and issue a Position_Invalid fault. See *Stall Detection* on page 17 for a description of the stall detection process.

Basic Move Types

Relative Move

Relative Moves move an offset number of steps (n) from the current Profile Position (A). A trapezoidal profile is shown to the right, but Relative Moves can also generate triangular profiles. The command's Target Position is the move's offset. The offset can be in the range of $-1,073,741,824$ to $+1,073,741,823$ counts. Positive offsets will result in clockwise moves, while negative offsets result in counter-clockwise moves.

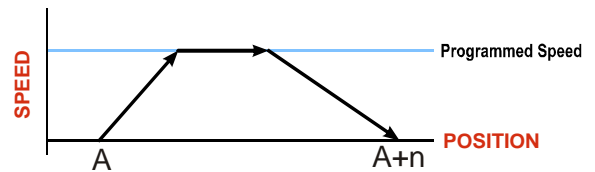

Figure R2.3 Relative Move



NOTE Relative Moves allow you to move your machine without having to calculate absolute positions. If you are indexing a rotary table, you can preform a relative move of 30° multiple times without recalculating new target positions in your controller. If you perform the same action with Absolute Moves, you would have to calculate your 30° position followed by your 60° position, followed by your 90° position, etc.

Relative Moves can be brought to a Controlled Stop by using the Hold Move Command from your host controller. When the command is accepted, the axis will immediately decelerate at the programmed rate and stop. When stopped successfully, the SV Servo will set a *In_Hold_State* bit in the input data table. The Relative Move can be restarted with the Resume Move command from the host controller or the move can be aborted by starting another move. The Resume Move command allows you to change the move's Programmed Speed, Acceleration Value, and Deceleration Value. The Target Position cannot be changed with the Resume Move Command.

Controlled Stops

- The move completes without error.
- You issue a Hold Move command through the Network Output Data. Note that your holding position will most likely not be the final position you commanded. You can resume a held Relative Move by using the Resume Move command or the move can be aborted by starting another move. The use of the Hold Move and Resume Move commands is further explained in the *Controlling Moves In Progress* section starting on page 40.

Immediate Stops

- You issue an Immediate Stop command through the Network Output Data.
- An inactive-to-active transition on an input configured as an E-Stop Input. A *Reset Errors* command must be issued before moves are allowed again.
- A CW or CWW Limit Switch is reached. A *Reset Errors* command must be issued before moves are allowed again.
- If set to a non-zero value, the *Immediate Stop Deceleration* parameter, described on page 30, is used to decelerate the load.

Basic Move Types (continued)

Absolute Move

Absolute Moves move from the current Profile Position (A) to a given position (B). (The SV Servo calculates the direction and number of steps needed to move to the given position and moves that number of steps.) A trapezoidal profile is shown to the right, but Absolute Moves can also generate triangular profiles. The command's Target Position can be in the range of -1,073,741,824 to +1,073,741,823 counts. The move will be clockwise if the Target Position is greater than the Current Position and counter-clockwise if the Target Position is less than the Current Position.

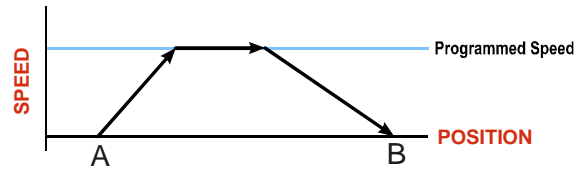

Figure R2.4 Absolute Move

NOTE Absolute Moves allow you to move your machine without having to calculate relative positions. If you are controlling a rotary table, you can drive the table to any angle without having to calculate the distance to travel. For example an Absolute Move to 180° will move the table to the correct position regardless of where the move starts from.

Controlled Stops

- The move completes without error.
- You issue a Hold Move command through the Network Output Data. Note that your holding position will most likely not be the final position you commanded. You can resume a held Absolute Move by using the Resume Move command or the move can be aborted by starting another move. The use of the Hold Move and Resume Move commands is further explained in the *Controlling Moves In Progress* section starting on page 40.

Immediate Stops

- You issue an Immediate Stop command through the Network Output Data.
- An inactive-to-active transition on an input configured as an E-Stop Input. A *Reset Errors* command must be issued before moves are allowed again.
- A CW or CWW Limit Switch is reached. A *Reset Errors* command must be issued before moves are allowed again.
- If set to a non-zero value, the *Immediate Stop Deceleration* parameter, described on page 30, is used to decelerate the load.

Basic Move Types (continued)

CW/CCW Jog Move

Jog Moves move in the programmed direction as long as the command is active. Two commands are available. The CW Jog Move will increase the Profile Position while the CCW Jog Move will decrease the Profile Position. These commands are often used to give the operator manual control over the axis.

Jog Moves are also used when you are interested in controlling the speed of the shaft instead of its position. One such application is driving a conveyor belt. To accommodate these applications, the running speed, acceleration, and deceleration of the Jog Move can be changed *while the move is in progress*.

The CW Limit and CCW Limit inputs behave differently for CW/CCW Jog Moves and CW/CCW Registration Moves than all other move types. Like all moves, activating a limit will bring the move to an Immediate Stop. Unlike other moves, a Jog or Registration move can be started when an end limit switch is active provided that the commanded direction is opposite that of the activated switch. For example, a CW Jog Move can be issued while the CCW limit switch is active. This allows you to move off of an activated end limit switch.

As shown below, a Jog Move begins and accelerates at the programmed rate to the Programmed Speed and continues until a stop condition occurs.

It is possible to change the speed of a Jog Move without stopping the motion. The Programmed Speed, Acceleration, and Deceleration parameters can be changed during a Jog Move. When the Programmed Speed is changed, the motor will accelerate or decelerate to the new Programmed Speed using the new accelerate/ decelerate parameter values.

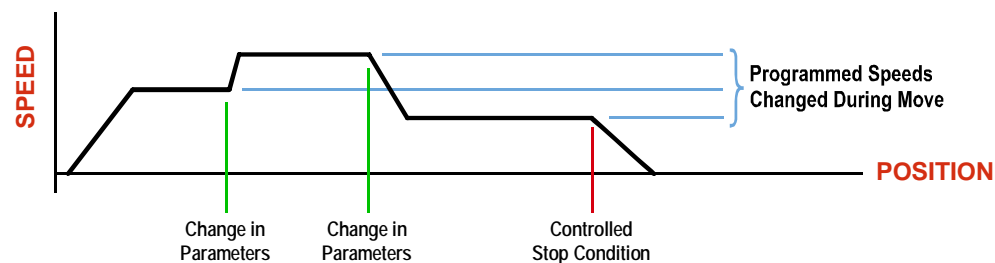

Figure R2.5 Jog Move

Controlled Stops

- The Jog Move Command bit is reset to “0”.
- An inactive-to-active transition on an input configured as a *Stop Jog or Registration Move* Input.
- You issue a Hold Move command in the Network Output Data. This brings the move to an end.

Immediate Stops

- You issue an Immediate Stop command through the Network Output Data.
- An inactive-to-active transition on an input configured as an E-Stop Input. A *Reset Errors* command must be issued before moves are allowed again.
- A CW or CCW Limit Switch is reached. A *Reset Errors* command must be issued before moves are allowed again.
- If set to a non-zero value, the *Immediate Stop Deceleration* parameter, described on page 30, is used to decelerate the load.



Note that it is possible to *start* a move while a CW or CCW Limit Switch is active as long as the direction of travel is *opposite* that of the activated Limit Switch. For example, it is possible to start a CW Jog Move while the CCW Limit Switch is active.

Basic Move Types (continued)

CW/CCW Registration Move

Similar to a Jog Move, a Registration Move will travel in the programmed direction as long as the command is active. CW Registration Moves increase the Profile Position count while the CCW Registration Moves decrease the Profile Position count. When the command terminates under Controlled Stop conditions, the SV Servo will output a programmed number of steps as part of bringing the move to a stop. Note that all position values programmed with a Registration Move are relative values, not absolute machine positions.

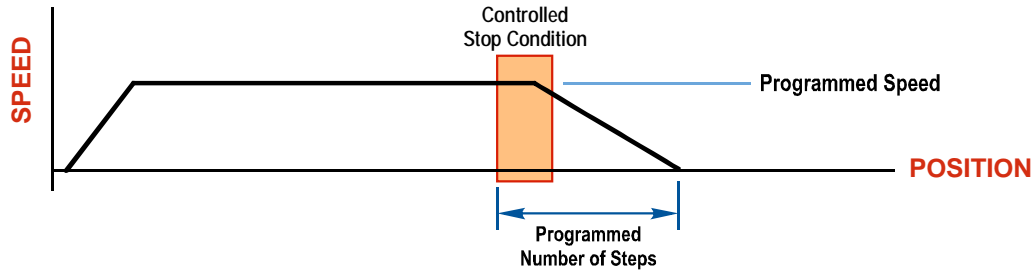

Figure R2.6 Registration Move

NOTE If the Programmed Number of Steps are less than the number of steps needed to bring the axis to a stop based on the Programmed Speed and Deceleration values sent with the command, the move will not begin and the SV Servo will issue a Command Error.

An additional feature of the Registration Moves is the ability to program the driver to ignore the Controlled Stop conditions until a minimum number of steps have occurred. This value is programmed through the Minimum Registration Move Distance parameter, which is set when you command the Registration Move. The figure below shows how the Minimum Registration Move Distance parameter affects when the Stop Condition is applied to the move. As shown in the second diagram, Controlled Stop conditions are level triggered, not edge triggered. If a Controlled Stop Condition occurs before the Minimum Registration Move Distance is reached and stays active, the move will begin its controlled stop once the Minimum Registration Move Distance is reached.

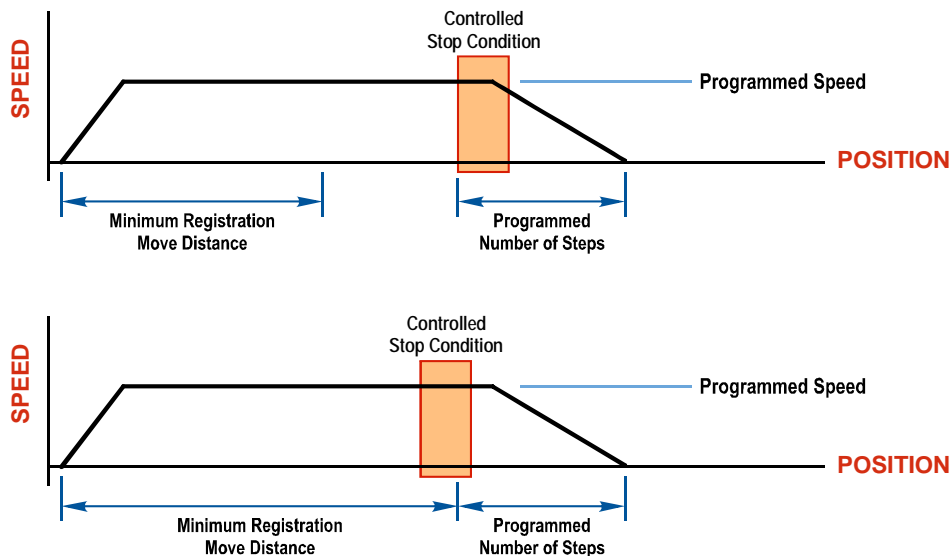

Figure R2.7 Min. Registration Move Distance

Basic Move Types (continued)**CW/CCW Registration Move (continued)****Controlled Stops**

- The Registration Move Command bit is reset to “0”.
- A positive transition on an input configured as a *Stop Jog or Registration Move* Input.

NOTE

Starting a Registration Move with a *Stop Jog or Registration Move* Input in its active state will result in a move of (*Minimum Registration Distance + Programmed Number of Steps*).

- You issue a Hold Move command through the Network Output Data. The SV Servo responds by using the programmed Deceleration value to bring the move to a stop, without using the value of the Programmed Number of Steps parameter. A Registration Move does not go into the Hold State if the Hold Move command is used to stop the move and it cannot be restarted with the Resume Move command.

Immediate Stops

- You issue an Immediate Stop command through the Network Output Data.
- An inactive-to-active transition on an input configured as an E-Stop Input. A *Reset Errors* command must be issued before moves are allowed again.
- A CW or CWW Limit Switch is reached. A *Reset Errors* command must be issued before moves are allowed again.
- If set to a non-zero value, the *Immediate Stop Deceleration* parameter, described on page 30, is used to decelerate the load.

NOTE

Note that it is possible to *start* a move while a CW or CCW Limit Switch is active as long as the direction of travel is *opposite* that of the activated Limit Switch. For example, it is possible to start a CW Registration Move while the CCW Limit Switch is active.

Indexed Moves

All of the moves that have been explained in the chapter up to this point can be started by a transition on one of the inputs instead of a command from the network. If the *Indexed Move* bit is set when the command is issued, the SV Servo will not run the move until the configured input makes an inactive-to-active transition. This allows you to run time critical moves that cannot be reliably started from the network due to messaging time delays.

- ▶ The input must be configured as a *Start Indexed Move Input*.
- ▶ The move begins with an inactive-to-active transition on the input. Note that an active-to-inactive transition on the input will not stop the move.
- ▶ The move command must stay in the Network Output Data while performing an Indexed Move. The move will not occur if you reset the command word before the input triggers the move.
- ▶ The move can be run multiple times. (The Command Bit for the move does not have to toggle between moves.) Command data can be changed. For Jog and Registration Moves, the changes take effect immediately. For all other moves, the changes are applied on the next move. The move is run on every inactive-to-active transition on the physical input if a move is not currently in progress. Once a move is triggered, the Start Indexed Move Input is ignored by the SV Servo until the triggered move is finished.
- ▶ A Jog Move that is started as an Indexed Move will come to a controlled stop when the command bit in the Network Output Data is reset to zero.
- ▶ It is possible to perform an indexed Jog Move by configuring two inputs for their respective functions. The first input, configured as a *Start Indexed Move Input*, starts the jog and the second, configured as a *Stop Jog or Registration Move Input* causes the jog to end.
- ▶ It is possible to perform an indexed Registration Move by configuring two inputs for their respective functions. The first input, configured as a *Start Indexed Move Input*, starts the move and the second, configured as a *Stop Jog or Registration Move Input* causes the registration function to occur.
- ▶ You cannot issue a Hold Command with the Indexed Bit set and have the Hold Command trigger on the inactive-to-active transition of a physical input. Hold Commands are always acted upon as soon as they are accepted from the Network Output Data.
- ▶ You cannot issue an Immediate Stop Command with the Indexed Bit set and have the Immediate Stop Command trigger on the inactive-to-active transition of a physical input. Immediate Stop Commands are always acted upon as soon as they are accepted from the Network Output Data. If you need this functionality, consider programming the physical input as an E-Stop Input.
- ▶ You cannot issue a Clear Error Command with the Indexed Bit set and have the Clear Error Command trigger on the inactive-to-active transition of a physical input. Clear Error Commands are always acted upon as soon as they are accepted from the Network Output Data.

Axis Follower Moves

On controllers that support motion axis programming, such as the Rockwell Automation ControlLogix platforms, the SV Servo can be tied to the motion axis, with the host controller periodically sending position and velocity data to the unit as part of the axis update. The loop is closed by the SV Servo by controlling the position and velocity of the motor. Both linear and circular axes are supported.

When compared with Linear Axis Follower Moves, Circular Axis Follower Moves have one additional parameter. This parameter is often called the “Position Unwind” value, and it defines the point at which the position rolls over and returns to zero. On the SV Servo units, this parameter has a range of 1,024 to 1,073,741,824.

NOTE  When using the SV Servo as an axis follower, it is best to run the virtual axis as a high priority event driven periodic task.

NOTE  Be aware of the potential for position overflow in systems that use linear axis follower. One example is a conveyor that always rotates in one direction. If the position value overflows, it will switch from the maximum positive value to the maximum negative value, or vice versa, and unpredictable motion may occur.

A sample program that demonstrates virtual axis programming on the ControlLogix platform is available on the AMCI website at <https://www.amci.com/industrial-automation-support/sample-programs/>. If you are using a different host controller that supports motion axis programming, feel free to contact AMCI technical support for assistance in programming your controller.

Controlling Moves In Progress

Each SV Servo has the ability to place a running move on hold and later resume the move if an error did not occur while the move was in its Hold state. One potential application for this feature is bringing a move to a controlled stop when your controller senses an end-of-stock condition. The move can be put in its Hold state until the stock is replenished and then the move can be resumed.

Note that you do not have to resume a move once it has been placed in its Hold state. You can place a move in its Hold state to prematurely end the move with a controlled stop and issue a new move of any type from the stopped position.

The figure below shows a profile of a move that is placed in its Hold state and later resumed.

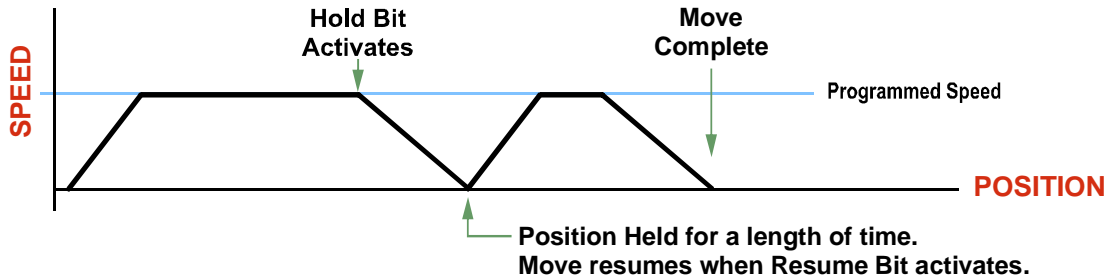

Figure R2.8 Hold/Resume a Move Profile

Jog Moves

Jog Moves can be brought to a controlled stop by issuing a Hold Move command, but they cannot be restarted.

Registration Moves

Registration Moves can be brought to a controlled stop by issuing a Hold Move command, but they cannot be restarted.

Absolute and Relative Moves

Absolute and Relative Moves can be placed in a Hold state and resumed if error conditions, such as programming errors, have not occurred. New Acceleration, Deceleration, and Programmed Speed parameters can be written to the SV Servo while these moves are in their hold states. If the parameters are accepted without error, the move can be resumed and it will use the new parameter values. Note that a change to the Target Position is ignored.

Disabling the Motor

It is possible to disable the motor while a move is in progress. If this occurs, the SV Servo uses the move's programmed deceleration rate to bring motion to a stop before removing power from the motor. The SV Servo also issues a command error when the motor is disabled during a move.

REFERENCE 3

MOVE PROFILE CALCULATIONS

This reference was added because some of our customers must program very precise profiles. Understanding this section is not necessary before programming the SV Servo and it can be considered optional.

The equations in this reference use a unit of measure of steps/second/second (steps/second^2) for acceleration and deceleration. However, when programming the SV Servo, all acceleration and deceleration values must be programmed in the unit of measure of steps/second/millisecond.

- To convert from steps/second^2 to $\text{steps/second/millisecond}$, divide the value by 1000. This must be done when converting from a value used in the equations to a value programmed into the SV Servo.
- To convert from $\text{steps/second/millisecond}$ to steps/second^2 , multiply the value by 1000. This must be done when converting from the value programmed into the SV Servo to the value used in the equations.

Constant Acceleration Equations

With constant acceleration moves, the speed of the move will increase linearly towards the Programmed Speed. This is the fastest form of acceleration, resulting in the fastest move between two points at its programmed speed.

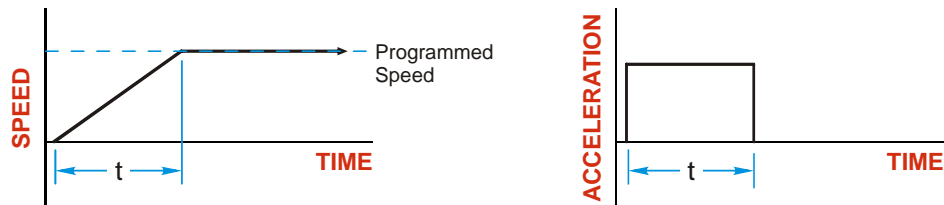
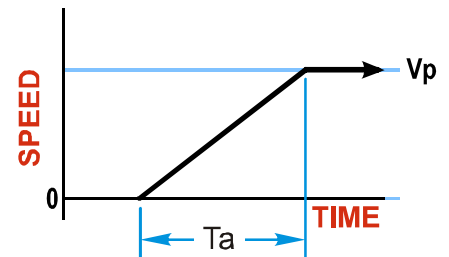

Figure R3.1 Constant Acceleration Curves

Variable Definitions

The following variables are used in these equations:

- V_P = Programmed Speed of the move
- a = Acceleration value. Must be in the units of steps/second^2
- d = Deceleration value. Must be in the units of steps/second^2
- T_A or T_D = Time needed to complete the acceleration or deceleration phase of the move
- D_A or D_D = Number of Steps needed to complete the acceleration or deceleration phase of the move



Constant Acceleration Equations (continued)

Figure R3.1 gives the equations to calculate time and distance needed for acceleration during a move.

Acceleration Type	T _A or T _D (Time to Accelerate or Decelerate)	D _A or D _D (Distance to Accelerate or Decelerate)
Linear	$T_A = V_P/a$	$D_A = T_A * V_P/2$

Table R3.1 Acceleration Equations

If the sum of the D_A and D_D values of the move is *less than* the total number of steps in the move, your move will have a Trapezoidal profile.

If the sum of the D_A and D_D values of the move is *equal to* the total number of steps in the move, your move will have a Triangular profile and your move will reach the Programmed Speed before it begins to decelerate.

If the sum of the D_A and D_D values of the move is *greater than* the total number of steps in the move, your move will have a Triangular profile and it *will not* reach the Programmed Speed before it begins to decelerate.

As an example, lets assume the values in table R3.2 for a move profile.

Name	Value	SV Servo Parameter Values
Acceleration (a)	20,000 steps/sec ²	20
Deceleration (d)	25,000 steps/sec ²	25
Programmed Speed (V _P)	100,000 steps/sec	100,000

Table R3.2 Sample Values

From figure R3.1:

Time to accelerate: $T_A = V_P/a = 100,000/20,000 = 5.000$ seconds

Time to decelerate: $T_D = V_P/d = 100,000/25,000 = 4.000$ seconds

Distance to Accelerate: $D_A = T_A * V_P/2 = 5.000 * 100,000/2 = 250,000$ steps

Distance to Decelerate: $D_D = T_D * V_P/2 = 4.000 * 100,000/2 = 200,000$ steps

Total Distance needed to accelerate and decelerate: $250,000 + 200,000 = 450,000$ steps

If a move with the above acceleration, deceleration, and programmed speed has a length greater than 450,000 steps, the SV Servo will generate a Trapezoidal profile. If the move is equal to 450,000 steps, the SV Servo will generate a Triangular profile and the unit will travel at the programmed speed for one count. If the move is less than 450,000 steps, the SV Servo will generate a Triangular profile and the programmed speed will not be reached.

In the case of a Triangular profile where the programmed speed is not reached, it is fairly easy to calculate the maximum speed (V_M) attained during the move. Because the move is always accelerating or decelerating, the total distance traveled is equal to the sum of D_A and D_D.

$D_A = T_A * V_M/2$ and $T_A = V_M/a$. By substitution:

$D_A = V_M/a * V_M/2 = V_M^2/2a$. By the same method,

$D_D = V_M^2/2d$.

Therefore, total distance traveled =

$D_A + D_D = V_M^2/2a + V_M^2/2d$.

In the case where the acceleration and deceleration values are equal, this formula reduces to:

$D_A + D_D = V_M^2/a$

Constant Acceleration Equations (continued)

Continuing the example from table R3.2, assume a total travel distance of 300,000 steps.

$$D_A + D_D = \frac{V_M^2}{2a} + \frac{V_M^2}{2d}$$

$$300,000 \text{ steps} = \frac{V_M^2}{2(20,000)} + \frac{V_M^2}{2(25,000)}$$

$$300,000 \text{ steps} = \frac{V_M^2}{40,000} + \frac{V_M^2}{50,000}$$

$$300,000 \text{ steps} = \frac{5}{5} \left(\frac{V_M^2}{40,000} \right) + \frac{4}{4} \left(\frac{V_M^2}{50,000} \right)$$

$$300,000 \text{ steps} = \frac{5V_M^2}{200,000} + \frac{4V_M^2}{200,000}$$

$$300,000 (200,000) = 9V_M^2$$

$$\frac{60,000 \times 10^6}{9} = V_M^2$$

$$V_M = 81,650 \text{ steps/sec}$$

Once you have calculated the maximum speed, you can substitute this value into the time and distance formulas in table R3.1 to calculate time spent and distance traveled while accelerating and decelerating.

Total Time Equations

For Trapezoidal Profiles you must first determine the number of counts that you are running at the Programmed Speed. This value, (D_P below), is equal to your D_A and D_D values subtracted from your total travel. You can then calculate your total profile time, (T_T below), from the second equation.

$$D_P = (\text{Total Number of Steps}) - (D_A + D_D)$$

$$T_T = T_A + T_D + D_P/V_P$$

For Triangular Profiles, the total time of travel is simply:

$$T_T = T_A + T_D$$

Notes

HOMING AN SV SERVO CONTROLLER

This chapter explains the various ways of homing an SV Servo. Inputs used to home the unit are introduced and diagrams that show how the unit responds to a homing command are given.

Definition of Home Position

The Home Position is any position on your machine that you can sense and stop at. Once at the Home Position, the Profile Position must be set to an appropriate value. If you use the unit's *CW/CCW Find Home* commands, the Profile Position will automatically be set to zero once the home position is reached. *When the Profile Position is preset or homed, the Encoder Position will also be set to the same value.*

NOTE  Defining a Home Position is completely optional. Some applications, such as those that use an SV Servo for speed control, don't require position data at all.

Definition of Homing Speed

Homing speed is the speed of the final segment of the homing move. It is equal to 10% of the Target Speed that is programmed as part of the move.

Position Preset

One of the ways to define the Home Position is to issue the Preset Position command over the network. The Profile and Encoder Position values can be preset to any value in the range of -1,073,741,824 to +1,073,741,823.

CW/CCW Find Home Commands

The other choice is to use the unit's Find Home commands to order the SV Servo to find the Home Position based on sensors brought into the unit. The CW Find Home command begins searching by rotating the motor shaft in the clockwise direction and ends when the home sensor triggers while the SV Servo is rotating in the clockwise direction *at the Homing Speed*. The CCW Find Home command operates in the same way but starts and ends with motion in the counter-clockwise direction.

Homing Inputs

Up to three physical DC inputs can be used when homing the driver.

- **Home Input:** This input is used to define the actual home position of the machine.
- **CW Limit Switch Input:** This input is used to prevent overtravel in the clockwise direction.
- **CCW Limit Switch Input:** This input is used to prevent overtravel in the counter-clockwise direction.

Homing Configurations

A SV Servo must have one of its DC inputs configured as the home input before one of the *CW/CCW Find Home* commands can be issued.

NOTE  You do not have to configure and use CW or CCW Limits. If you choose to configure the device this way, then the SV Servo has no way to automatically prevent over travel during a homing operation. In linear applications, you must prevent over travel by some external means, or ensure that the homing command is issued in the direction that will result in reaching the homing input directly.

Homing Profiles

NOTE  The CW Find Home command is used in all of these examples. The CCW Find Home command will generate the same profiles in the opposite direction.

Home Input Only Profile

Figure R4.1 below shows the move profile generated by a CW Find Home command when it finds the Home Input without first encountering an end limit switch.

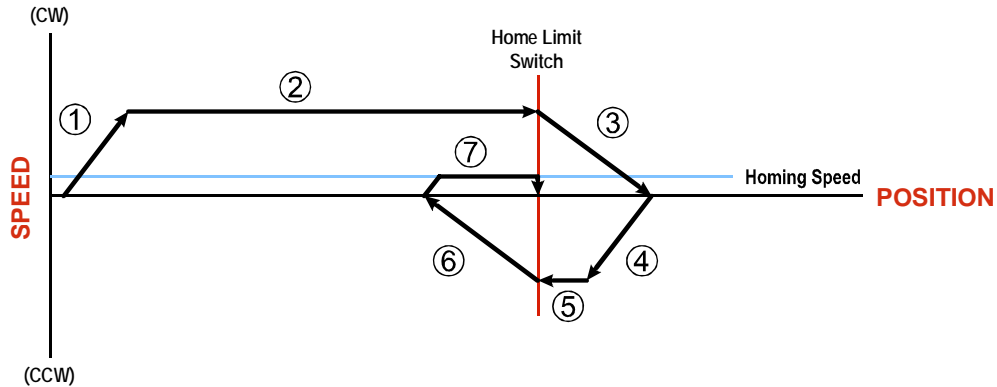



Figure R4.1 Home Input Profile

- 1) Acceleration to the Programmed Speed
- 2) Run at the Programmed Speed until the Home Input activates
- 3) Deceleration and stop, followed by a two second delay.
- 4) Acceleration to the Programmed Speed opposite to the requested direction.
- 5) Run opposite the requested direction until the Home Input transitions from Active to Inactive
- 6) Deceleration and stop, followed by a two second delay.
- 7) Return to the Home Input at the Homing Speed. (10% of the Programmed Speed.) Stop when the Home Input transitions from inactive to active.

NOTE  If the Home Input is active when the command is issued, the move profile begins at step 5 above.

Homing Profiles (continued)

Profile with Overtravel Limit

Figure R4.2 below shows the move profile generated by a CW Find Home command when you use the CW Overtravel Limit.

The profile is generated when you encounter an overtravel limit in the direction of travel. (In this example, hitting the CW limit while traveling in the CW direction.)

NOTE The SV Servo will stop and issue an *Input Error* to your host if you activate the overtravel limit associated with travel in the opposite direction. i.e. Activating the CCW limit during a CW Find Home command. This can occur if the overtravel limits are not wired to the SV Servo correctly, or if both overtravel limits are activated while the unit is trying to find the home position.

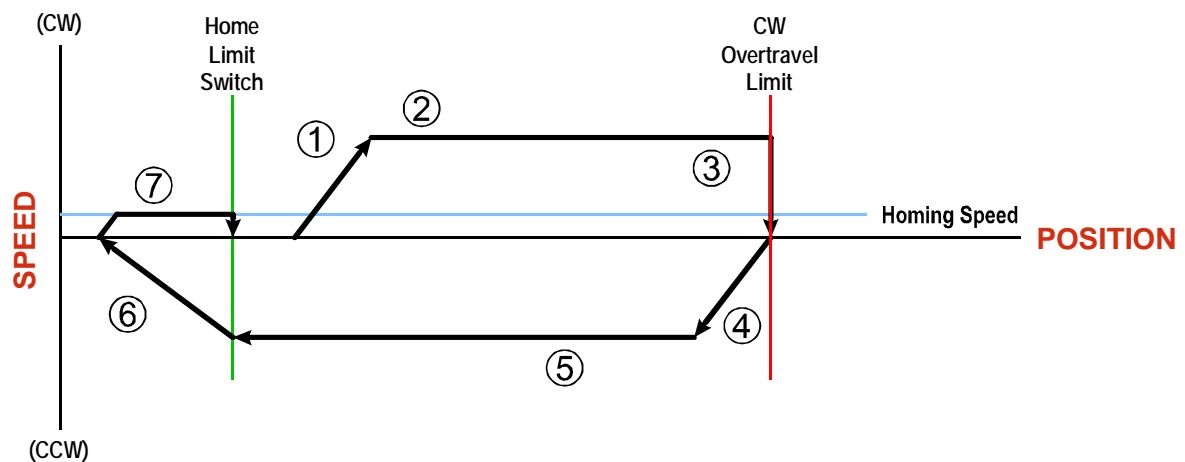

Figure R4.2 Profile with Overtravel Limit

- 1) Acceleration to the Programmed Speed
- 2) Run at the Programmed Speed
- 3) Hit CW Limit and stop, followed by a two second delay. The Immediate Stop Deceleration value is used to decelerate at this point. If this parameter equals zero, the motor stops without deceleration.
- 4) Acceleration to the Programmed Speed opposite to the requested direction.
- 5) Run opposite the requested direction until the Home Input transitions from Active to Inactive
- 6) Deceleration and stop, followed by a two second delay.
- 7) Return to the Home Input at the Homing Speed. (10% of the Programmed Speed.) Stop when the Home Input transitions from Inactive to Active.

NOTE If the overtravel limit is active when the Find Home Command is issued, the profile will begin at step 4.

Controlling Find Home Commands In Progress**Controlled Stops**

- The move completes without error.
- You issue a Hold Move command through the Network Output Data. This will abort the command and the axis will decelerate at the programmed rate until it stops. Note that Find Home commands cannot be resumed once held.

Immediate Stops

- You issue an Immediate Stop command through the Network Input Data.
- An inactive-to-active transition on an input configured as an E-Stop Input.
- The overtravel limit associated with travel in the opposite direction is activated. i.e. Activating the CCW limit during a CW Find Home command. This can occur if the overtravel limits are not wired to the SV Servo correctly, or if both overtravel limits are activated while the unit is trying to find the home position.

CONFIGURATION MODE DATA FORMAT

This chapter covers the formats of the Network Output Data used to configure the SV Servo as well as the formats of the Network Input Data that contains the responses from the device.

Modes of Operation

An SV Servo has two operating modes, Configuration Mode and Command Mode. You switch between these modes by changing the state of a single bit in the Network Output Data.



Once in Command Mode, the drive must be disabled before the SV Servo will accept new configuration data. If you send configuration data to the SV Servo while in Command Mode with the drive enabled, the unit will send a Command Error response.

Configuration Mode

Configuration Mode gives you the ability to select the proper configuration for your application without having to set any switches. Host platforms can be programmed to write configuration data to the SV Servo on power up. The ladder logic needed to configure an SV Servo is included in the sample programs available from AMCI. Host platforms that use EDS or GSDML files may give you a method to configure the SV Servo from within the host's programming software. This data is automatically written to the SV Servo when the unit connects to the network.

A valid configuration can be saved to the unit's Flash memory and the SV Servo will use this as a default configuration on every power up. If you use this method, you can still write down a new configuration to the unit at any time. The new configuration is stored in RAM and is lost on power down unless you issue a command to store the new configuration in flash. EDS and GSDML configurations are automatically written to RAM when the SV Servo connects to the network. If a configuration error exists on power up, the SV Servo will switch to configuration mode and show the first parameter with an error.

Command Mode

This mode gives you the ability to program and execute moves, and reset errors when they occur. The command data formats are described in the following chapter.

Power Up Behavior

An SV Servo will power up in Configuration Mode if a configuration error exists. Valid configuration data can exist in several locations.

- 1) Configuration data is first read from flash memory.
- 2) If using EtherNet/IP with an EDS file, the SV Servo is sent configuration data when it connects to the network. This data is used to configure the unit. (This data is used in place of any configuration that may be stored in flash memory.)
- 3) If using PROFINET, the SV Servo is sent configuration data when it connects to the network. This data is used to configure the unit. (This data is used in place of any configuration that may be stored in flash memory.)

If the configuration data is valid, either retrieved from flash memory or written to it as part of the network connection process, the SV Servo will power up in Command Mode. The SV Servo will then check for valid network command data and will only enable the motor driver section if the Enable_Driver bit is set.

Data Format

An SV Servo requires twenty bytes of Output Data as well as twenty bytes of Input Data. These bytes are divided between single and double precision integers. The Data Endian parameter in the configuration data controls the format of double precision integers.

Command Mode Data Formats

When issuing commands to the SV Servo, there are several parameters that are larger than sixteen bits. These parameters are:

- Target Position
- Programmed Speed
- Stopping Distance
- Minimum Registration Move Distance
- Position Preset Value
- Position Unwind Value (used in Circular Virtual Axis Moves)

Likewise, when reading data back from an SV Servo while it is in Command Mode, there are values that are larger than sixteen bits. These data values are:

- Motion Profile Position
- Motor Shaft (Encoder) Position
- Trapped Encoder Position

By default, these thirty-two bit parameters and data values are written to and read from the SV Servo using the 32-bit double integer format with little endian format. Little endian format is used by the EtherNet/IP protocol. A configuration parameter called Data Endian can be used to select big endian format. Big endian format is typically used by both Modbus TCP and PROFINET controllers, but you should refer to your PLC’s documentation to verify the format used by your processor.

Examples of the formats are given below.

Value	32 bit Signed Integer Little Endian Format (EtherNet/IP)		32 bit Signed Integer Big Endian Format (PROFINET & Modbus TCP)	
	First Word	Second Word	First Word	Second Word
12	16#000C	16#0000	16#0000	16#000C
-12	16#FFF4	16#FFFF	16#FFFF	16#FFF4
1,234,567	16#D687	16#0012	16#0012	16#D687
-7,654,321	16#344F	16#FF8B	16#FF8B	16#344F

Table R5.1 Position Data Format Examples

PID Gain Calculations

Part of the configuration process is setting the PI gains for the velocity loop and the PID gains for the position loop. AMCI offers a software utility to help determine initial settings for these values.

The software is available on our website, www.amci.com. It is available in the *Support → Software* section of the website, <https://www.amci.com/industrial-automation-support/software/>. The title of the link is “AMCI Servo Gain Calculator”. Simply download the ZIP file, decompress it, and run the setup.exe file.

A help file is included with the software that explains the various settings. Note that calculated gain values may exceed their allowable range of 0 to 32,767. If this occurs, change the values for the Velocity Feedback Low Pass Filter Delay Time parameter and/or the Stiffness parameter and calculate the gains again.

Output Data Format

Multiple programming blocks are required to configure an SV Servo unit. Each data block is defined by the first two words of the block. The definition of these two words is the same for each block and is given below. The format of the remaining words depends on the block that is written to the unit at the time. EtherNet/IP, PROFINET, and Modbus TCP addresses are shown.

EtherNet/IP or PROFINET Word	Modbus TCP Register	Configuration Data	Range
0	1024	Configuration Word 0	See below
1	1025	Configuration Word 1	Reserved: Set to 0x0000
2	1026	Configuration Parameters Meaning and range depends on block written to SV Servo	
3	1027		
4	1028		
5	1029		
6	1030		
7	1031		
8	1032		
9	1033		

Table R5.2 Network Output Data Format: Configuration Mode

Configuration Word 0 Format

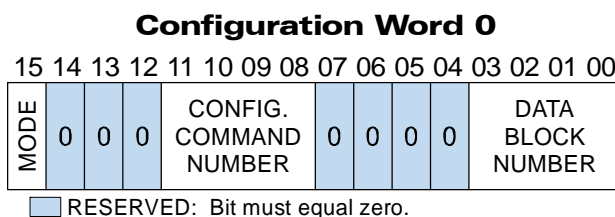

Figure R5.1 Configuration Mode: Control Word Format

- Bit 15: Mode_Select** – “1” for Configuration Mode Programming, “0” for Command Mode Programming.
- Bits 14 - 12: Reserved** – Must equal zero.
- Bits 11 - 08: Configuration Command Number** – These four bits define the Configuration Command that is being written to the SV Servo.
- Bits 07 - 04: Reserved** – Must equal zero.
- Bits 03 - 00: Data Block Number** – Programming configuration parameters require multiple associated blocks. These four bits are used to define the data block that is presently being written down to the SV Servo as part of the command.

Output Data Format (continued)

Configuration Commands

Configuration Command (Bits 11 - 08)	Description	Data Blocks (Bits 03-00)
0000 (0x0)	No Action	Not used. Set to 0x0.
0001 (0x1)	Read Extended Drive Status	Not used. Set to 0x0.
0010 (0x2)	Read back Configuration Parameter Block	0x0: Not Used 0x1: Data Configuration Block 0x2: I/O Configuration Block 0x3: Motor Configuration Block 0x4: RESERVED 0x5: Velocity Control Loop Block 0x6: Position Control Loop Block 0x7 - 0xE: RESERVED 0xF: Restore Factory Defaults to RAM
0011 (0x3)	RESERVED	Not used. Set to 0x0.
01xx (0x4 - 0x7)	RESERVED	Not used. Set to 0x0.
1000 (0x8)	No Action	Not used. Set to 0x0.
1001 (0x9)	RESERVED	Not used. Set to 0x0.
1010 (0xA)	Write Configuration Parameter Block	0x0: Not Used 0x1: Data Configuration Block 0x2: I/O Configuration Block 0x3: Motor Configuration Block 0x4: RESERVED 0x5: Velocity Control Loop Block 0x6: Position Control Loop Block 0x7 - 0x0E: RESERVED 0xF: Save Configuration to Flash
1011 (0xB)	RESERVED	Not used. Set to 0x0.
11xx (0xC - 0xF)	RESERVED	Not used. Set to 0x0.

Table R5.3 Configuration Command Values

Read Data Blocks

Extended Drive Status

Read Extended Drive Status Block	
15 14 13 12 11 10 09 08 07 06 05 04 03 02 01 00	
Word 0	0x8100
Word 1	Reserved. Set to 0x0000.
Word 2	Drive Firmware Revision Major in high byte, Minor in low byte. (example: 0x0102 = Revision 1.2)
Word 3-5	Factory Test Data
Word 6	Command Mode Status Word 0 Flags See <i>Status Word 0 Format</i> on page 76 for a description of the status bits.
Word 7	Command Mode Status Word 1 Flags See <i>Status Word 1 Format</i> on page 77 for a description of the status bits.
Word 8	Motor Bus Voltage (0.1 Vdc resolution) (example: 485 = 48.5 Vdc)
Word 9	CPU Temperature in °C (Accuracy ±1°C)

Figure R5.2 Configuration Mode: Extended Drive Status Block

Remaining Read Data Blocks

The remaining Read Data Block commands are used to report the present configuration data from the SV Servo to the host controller. The correct command word has to be in Configuration Word 0 and they are shown in the table below. All other words are ignored and should be set to zero. Once accepted, the SV Servo will respond by sending the requested data in its response. The format of the requested data is the same as the Write Data Blocks listed in the following sections.

Configuration Word Value	Description
0x8201	Data Configuration Values
0x8202	I/O Configuration Values
0x8203	Motor Configuration Values
0x8205	Velocity Control Loop Values
0x8206	Position Control Loop Values
0x820F	Restore Factory Defaults to RAM [†]

[†] Factory Defaults are restored to RAM memory. You must issue a Save Configuration to Flash command to store these values for use after a power cycle. (See page 59.)

Table R5.4 Additional Read Data Blocks

Write Data Blocks

Block 1: Data Configuration Block

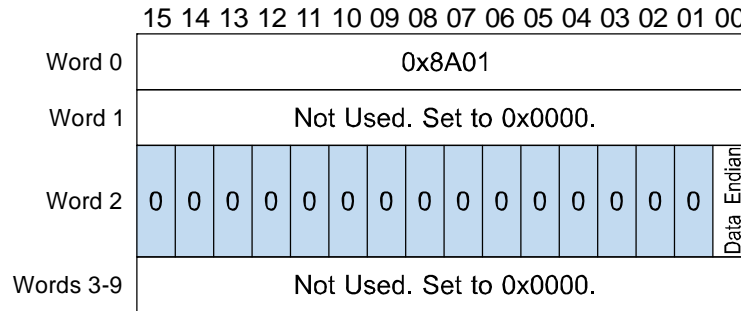

Figure R5.3 Data Configuration Block

Bit 0: **Data_Endian** – “0” for little endian format of thirty-two bit words. (EtherNet/IP default). “1” for big endian format of thirty-two bit words. (PROFINET and Modbus TCP default)

Block 2: I/O Configuration Block

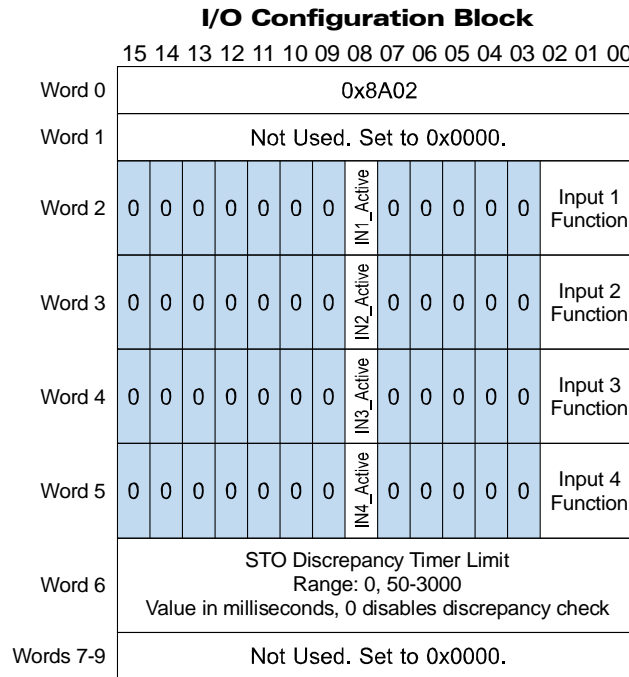

Figure R5.4 I/O Configuration Block

Bit 8: **Input Active State** – Determines the active state of the associated input. Set to “0” if your sensor has Normally Closed (NC) contacts and the input is active when there is no current flow through it. Set to “1” if your sensor has Normally Open (NO) contacts and current flows through the input when it is active.

➤ Inputs 3 and 4 on SV Servo units with the STO option must have their active state bits set to “1”.

Bits 3 - 0: **Input Function** – Sets the functionality of the associated input. See table R5.5 below. Note that, with the exception of a General Purpose Input, each input function can only be assigned to one input.

➤ Inputs 3 and 4 on SV Servo units with the STO option must have their functionality set to General Purpose (‘000’).

Write Data Blocks (continued)

Bits			Function	Available On
2	1	0		
0	0	0	General Purpose Input (Use for IN3 and IN4 on units with STO option)	The input is not used in any of the functions of the SV Servo, but its status is reported in the Network Data. This allows the input to be used as a discrete DC input to the host controller. IN3 and IN4 on units with the STO option must be set as General Purpose Inputs.
0	0	1	CW Limit	Input defines the mechanical end point for CW motion.
0	1	0	CCW Limit	Input defines the mechanical end point for CCW motion.
0	1	1	Trap Encoder Value & Start Indexed Move	An inactive-to-active state transition will trap the encoder position value and also trigger an Indexed Move if one is pending in the SV Servo.
1	0	0	Stop Jog or Registration Move	Triggers a controlled stop on a Jog or Registration Move and traps the encoder value at the trigger event.
1	0	1	Emergency Stop	All motion is immediately stopped when this input makes an inactive-to-active transition.
1	1	0	Home	Used to define the home position of the machine.
1	1	1	Invalid Combination	This bit combination is reserved.

Table R5.5 Input Function Selections

Block 3: Motor Configuration Block**Motor Configuration Block**

	15	14	13	12	11	10	09	08	07	06	05	04	03	02	01	00
Word 0	0x8A03															
Word 1	Reserved. Must equal zero.															
Word 2	Reserved. Must equal zero.															
Word 3	Reserved. Must equal zero.															
Word 4	Steps per Revolution. Must equal 16,384.															
Word 5	Reserved. Must equal zero.															
Word 6	Immediate Stop Deceleration 0, 1,500 to 15,999															
Word 7	Continuous Torque Limit SV160E2: Range of 10 to 50 (0.10 to 0.50 Nm) SV400E2: Range of 25 to 128 (0.25 to 1.28 Nm)															
Word 8	Peak Torque Limit SV160E2: Range of (Word 7 Value) to 130 SV400E2: Range of (Word 7 value) to 350															
Word 9	Over Voltage Threshold (55 to 100 V) Range of 0, 550 to 1000. (0 disables functionality)															

Figure R5.5 Motor Configuration Block

Write Data Blocks (continued)

Block 5: Velocity Control Loop Configuration Block

Velocity Configuration Block	
	15 14 13 12 11 10 09 08 07 06 05 04 03 02 01 00
Word 0	0x8A05
Word 1	Reserved. Must equal zero.
Word 2	Reserved. Must equal zero.
Word 3	Velocity Loop Proportional Gain (KP_VEL) Range of 0 to 32,767
Word 4	Velocity Loop Integral Gain (KI_VEL) Range of 0 to 32,767
Word 5	Reserved. Must equal zero.
Word 6	Velocity Feedback Low Pass Filter Range of 0 to 5 (milliseconds)
Words 7-9	Reserved. Must equal zero.

Figure R5.6 Velocity Control Loop Configuration Block

Note that the motor inertia of an SV160E2 is $48 \times 10^{-6} \text{ kg}\cdot\text{m}^2$. The motor inertia of an SV400E2 is $29 \times 10^{-6} \text{ kg}\cdot\text{m}^2$. AMCI suggests starting with a Velocity Loop Integral Gain, (word 4), of zero. This makes it easier to tune the position control loop later. With the Velocity Loop Integral Gain set to zero, the tables below shows reasonable defaults to use for the Velocity Loop Proportional Gain, (word 3), based on the value entered into the Velocity Feedback Low Pass Filter, (word 6). These values should work for most applications.

SV160E2 Velocity Loop Proportional Gain						
Load Inertia: Motor Inertia Ratio	Velocity Feedback Low Pass Filter Values					
	0	1	2	3	4	5
Unloaded	5561	2780	1854	1390	1112	927
1:1	11122	5561	3707	2780	2224	1854
2:1	16683	8341	5561	4171	3337	2780
3:1	22244	11122	7415	5561	4449	3707
4:1	27805	13902	9268	6951	5561	4634
5:1	DNU [†]	16683	11122	8341	6673	5561
6:1	DNU	19463	12975	9732	7785	6488
7:1	DNU	22244	14829	11122	8897	7415
8:1	DNU	25024	16683	12512	10010	8341
9:1	DNU	27805	18536	13902	11122	9268
10:1	DNU	30585	20390	15292	12234	10195
12:1	DNU	DNU	24097	18073	14458	12049
14:1	DNU	DNU	27805	20853	16683	13902
16:1	DNU	DNU	31512	23634	18907	15756
18:1	DNU	DNU	DNU	26414	21131	17610
20:1	DNU	DNU	DNU	29195	23356	19463

[†] DNU: Do Not Use

Table R5.6 SV160E2 Velocity Loop Proportional Gain Values

Write Data Blocks (continued)**Block 5: Velocity Control Loop Configuration Block (continued)**

Load Inertia: Motor Inertia Ratio	SV400E2 Velocity Loop Proportional Gain					
	Velocity Feedback Low Pass Filter Values					
	0	1	2	3	4	5
Unloaded	1174	587	391	293	235	196
1:1	2347	1174	782	587	469	391
2:1	3521	1761	1174	880	704	587
3:1	4695	2347	1565	1174	939	782
4:1	5869	2934	1956	1467	1174	978
5:1	7042	3521	2347	1761	1408	1174
6:1	8216	4108	2739	2054	1643	1369
7:1	9390	4695	3130	2347	1878	1565
8:1	10563	5282	3521	2641	2113	1761
9:1	11737	5869	3912	2934	2347	1956
10:1	12911	6455	4304	3228	2582	2152
12:1	15258	7629	5086	3815	3052	2543
14:1	17606	8803	5869	4401	3521	2934
16:1	19953	9976	6651	4988	3991	3325
18:1	22300	11150	7433	5575	4460	3717
20:1	24648	12324	8216	6162	4930	4108

Table R5.7 SV400E2 Velocity Loop Proportional Gain Values

Write Data Blocks (continued)

Block 6: Position Control Loop Configuration Block

Position Configuration Block	
	15 14 13 12 11 10 09 08 07 06 05 04 03 02 01 00
Word 0	0x8A06
Word 1	Reserved. Must equal zero.
Word 2	Reserved. Must equal zero.
Word 3	Position Loop Proportional Gain (KP_POS) Range of 0 to 32,767
Word 4	Position Loop Integrative Gain (KI_POS) Range of 0 to 32,767
Word 5	Position Loop Derivative Gain (KD_POS) Range of 0 to 32,767
Word 6	Stall Detect: Maximum Position Error Limit Range of 0 to 32,767
Word 7	At Rest Proportional Gain Range of 0 to 32,767
Word 8	At Rest Integral Gain Range of 0 to 32,767
Word 9	Reserved. Must equal zero.

Figure R5.7 Position Control Loop Configuration Block

The table below shows reasonable defaults for use as position control loop values for both the SV160E2 and the SV400E2. These values are based on how closely the unit must track the position. This is often referred to as the shaft’s “stiffness”. As the stiffness is increased, the SV Servo will react faster to small positional errors. This results in better positional tracking, but may result in more ringing in response to a position change.

		KP_POS	KI_POS	KD_POS
Shaft Stiffness	Increasing Stiffness ↓	728	54	0
		874	78	0
		1092	121	0
		1456	216	0
		2185	485	0
		4369	1942	0
		6554	4369	0

Table R5.8 SV Servo Position Loop Values

By default, the SV Servo uses a KP_Pos value of 5243 and a KI_Pos of 2796 when there is zero motion. This provides positional accuracy, but these values may cause oscillations in systems where the load is not tightly coupled to the motor, such as belt driven systems. For these applications, the At Rest Proportional Gain and At Rest Integral Gain should be programmed and these values will be used in the position loop when the velocity equals zero. The At Rest gains are used if the At Rest Proportional Gain is a non-zero value.

NOTE  Only the At Rest Proportional Gain value is checked to see if it is a non-zero value. This allows you to use an At Rest Integral Gain value of zero. (Proportional control loop.)

Write Data Blocks (continued)

Block 15: Save Configuration To Flash Block

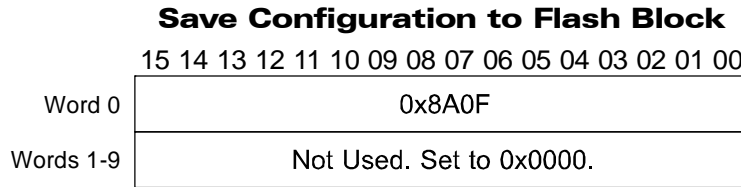

Figure R5.8 Save Configuration to Flash Block



This command block will also save any calculated position offsets from a preset command or homing operation.

Input Data Format

The format of the Network Input Data when the SV Servo is in Configuration Mode is dependant on the last configuration command written to the unit. With the exception of the first two words, the data format of the response is the same as that of the *Write Data Blocks* that are listed starting on page 54.

Configuration Mode Input Word 0

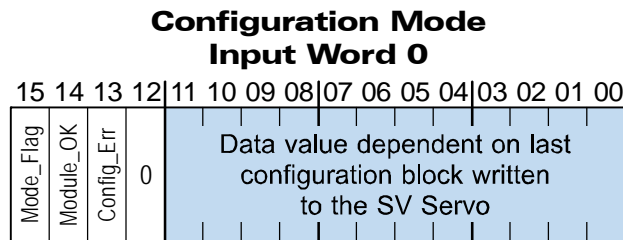

Figure R5.9 Configuration Mode Input Word 0

- Bit 15: Mode_Flag** – Set to “1” when the SV Servo is writing a configuration data response to the host controller. Reset to “0” when writing a command data response to the host controller.
- Bit 14: Module_OK** – Set to “1” when the SV Servo is operating without error. Reset to “0” when the SV Servo is experiencing a hardware issue.
- Bit 13: Config_Error** – Set to “1” when the last configuration block written to the SV Servo has an error, or when you attempt to exit configuration mode and a configuration error still exists.
- Bit 12: Reserved** – Will always equal zero.

Input Data Format (continued)

Configuration Mode Input Word 0 (continued)

Bits 11- 00: Command/Data Block Numbers – Once the SV Servo responds to the configuration block, the unit will echo the Command and Data Block numbers in these bits. In the case of Write Configuration blocks, if there is an error in the data, bit 13 of this word is set to “1” and additional data is available in Input Word 1. Table R5.9 below shows the available bit patterns.

Configuration Command (Bits 11 - 08)	Description	Data Blocks (Bits 03-00)
0001 (0x1)	Read Extended Drive Status	Not used. Set to 0x0.
0010 (0x2)	Read back Configuration Parameter Block	0x0: Not Used 0x1: Data Configuration Block 0x2: I/O Configuration Block 0x3: Motor Configuration Block 0x5: Velocity Control Loop Block 0x6: Position Control Loop Block 0xF: Restore Factory Defaults to RAM
1010 (0xA)	Write Configuration Parameter Block	0x0: Not Used 0x1: Data Configuration Block 0x2: I/O Configuration Block 0x3: Motor Configuration Block 0x5: Velocity Control Loop Block 0x6: Position Control Loop Block 0xF: Save Configuration to Flash

Table R5.9 Configuration Command Values

Configuration Mode Input Word 1

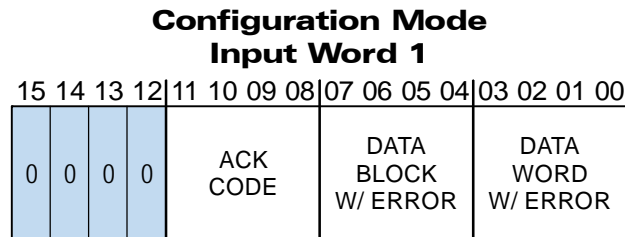

Figure R5.10 Configuration Mode Input Word 1

Input Data Format (continued)**Configuration Mode Input Word 1 (continued)**

Bits 11- 08: Acknowledgement Code – An Acknowledgement Code is written in response to the last configuration block written to the SV Servo.

Acknowledgement Code	Description
0000 (0x0)	No Configuration blocks have been written to the SV Servo since a power cycle, or the last Configuration Command was “No Action” (See table R5.3, page 52.)
0001 (0x1)	The last read or write configuration block completed successfully.
1000 (0x8)	The last write configuration block command contained an error in the data. Bits 7 through 0 of this word contains diagnostic data.
1001 (0x9)	The last write configuration block command used an invalid command or data block code. See table R5.3, page 52 for a list of valid commands.
1010 (0xA)	Save to flash memory error. Cycle power to the SV Servo to clear this error.

Table R5.10 Configuration Command Values

Bits 07- 04: Data Block with Error – These four bits equal “0000” if the Acknowledgement Code equals zero or one. If there is an error, these four bits contains the Data Block number that has the error.

Bits 03- 00: Data Word with Error – These four bits equal “0000” if the Acknowledgement Code equals zero or one. If there is an error, these four bits contains the number of the word that has the error. Refer to the data block formats given in the *Write Data Blocks* section of this chapter starting on page 54.

Invalid Configurations

The following configurations are invalid:

- 1) Setting any of the reserved bits in the configuration words.
- 2) Setting the motor steps per turn to any value other than 16,384.
- 3) Setting any parameter to a value outside of its valid range.
- 4) You configure two or more inputs to have the same function, such as two CW Limit Switches. (An error does not occur if both are configured as General Purpose Inputs.)
- 5) Setting the Input Configuration bits for any input to “111”. See table R5.5 on page 55 for more information.
- 6) On SV Servo units wit the STO option, programming inputs 3 or 4 to any other function than General Purpose Input with an Active High state setting.

Notes

REFERENCE 6

COMMAND MODE DATA FORMAT

This chapter covers the formats of the Network Output Data used to command an SV Servo and the formats of the Network Input Data that contains the responses from the device. An SV Servo requires twenty bytes of Output Data as well as twenty bytes for Input Data.

Command Bits Must Transition

Commands are only accepted when a command bit makes a 0→1 transition and only one bit can make this transition at a time. (All other bits must be zero.) The easiest way to do this is to write a value of zero into the Command Word 0 before writing the next command.

This condition also applies when switching from Configuration Mode to Command Mode. If a bit is set in Configuration Word 0 while in Configuration Mode and you switch to Command Mode with the same bit set, the command will not occur because the bit must transition between writes to the unit.

The command bits are split between two 16-bit words, Command Word 0 and Command Word 1. Only one bit in Command Word 0 can make a 0→1 transition at a time. All other bits in Command Word 0 must be zero.

Data Format

An SV Servo requires twenty bytes of Output Data as well as twenty bytes of Input Data. These bytes are a mix of sixteen and thirty-two bit integers.

EtherNet/IP uses the little endian format for thirty-two bit integers, while PROFINET and Modbus TCP uses big endian format by default. The endian format used by the SV Servo is programmable in the configuration data using the Data_Endian parameter. The default is little endian.

Output Data Format

The following table shows the format of the output network data words when writing command data to the SV Servo. EtherNet/IP, PROFINET, and Modbus TCP address are shown.

EtherNet/IP or PROFINET Word	Modbus/TCP Register	Function
0	1024	Command Word 0
1	1025	Command Word 1
2	1026	Command Parameters Word meaning depends on the command sent to the SV Servo
3	1027	
4	1028	
5	1029	
6	1030	
7	1031	
8	1032	
9	1033	

Figure R6.1 Command Data Format

Command Word 0

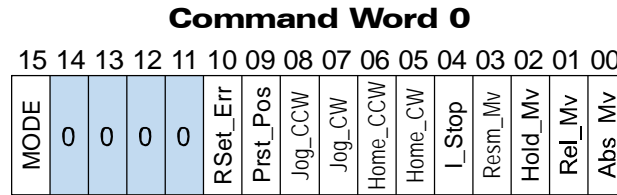

Figure R6.2 Command Word 0 Format

Bit 15: Mode_Select – “1” for Configuration Mode Programming. “0” for Command Mode Programming.

Bits 14 - 11: Reserved – Must equal zero.

Bit 10: Reset_Errors – When this bit makes a 0→1 transition, the SV Servo will clear all command and input errors and reset the *Move_Complete* bit in the Network Input Data. This bit does not clear a configuration error or the *Position_Invalid* status bit.

Bit 9: Preset_Position – When this bit makes a 0→1 transition, the SV Servo will preset the Profile Position and the Encoder Position to the value specified in the command. The *Move_Complete* and *Position_Invalid* bits in the Network Input Data are reset to “0”.

Bit 8: Jog_CCW – When this bit makes a 0→1 transition, the SV Servo will run a Jog Move in the counter-clockwise direction. The full explanation of a *CW/CCW Jog Move* can be found starting on page 35.

- **Registration_Move – Command Word 1, Bit 7:** When this bit equals “0”, and a Jog Move command is issued, it will run as a standard Jog Move. When this bit equals “1” and a Jog Move command is issued, the move will run as a Registration Move.

- **Axis Follower Mode – Command Word 1, Bit 12:** If this bit equal “1” when the Registration_Move bit equals “0”, the SV Servo will enter its Virtual Axis Follower Mode when the Jog Move bit makes a 0→1 transition.

Bit 7: Jog_CW – When this bit makes a 0→1 transition, the SV Servo will run a Jog Move in the clockwise direction. The full explanation of a *CW/CCW Jog Move* can be found starting on page 35.

- **Registration_Move – Command Word 1, Bit 7:** When this bit equals “0”, and a Jog Move command is issued, it will run as a standard Jog Move. When this bit equals “1” and a Jog Move command is issued, the move will run as a Registration Move.

- **Axis Follower Mode – Command Word 1, Bit 12:** If this bit equal “1” when the Registration_Move bit equals “0”, the SV Servo will enter its Virtual Axis Follower Mode when the Jog Move bit makes a 0→1 transition.

Bit 6: Find_Home_CCW – When this bit makes a 0→1 transition, the SV Servo will attempt to move to the Home Limit Switch in the counter-clockwise direction. A full explanation of homing can be found in the *Homing an SV Servo Controller* reference chapter starting on page 45.

Bit 5: Find_Home_CW – When this bit makes a 0→1 transition, the SV Servo will attempt to move to the Home Limit Switch in the clockwise direction. A full explanation of homing can be found in the *Homing an SV Servo Controller* reference chapter starting on page 45.

Bit 4: Immediate_Stop – When this bit makes a 0→1 transition, the SV Servo will stop all motion at the deceleration rate programmed with the Immediate Stop Deceleration value. (The Immediate Stop Deceleration is programmed as part of the configuration data, **Block 3: Motor Configuration Block**, as described on page 55.) If the position error during the stop does not exceed the Maximum Position Error Limit value, the motor will stop at the Profile Position value. If the position error during the stop exceeds the Maximum Position Error Limit value, the SV Servo will disable the motor and issue a Position_Invalid fault. The Maximum Position Error Limit value is programmed as part of the **Block 6: Position Control Loop Configuration Block** found on page 58.

Command Word 0 (continued)

- Bit 3: Resume_Move** – When this bit makes a 0→1 transition, the SV Servo will resume a move that you previously placed in a hold state. Use of the Resume_Move and Hold_Move bits can be found in the *Controlling Moves In Progress* section of this manual starting on page 40. Note that a move in its hold state need not be resumed. The move is automatically cancelled if another move is started in its place.
- Bit 2: Hold_Move** – When this bit makes a 0→1 transition, the SV Servo will place a move in its hold state. The move will decelerate and stop. The move can be completed by using the Resume_Move bit. Use of the Hold_Move and Resume_Move bits can be found in the *Controlling Moves In Progress* section of this manual starting on page 40.
- Bit 1: Relative_Move** – When this bit makes a 0→1 transition, the SV Servo will perform a Relative Move using the data in the rest of the Command Data. The full explanation of a *Relative Move* can be found starting on page 33.
- Bit 0: Absolute_Move** – When this bit makes a 0→1 transition, the SV Servo will perform an Absolute Move using the data in the rest of the Command Data. The full explanation of an *Absolute Move* can be found starting on page 34.

Command Word 1

Figure R6.3 Command Word 1 Format

- Bit 15: Enable_Driver** – “0” to disable the motor current, A 0→1 transition attempts to enable motor current. A valid configuration must be written to the SV Servo before the driver can be enabled. Additionally, the Encoder Position must be within the range of Profile Position $\pm 4,096$ counts or the Preset_on_Enable bit, bit 14 of this word, must be set to “1”. On SV Servo units with the STO option, the Enable_Driver bit must make a 0→1 transition as the last step when recovering from a STO event.
- Bit 14: Preset_on_Enable** – Only used when the Enable_Driver bit makes a 0→1 transition. If this bit is set during a transition on the Enable_Driver bit, the Profile Position is set equal to the current Encoder Position when the motor is enabled. If this bit is not set during a transition on the Enable_Driver bit, the Encoder Position must be within the range of Profile Position $\pm 4,096$ counts to enable the driver. Once enabled, the *Move_Complete* bit in the Network Input Data is reset to “0”.
- Bit 13: Reserved** – Must equal “0”.
- Bit 12: Virtual_Axis_Follower** – Set to “1” when using the SV Servo as an axis follower. The Jog_CCW and Jog_CW bits are used to control when the move actually occurs.
- Bits 11-9: Reserved** – Must equal “0”.
- Bit 8: Indexed_Command** – If this bit is set when a move command is issued, the SV Servo will not run the move immediately, but will instead wait for an inactive-to-active transition on an input configured as a *Start Indexed Move* input. The move command data, including this bit, must remain in the Network Output Registers while performing an Indexed Move.

Command Word 1 (continued)

Bit 7: Registration_Move – When this bit equals “0”, and a Jog Move command is issued, it will run as a standard Jog Move. When this bit equals “1” and a Jog Move command is issued, the move will run as a Registration Move.

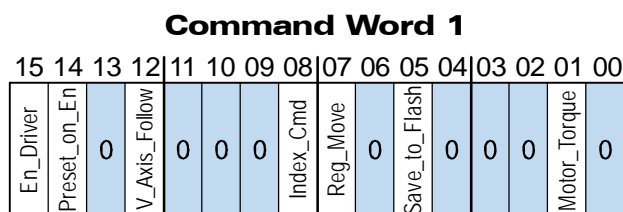
Bit 6: Reserved – Must equal “0”.

Bit 5: Save_to_Flash – This bit can be used to store the position offset to flash. (The position offset is generated by the Preset Position command or a homing operation.)

- When using this bit to save the calculated offset value to flash memory, this bit must be set when the Preset Position command is issued. (Bit 9 of *Command Word 0* is set to “1”, see page 64.) If the offset is stored without error, the unit will respond by setting the Acknowledge bit. (Bit 13 of *Status Word 1 Format*, see page 77.)
- This bit will also save the present configuration data to flash memory.

Bits 4-2: Reserved – Must equal “0”.

Bit 1: Set Maximum Move Torque – Reset to “0” to use the Peak and Continuous Torque values specified in the Configuration Data for the move. Set to “1” to program the maximum Move Torque value in word 8 of the command block. This value is used in place of the Peak and Continuous Torque values for this move.



Except for jog and virtual axis moves, the torque is set when the move is started. The torque can only be programmed as part of the move command.

Bit 0: Reserved – Must equal “0”.

Command Blocks

The following section lists the output data format for the sixteen different commands.

Absolute Move

EtherNet/IP or PROFINET Word	Modbus/TCP Register	Function	Units	Range
0	1024	<i>Command Word 0</i>		16#0001
1	1025	<i>Command Word 1</i>		See pg. 65
2	1026	32 bit Absolute Target Position	Steps	Range of -1,073,741,824 to +1,073,741,823
3	1027			
4	1028	32 bit Programmed Speed	Steps/Second	Range of 1 to 1,048,575
5	1029			
6	1030	Acceleration	Steps/sec/ms	1 to 15,999
7	1031	Deceleration	Steps/sec/ms	1 to 15,999
8	1032	Maximum Move Torque	0.01 Nm	SV160E2: 0, 10 to 130. SV400E2: 0, 25 to 350. “0” only allowed if bit 1 of Command Word 1 is “0”.
9	1033	Reserved		Must be 0

Table R6.1 Absolute Move Command Block

Command Blocks (continued)**Relative Move**

EtherNet/IP or PROFINET Word	Modbus/TCP Register	Function	Units	Range
0	1024	<i>Command Word 0</i>		16#0002
1	1025	<i>Command Word 1</i>		See pg. 65
2	1026	32 bit Relative Target Position	Steps	Range of -1,073,741,824 to +1,073,741,823
3	1027			
4	1028	32 bit Programmed Speed	Steps/Second	Range of 1 to 1,048,575
5	1029			
6	1030	Acceleration	Steps/sec/ms	1 to 15,999
7	1031	Deceleration	Steps/sec/ms	1 to 15,999
8	1032	Maximum Move Torque	0.01 Nm	SV160E2: 0, 10 to 130. SV400E2: 0, 25 to 350. "0" only allowed if bit 1 of Command Word 1 is "0".
9	1033	Reserved		Must be 0

Table R6.2 Relative Move Command Block

Hold Move

EtherNet/IP or PROFINET Word	Modbus/TCP Register	Function	Units	Range
0	1024	<i>Command Word 0</i>		16#0004
1	1025	<i>Command Word 1</i>		See pg. 65
2	1026	Unused		See Note Below
3	1027	Unused		See Note Below
4	1028	Unused		See Note Below
5	1029	Unused		See Note Below
6	1030	Unused		See Note Below
7	1031	Unused		See Note Below
8	1032	Unused		See Note Below
9	1033	Unused		See Note Below

Table R6.3 Hold Move Command Block

Unused words are ignored by the SV Servo and can be any value, including parameter values from the previous command.

Command Blocks (continued)

Resume Move

EtherNet/IP or PROFINET Word	Modbus/TCP Register	Function	Units	Range
0	1024	<i>Command Word 0</i>		16#0008
1	1025	<i>Command Word 1</i>		See pg. 65
2	1026	Unused		See Note Below
3	1027	Unused		See Note Below
4	1028	32 bit Programmed Speed	Steps/Second	Range of 1 to 1,048,575
5	1029			
6	1030	Acceleration	Steps/sec/ms	1 to 15,999
7	1031	Deceleration	Steps/sec/ms	1 to 15,999
8	1032	Maximum Move Torque	0.01 Nm	SV160E2: 0, 10 to 130. SV400E2: 0, 25 to 350. “0” only allowed if bit 1 of Command Word 1 is “0”.
9	1033	Reserved		Must be 0

Table R6.4 Resume Move Command Block

Unused words are ignored by the SV Servo and can be any value, including parameter values from the previous command. This is typically the case when resuming a move, the words are listed as “Unused” to highlight that the target position of a held move cannot be changed when the move is resumed.

Immediate Stop

EtherNet/IP or PROFINET Word	Modbus/TCP Register	Function	Units	Range
0	1024	<i>Command Word 0</i>		16#0010
1	1025	<i>Command Word 1</i>		See pg. 65
2	1026	Unused		See Note Below
3	1027	Unused		See Note Below
4	1028	Unused		See Note Below
5	1029	Unused		See Note Below
6	1030	Unused		See Note Below
7	1031	Unused		See Note Below
8	1032	Unused		See Note Below
9	1033	Unused		See Note Below

Table R6.5 Immediate Stop Command Block

Unused words are ignored by the SV Servo and can be any value, including parameter values from the previous command.

Command Blocks (continued)**Find Home CW**

EtherNet/IP or PROFINET Word	Modbus/TCP Register	Function	Units	Range
0	1024	<i>Command Word 0</i>		16#0020
1	1025	<i>Command Word 1</i>		See pg. 65
2	1026	Unused		See Note Below
3	1027	Unused		See Note Below
4	1028	32 bit Programmed Speed	Steps/Second	Range of 1 to 1,048,575
5	1029			
6	1030	Acceleration	Steps/sec/ms	1 to 15,999
7	1031	Deceleration	Steps/sec/ms	1 to 15,999
8	1032	Maximum Move Torque	0.01 Nm	SV160E2: 0, 10 to 130. SV400E2: 0, 25 to 350. “0” only allowed if bit 1 of Command Word 1 is “0”.
9	1033	Reserved		Must be 0

Table R6.6 Find Home CW Command Block

Unused words are ignored by the SV Servo and can be any value, including parameter values from the previous command.

Find Home CCW

EtherNet/IP or PROFINET Word	Modbus/TCP Register	Function	Units	Range
0	1024	<i>Command Word 0</i>		16#0040
1	1025	<i>Command Word 1</i>		See pg. 65
2	1026	Unused		See Note Below
3	1027	Unused		See Note Below
4	1028	32 bit Programmed Speed	Steps/Second	Range of 1 to 1,048,575
5	1029			
6	1030	Acceleration	Steps/sec/ms	1 to 15,999
7	1031	Deceleration	Steps/sec/ms	1 to 15,999
8	1032	Maximum Move Torque	0.01 Nm	SV160E2: 0, 10 to 130. SV400E2: 0, 25 to 350. “0” only allowed if bit 1 of Command Word 1 is “0”.
9	1033	Reserved		Must be 0

Table R6.7 Find Home CCW Command Block

Unused words are ignored by the SV Servo and can be any value, including parameter values from the previous command.

Command Blocks (continued)

Jog CW

EtherNet/IP or PROFINET Word	Modbus/TCP Register	Function	Units	Range
0	1024	<i>Command Word 0</i>		16#0080
1	1025	<i>Command Word 1</i>		See pg. 65 Bit 7 must equal "0"
2	1026	Unused		See Note Below
3	1027	Unused		See Note Below
4	1028	32 bit Programmed Speed	Steps/Second	Range of 1 to 1,048,575
5	1029			
6	1030	Acceleration	Steps/sec/ms	1 to 15,999
7	1031	Deceleration	Steps/sec/ms	1 to 15,999
8	1032	Maximum Move Torque	0.01 Nm	SV160E2: 0, 10 to 130. SV400E2: 0, 25 to 350. "0" only allowed if bit 1 of Command Word 1 is "0".
9	1033	Reserved		Must be 0

Table R6.8 Jog Move CW Command Block

Unused words are ignored by the SV Servo and can be any value, including parameter values from the previous command.

Registration Move CW

EtherNet/IP or PROFINET Word	Modbus/TCP Register	Function	Units	Range
0	1024	<i>Command Word 0</i>		16#0080
1	1025	<i>Command Word 1</i>		See pg. 65 Bit 7 must equal "1"
2	1026	32 bit Stopping Distance	Steps	Range of 1 to 1,073,741,823
3	1027			
4	1028	32 bit Programmed Speed	Steps/Second	Range of 1 to 1,048,575
5	1029			
6	1030	Acceleration	Steps/sec/ms	1 to 15,999
7	1031	Deceleration	Steps/sec/ms	1 to 15,999
8	1032	32 bit Minimum Registration Move Distance	Steps	Range of 0 to +1,073,741,823
9	1033			

Table R6.9 Registration Move CW Command Block

Command Blocks (continued)**Axis Follower Moves**

The Axis Follower Moves requires a controller with the capacity for motion axis programming. The following table is offered as a troubleshooting aid if you need to decode the data being sent to the SV Servo.

EtherNet/IP or PROFINET Word	Modbus TCP Register	Function	Units	Range
0	1024	<i>Command Word 0</i>		16#0080 or 16#0100
1	1025	<i>Command Word 1</i>		See pg. 65 Bit 12 must equal "1"
2	1026	32 bit Position Value	Steps	Range of -1,073,741,824 to +1,073,741,823
3	1027			
4	1028	32 bit Programmed Speed	Steps/Second	Range of ±1,048,575
5	1029			
6	1030	Acceleration	Steps/ms/sec	Range of ±15,999
7	1031	Deceleration	Steps/ms/sec	1 to 15,999
8	1032	32 bit Unwind Value or Maximum Move Torque	Steps or 0.01 Nm	0, 1,024 to 1,073,741,824 or 0, 10 to 130 for SV160E2 0, 25 to 350 for SV400E2
9	1033			

Table R6.10 Axis Follower Move Command Block

When the command is accepted, the value in words 8 and 9 determine the type of move. If the value equals zero, the move is treated as a linear axis follower. If the value is between 1,024 and 1,073,741,824, the move is treated as a circular axis follower. Once the move has begun, the type of follower move cannot be changed.

Once the command is accepted, the *Stopped* bit (Word 0, bit 3 in the Input Data), is reset to "0" and remains zero as long as the axis follower command remains active. It will not be reset to zero if the position from the master axis stops changing. Use the *Moving_CW* and *Moving_CCW* bits (Word 0, bits 0 and 1 in the Input Data), to determine when motion from the SV Servo is occurring.

When the command is accepted, the acceleration programmed in word 6 is used to accelerate to the present speed of the move. Once this speed is achieved, the SV Servo will use the value in word 6 to determine how quickly it reacts to the changes in position from the master axis. (Once the SV Servo initially accelerates to the preset speed of the virtual axis, the unit accepts changes in the acceleration value in word 6 as part of the virtual axis commands.)

Once the SV Servo is following the axis, (the *Stopped* bit is reset to "0"), Word 8 can be used to program the Maximum Move Torque. The *Motor_Torque* bit (Command Word 1, bit 1) must be set to "1" to program the torque. The Maximum Move Torque must be in word 8 and word 9 must equal 0.

A sample program that demonstrates virtual axis programming on ControlLogix is available on the AMCI website at <https://www.amci.com/industrial-automation-support/sample-programs/>. The Linear and Circular Add On Instructions available in the sample program, have all of the above parameters and automatically place the values in the correct registers based on the state of the Stopped status bit.

If you are using a different host controller that supports motion axis programming, feel free to contact AMCI technical support for assistance in programming your controller.

Command Blocks (continued)

Jog CCW

EtherNet/IP or PROFINET Word	Modbus/TCP Register	Function	Units	Range
0	1024	<i>Command Word 0</i>		16#0100
1	1025	<i>Command Word 1</i>		See pg. 65 Bit 7 must equal "0"
2	1026	Unused		See Note Below
3	1027	Unused		See Note Below
4	1028	32 bit Programmed Speed	Steps/Second	Range of 1 to 1,048,575
5	1029			
6	1030	Acceleration	Steps/sec/ms	1 to 15,999
7	1031	Deceleration	Steps/sec/ms	1 to 15,999
8	1032	Maximum Move Torque	0.01 Nm	SV160E2: 0, 10 to 130. SV400E2: 0, 25 to 350. "0" only allowed if bit 1 of Command Word 1 is "0".
9	1033	Reserved		Must be 0

Table R6.11 Jog CCW Command Block

Unused words are ignored by the SV Servo and can be any value, including parameter values from the previous command.

Registration Move CCW

EtherNet/IP or PROFINET Word	Modbus/TCP Register	Function	Units	Range
0	1024	<i>Command Word 0</i>		16#0100
1	1025	<i>Command Word 1</i>		See pg. 65 Bit 7 must equal "1"
2	1026	32 bit Stopping Distance	Steps	Range of 1 to 1,073,741,823
3	1027			
4	1028	32 bit Programmed Speed	Steps/Second	Range of 1 to 1,048,575
5	1029			
6	1030	Acceleration	Steps/sec/ms	1 to 15,999
7	1031	Deceleration	Steps/sec/ms	1 to 15,999
8	1032	32 bit Minimum Registration Move Distance	Steps	Range of 0 to +1,073,741,823
9	1033			

Table R6.12 Registration Move CCW Command Block

Command Blocks (continued)**Preset Position**

EtherNet/IP or PROFINET Word	Modbus/TCP Register	Function	Units	Range
0	1024	<i>Command Word 0</i>		16#0200
1	1025	<i>Command Word 1</i>		16#0000: Save to RAM 16#0020: Save to Flash
2	1026	32 bit Position Preset Value	Steps	Range of -1,073,741,824 to +1,073,741,823
3	1027			
4	1028	Unused		See Note Below
5	1029	Unused		See Note Below
6	1030	Unused		See Note Below
7	1031	Unused		See Note Below
8	1032	Unused		See Note Below
9	1033	Unused		See Note Below

Table R6.13 Preset Position Command Block

Unused words are ignored by the SV Servo and can be any value, including parameter values from the previous command.

Presetting the position resets the *Position_Invalid* and *Move_Complete* status bits in the Network Input Data. When accepted, the Profile Position and Encoder Position are both set to the preset value.

Reset Errors

EtherNet/IP or PROFINET Word	Modbus/TCP Register	Function	Units	Range
0	1024	<i>Command Word 0</i>		16#0400
1	1025	<i>Command Word 1</i>		See pg. 65
2	1026	Unused		See Note Below
3	1027	Unused		See Note Below
4	1028	Unused		See Note Below
5	1029	Unused		See Note Below
6	1030	Unused		See Note Below
7	1031	Unused		See Note Below
8	1032	Unused		See Note Below
9	1033	Unused		See Note Below

Table R6.14 Reset Errors Command Block

Unused words are ignored by the SV Servo and can be any value, including parameter values from the previous command.

Resetting errors will also reset the *Move_Complete*, *Stall_Detected*, *Invalid_Jog_Change*, and *Connection_Was_Lost* status bit in the Network Input Data. Resetting errors will not reset the *Position_Invalid* or *Configuration_Error* bits.

Command Blocks (continued)

Enable Driver or Preset On Enable

EtherNet/IP or PROFINET Word	Modbus/TCP Register	Function	Units	Range
0	1024	<i>Command Word 0</i>		16#0000
1	1025	<i>Command Word 1</i>		16#8000 or 16#C000
2	1026	Unused		See Note Below
3	1027	Unused		See Note Below
4	1028	Unused		See Note Below
5	1029	Unused		See Note Below
6	1030	Unused		See Note Below
7	1031	Unused		See Note Below
8	1032	Unused		See Note Below
9	1033	Unused		See Note Below

Table R6.15 Enable Driver Command Block

When Command Word 1 equals 16#8000 the Profile Position must be within the range of the Encoder Position $\pm 4,096$ counts or the driver will not enable.

When Command Word 1 equals 16#C000 the Profile Position will be preset to the encoder position before the driver is enabled.

Unused words are ignored by the SV Servo and can be any value, including parameter values from the previous command.

Disable Driver

EtherNet/IP or PROFINET Word	Modbus/TCP Register	Function	Units	Range
0	1024	<i>Command Word 0</i>		16#0000
1	1025	<i>Command Word 1</i>		Bit 15 = '0'
2	1026	Unused		See Note Below
3	1027	Unused		See Note Below
4	1028	Unused		See Note Below
5	1029	Unused		See Note Below
6	1030	Unused		See Note Below
7	1031	Unused		See Note Below
8	1032	Unused		See Note Below
9	1033	Unused		See Note Below

Table R6.16 Disable Driver Command Block

Disabling the driver during a move will result in a controlled stop and the SV Servo will issue a command error response.

Input Data Format

The correct format for the Network Input Data when the SV Servo is in Command Mode is shown below.

EtherNet/IP or PROFINET Word	Modbus/TCP Register	Command Mode Input Data
0	0	Status Word 0
1	1	Status Word 1
2	2	32 bit Profile Position
3	3	
4	4	32 bit Encoder Position
5	5	
6	6	Trapped Encoder Position
7	7	
8	8	Actual Peak Motor Current [†] (X100)
9	9	Actual Motor Velocity [†] (counts per millisecond)

[†] Motor current and velocity will be negative values when the position value is decreasing.

Table R6.17 Network Input Data Format: Command Mode

The range of the three position values, (Profile, Encoder, and Trapped Encoder) is -1,073,741,824 to +1,073,741,823. In the cases of the Profile and Encoder Positions, if a position value increments or decrements past these limits, the reported position value will “roll over” to the largest negative or positive value and continue to increment or decrement from there.

Profile Position (Words 2 and 3)

This is the calculated position from the motion profile that is generated when the motion command is executed. It represents the ideal position of the motor shaft when the data is reported.

Encoder Position (Words 4 and 5)

This is the actual position of the motor shaft when the data is reported.

Trapped Encoder Position (Words 6 and 7)

This is the last trapped encoder position value.

Actual Motor Current (Word 8)

This value represents the peak motor current at the time the data was reported. It has units of 0.01 amps. This value is positive when the motor shaft is rotating clockwise when looking at the shaft. This value is negative when the motor shaft is rotating counter-clockwise.

The torque that is being produced by the motor can be estimated with the following formula:

$$Torque = I_m \div 100 \div 1.414 \times TC$$

$Torque$ = Instantaneous motor torque in Nm.

I_m = Actual Motor Current reported in Word 8.

TC = Torque Constant:

0.124 Nm/Arms for SV160E2, 0.136 Nm/Arms for SV400E2

I_{max} = Maximum Resistor Current (10 A for SV160E2. 15 A for SV400E2)

Input Data Format (continued)

Actual Motor Velocity (Word 9)

This is the velocity of the motor at the time the data was reported. The reported units are encoder counts per millisecond. Multiply the reported value by 1000 to convert to counts per second. The encoder has a fixed resolution of 16,384 counts per turn. To convert the velocity to revolutions per second, multiply the reported value by (1,000/16,384). To convert to RPM, multiply the reported value by (100/98,304).

Status Word 0 Format

Status Word 0

15	14	13	12	11	10	09	08	07	06	05	04	03	02	01	00
Mode_Flag	Module_OK	Config_Err	Command_Err	Input_Err	Pos_Invalid	0	0	Move_Cmp	Decelerating	Accelerating	At_Home	Stopped	In_Hold_State	Moving_CCW	Moving_CW

Figure R6.4 Command Mode: Status Word 0 Format

- Bit 15: Mode_Flag** – Set to “1” if in Configuration Mode, and set to “0” if in Command Mode.
- Bit 14: Module_OK** – “1” when the SV Servo is operating without a fault, “0” when an internal fault condition exists.
- Bit 13: Configuration_Error** – “1” if a valid configuration does not exist in the memory of the SV Servo. “0” when the SV Servo has a valid configuration in memory.
- Bit 12: Command_Error** – Set under the following conditions:
 - An invalid command has been written to the SV Servo
 - Attempting to start a move while the motor is disabled
 - Disabling the motor while motion is occurring
 - Switching to Configuration Mode while the motor is enabled
 - Enabling the motor if the Profile and Encoder positions differ by greater than 4,096 counts when the Preset_On_Enable bit is not set.

This bit is reset by a *Reset Errors* command. The format of the command is given on page 73.
- Bit 11: Input_Error** – “1” when:
 - Emergency Stop input has been activated
 - Either of the End Limit Switches activates during any move operation except for homing
 - Starting a Jog Move in the same direction as an active End Limit Switch
 - If the opposite End Limit Switch is reached during a homing operation.

This bit is reset by a *Reset Errors* command. The format of the command is given on page 73.
- Bit 10: Position_Invalid** – “1” when:
 - An error is detected in the absolute encoder on power up
 - If the difference between the Profile Position and Encoder Position is greater than 4,096 counts when attempting to enable the motor.
 - If the difference between the Profile Position and Encoder Position exceeds the value of the Maximum Position Error Limit after a stall is detected and the SV Servo has come to a stop.
- Bits 9 & 8: Reserved** – Will always equal “0”.
- Bit 7: Move_Complete** – Set to “1” when the present Absolute, Relative, or Registration Move completes without error. This bit is reset to “0” when the next move command is written to the SV Servo, when the position is preset, or a Reset Errors command is issued to the unit. This bit is not set at the end of a jog move or a homing operation.

Input Data Format (continued)

Status Word 0 Format (continued)

- Bit 6: Decelerating** – Set to “1” when the present move is decelerating. Set to “0” at all other times.
- Bit 5: Accelerating** – Set to “1” when the present move is accelerating. Set to “0” at all other times.
- Bit 4: At_Home** – Set to “1” when a homing command has completed successfully, “0” at all other times.
- Bit 3: Stopped** – For normal moves, set to “1” when the motor is not in motion. Note that this is stopped for any reason, not just a completed move. For example, an Immediate Stop command during a move will set this bit to “1”, but the Move_Complete Bit, (bit 7 above) will not be set.

For Axis Follower Moves, the Stopped bit resets to “0” once the command is accepted and remains reset until the Axis Follower Move ends. The Moving_CW and Moving_CCW bit can be used to determine if motion is occurring during an Axis Follower Move.

- Bit 2: In_Hold_State** – Set to “1” when a move command has been successfully brought into a Hold State. Hold States are explained in the *Controlling Moves In Progress* section starting on page 40.
- Bit 1: Moving_CCW** – Set to “1” when the motor is rotating in a counter-clockwise direction.
- Bit 0: Moving_CW** – Set to “1” when the motor is rotating in a clockwise direction.

Status Word 1 Format

Status Word 1

15	14	13	12	11	10	09	08	07	06	05	04	03	02	01	00
Drive_Enabled	Stall_Detected	Cmd_Ack	Abs_Enc_Err	Heartbeat_Bit	Torque_Limit	Inv_Jog_Cng	STO_Failure	Driver_Fault	Connect_Lost	STO_Active	Temp_90°C	IN4_Active	IN3_Active	IN2_Active	IN1_Active

Figure R6.5 Command Mode: Status Word 1 Format

- Bit 15: Drive_Is_Enabled** – Set to “1” when the motor driver section of the SV Servo is enabled and current is available to the motor. Set to “0” when the motor driver section is disabled. If this bit is set to “1”, the motor current remains present when an E-Stop input is active.
- Bit 14: Stall_Detected** – Set to “1” when the difference between the commanded motor position and the encoder position exceeds the value of the Maximum Position Error Limit parameter. This parameter is set in the *Block 6: Position Control Loop Configuration Block* found on page 58.
- Bit 13: Command_Acknowledge** – Normally “0”. This bit is set to “1” when one of the following commands completes successfully:

- Preset Position
- Reset Errors

This bit resets to “0” when the command bit is reset to “0” by the host controller.

- Bit 12: Absolute Encoder Error** – This bit is set to “1” under the following conditions:
 - The shaft was subject to acceleration in excess of 160,000°/sec² (444.4 rev/sec²) while power was removed from the unit
 - The internal battery is fully discharged or damaged
 - The encoder itself is damaged

If this bit is set, cycle power to the unit. If the bit remains set, contact AMCI technical support for assistance.

Input Data Format (continued)**Status Word 1 Format (continued)**

- Bit 11: Heartbeat_Bit** – This bit will change state approximately every 500 milliseconds. Monitor this bit to verify that the unit and network connection are operating correctly. Note that this bit is only available while the SV Servo is in Command Mode.
- Bit 10: Torque_Limit** – This bit is set to ‘1’ when a torque limit is active during the move. In typical cases, this is the Peak Torque Limit during the acceleration and deceleration phases of the move and the Continuous Torque Limit during the constant speed phase of the move. If the Maximum Move Torque is set as part of the move command, this value is used through all of the phases of the move.
- Bit 9: Invalid_Jog_Change** – Set to ‘1’ during a Jog Move if parameters are changed to invalid values. The Jog Move continues with the old parameter values. This bit is reset to ‘0’ when the parameters are changed to valid values. Parameters that can be changed during a Jog Move are Programmed Speed, Acceleration, Deceleration, and Maximum Move Torque.
- Bit 8: STO_Failure** – This bit is only available on SV Servo units with the STO option. Reset to ‘0’ during normal operation, this bit is set to ‘1’ if the programmable STO Discrepancy Time Limit is exceeded. This indicates a failure in the normal operation of the STO circuit. This fault is non-clearable. Power must be cycled to the SV Servo to clear this fault.
- Bit 7: Driver_Fault** – This bit is set to “1” to indicate faults in the driver section of SV Servo, such as Over-temperature or Overcurrent Faults. If you are using an SV Servo unit with the STO option, this bit is set if either or both of the STO inputs are inactive. Driver Faults are self clearing. This bit will reset once the fault condition is removed.
- Bit 6: Connection_Was_Lost** – If the *physical* network connection is lost at any time, this bit will be set when the connection is re-established. This bit may also be set if a *protocol's* persistent network connection is lost. Note that the loss of a network connection on the protocol level cannot be detected on all platforms.
- Bit 5: STO_Active** – This bit is only available on SV Servo units with the STO option. Reset to ‘0’ during normal operation, this bit is set to ‘1’ if either or both of the STO Inputs become inactive. This bit indicates that the STO feature is active and power has been removed from the motor driver section. This bit automatically resets to ‘0’ when power is reapplied to both of the STO inputs. An Enable Driver command must be issued before power is restored to the motor. Note that issuing an Enable Driver command while this bit is active will result in a Command Error response. The data format of the *Enable Driver or Preset On Enable* command can be found on page 74.
- Bit 4: Temperature_Above_90°C** – This bit is set to “1” when the processor internal temperature exceeds 90°C. If this bit trips often and you want to lower the operating temperature of the unit, consider changing how the device is mounted, or installing a fan to force additional airflow over the device.
- Bit 3: IN4_Active** – “1” when Input 4 is in its active state. The active state of the input is programmed as explained in the *Block 2: I/O Configuration Block* section starting on page 54. If the unit has the STO option, this bit shows the state of the /STOB input.
- Bit 2: IN3_Active** – “1” when Input 3 is in its active state. The active state of the input is programmed as explained in the *Block 2: I/O Configuration Block* section starting on page 54. If the unit has the STO option, this bit shows the state of the /STOA input.
- Bit 1: IN2_Active** – “1” when Input 2 is in its active state. The active state of the input is programmed as explained in the *Block 2: I/O Configuration Block* section starting on page 54.
- Bit 0: IN1_Active** – “1” when Input 1 is in its active state. The active state of the input is programmed as explained in the *Block 2: I/O Configuration Block* section starting on page 54.

Notes on Clearing a Driver Fault

A Driver Fault occurs when there is an over temperature condition, or an over current condition. On SV Servo units with the STO option, a fault also occurs when one or both of the STO inputs are inactive. When a Driver Fault occurs, the SV Servo sets bit 7 of Status Word 1 in the Network Input Data. Bit 15 of Status Word 1, Drive_Is_Enabled, will also be reset to “0”, the driver will be disabled, and it will not supply current to the motor until the motor’s temperature decreases to a safe value. At this point the fault will clear itself and the drive can be re-enabled by a 0→1 transition on the Enable_Driver bit.

Notes

BRAKING RESISTOR CALCULATIONS

This reference introduces the calculations necessary to size an external braking resistor for your specific application.

Overvoltage Threshold Parameter

The Over Voltage Threshold parameter controls when the braking resistor is used. This parameter sets the tripping point on the power bus voltage. During a deceleration period, if the input power voltage exceeds this setpoint, the transistor on Ext. Brake Resistor pin turns on. (See page 27, *Power Connector*) The attached braking resistor becomes another load on the power bus during this time. The braking resistor absorbs the power that is generated during a deceleration period and prevents the power bus voltage from rising to the point where it can damage attached equipment. The Over Voltage Threshold parameter has the following ranges:

- If set to 0, the braking resistor is not used. The power bus voltage is not monitored and the Ext. Brake Resistor pin will never turn on.
- If set within the range of 550 to 1000, the braking resistor is used when the power bus voltage exceeds the set value. The value is programmed in steps of 0.1 V. The range of 550 to 1000 corresponds to a voltage range of 55.0 to 100.0 V

Required Information

Motor rated (continuous) power

- SV160E2: 157 W
- SV400E2: 400 W

Initial speed at the start of deceleration in radians/sec.

- Application specific. Maximum speed of the SV Servo is 3840 RPM. (402.1 radians/sec)
Speed in RPM \times 0.10472 = Speed in radians/sec.

Final speed at the end of deceleration in radians/sec.

- Application specific. Typical final speed is 0.
Speed in RPM \times 0.10472 = Speed in radians/sec.

Required deceleration time in seconds

- Application specific.

Motor Inertia in $\text{kg}\cdot\text{m}^2$

- SV160E2: $48 \times 10^{-6} \text{ kg}\cdot\text{m}^2$
- SV400E2: $29 \times 10^{-6} \text{ kg}\cdot\text{m}^2$

Load Inertia in $\text{kg}\cdot\text{m}^2$

- Application specific. Inertia in $\text{lb}\cdot\text{ft}^2 \times 4.214 \times 10^{-2} = \text{Inertia in } \text{kg}\cdot\text{m}^2$

Gear Ratio (GR) between motor and load

- $\text{GR} = \text{Load Speed} / \text{Motor Speed}$.

Programmed value for Overvoltage Threshold parameter

- This parameter sets the voltage at which the braking resistor circuit is turned on. Range of values is 55.0 to 100.0 volts with a 0.1 volt resolution.

Step 1: Determine Regenerative Power Capability

$$P_R = V_{ov} \times I_{max}$$

P_R = Maximum Regenerative Power Capability

V_{ov} = Programmed Overvoltage Threshold (55.0 to 100.0 Vdc)

I_{max} = Maximum Resistor Current (10 A for SV160E2. 15 A for SV400E2)

Step 2: Determine System Inertia

$$J_T = J_M + (GR^2 \times J_L)$$

J_T = Total System Inertia

J_M = Motor Inertia

GR = Gear Ratio

J_L = Load Inertia in kg·m²

It is suggested that the total reflected load inertia ($GR^2 \times J_L$) does not exceed 20 times the motor inertia.

Step 3: Determine the Deceleration Rate

$$\alpha_d = \frac{(\omega_i - \omega_o)}{T_d}$$

α_d = Deceleration in radians/sec²

ω_i = Initial Speed in radians/sec

ω_o = Final Speed in radians/sec

T_d = Time to decelerate

NOTE  The maximum deceleration rate is 6135.5 rad/sec². This is the programmable limit for the SV Servo units. If the calculated value exceeds this limit, the time to decelerate must be increased.

Step 4: Determine Peak Braking Power

$$P_b = \frac{J_T[\omega_i(\omega_i - \omega_o)]}{T_d}$$

P_b = Peak Braking Power in watts

J_T = Total System Inertia calculated in Step 1.

ω_i = Initial Speed in radians/sec

ω_o = Final Speed in radians/sec

T_d = Time to decelerate

**WARNING**

Peak Braking Power (P_b) cannot exceed the Regenerative Power Capability (P_R) calculated in step 1. Exceeding the Regenerative Power Capability may force the drive into current limit and cause a loss of motion control. If the calculated peak braking power exceeds this limit do one or more of the following:

- Increase the deceleration time
- Increase the Overvoltage Threshold Voltage used in step 1. Verify that the power supply for the SV Servo can safely operate with the higher overload voltage.
- Change the gear ratio to decrease the reflected load inertia.

Step 5: Determine Minimum Braking Resistor Value

$$R_{Bmin} = \frac{V_d}{I_{max}}$$

R_{Bmin} = Braking Resistor minimum value in ohms

V_d = Programmed Overvoltage Threshold (55.0 to 100.0 Vdc)

I_{max} = Maximum Resistor Current (10 A for SV160E2. 15 A for SV400E2)

**NOTE**

This is the minimum resistor value allowed in the circuit. Using a lower resistance value may damage the Braking Resistor circuit. The chosen resistor value must be between the minimum value determined in this step and the maximum value determined in step 6.

Step 6: Determine Maximum Braking Resistor Value

$$R_{Bmax} = \frac{(V_d)^2}{P_b}$$

R_{Bmax} = Braking Resistor maximum value in ohms

V_d = Programmed Overvoltage Threshold (55.0 to 100.0 Vdc)

P_b = Peak Braking Power calculated in Step 3.

**NOTE**

This is the maximum resistor value allowed in the circuit. Using a higher resistance value may cause an overvoltage error and loss of motion control during deceleration. The chosen resistor value must be between the minimum value determined in step 5 and the maximum value determined in this step.

Step 7: Determine Average Power Rating

To determine the average power dissipated by the braking resistor, you have to determine the peak power dissipated during each deceleration phase of your machine cycle, and the minimum cycle time of your machine.

$$P_{av} = \sum_1^n \left[\frac{T_{dn}}{T_c} \right] \frac{P_{bn}}{2} \left[\frac{(\omega_{in} + \omega_{on})}{\omega_{in}} \right]$$

T_{dn} = 'n'th deceleration time in seconds

T_c = Minimum machine cycle time in seconds

P_{bn} = Peak power rating during 'n'th deceleration period.

ω_{in} = Initial Speed in radians/sec during 'n'th deceleration period.

ω_{on} = Final Speed in radians/sec during 'n'th deceleration period.

Determining the Braking Resistor

- 1) The resistance value must be between the minimum resistance calculated in step 5 and the maximum resistance calculated in step 6.
- 2) The power rating of the resistor must be equal to or greater than the average power rating calculated in step 7.
- 3) The Braking Resistor must also be able to handle the peak power generated during deceleration. One option is to choose a resistor whose power rating is equal to the peak power calculated in step 4 instead of the average power calculated in step 7. The other option is to find the peak power rating for the resistor. Braking resistor manufacturers have two methods of defining the peak power a resistor can tolerate.
 - One method is to define peak power as a percentage of average power.
 - The other method is to define the energy the resistor can absorb, typically in joules. This calculation is $J = (P_b/2 \times T_d)$, where J is the energy in joules, P_b is the peak power during deceleration, and T_d is the time to decelerate.

CONFIGURING NETWORK INTERFACES

This section lists suggestions for configuring the network interfaces on your computer or laptop before attaching to an SV Servo unit.

Firewall Settings

Firewalls are hardware devices or software that prevent unwanted network connections from occurring. Firewall software has been present on Windows based computers since XP, and it may prevent your computer from communicating with the SV Servo. The internal webserver uses port 80, which is the default http port, and should work without changing any firewall settings. Configuring your firewall to allow communication with the SV Servo is beyond the scope of this manual.

Disable All Unused Network Interfaces

Routing and default gateway setting on your computer might prevent connection to the SV Servo. When using the Net Configurator utility, the broadcast packets that are used to find the SV Servo often go out the wrong interface. The easiest way to avoid this problem is to temporarily disable all network interfaces that are not attached to the SV Servo unit.

This includes all wireless interfaces as well as all Bluetooth interfaces.

Configure Your Network Interface

Before you can communicate with the SV Servo, your network interface must be on the same subnet as the device.

NOTE  The rest of this procedure assumes you are using the 192.168.0.xxx subnet. If you are not, you will have to adjust the given network addresses accordingly.

The easiest way to check the current settings for your NIC is with the 'ipconfig' command.

- For Windows 7, click on the [Start] button, and type "cmd" in the "Search programs and files" text box. Press [Enter] on the keyboard.
- For Windows 8 and 10, press the [Win+X] keys and select "Command Prompt" from the resulting popup. There is no need to run the command prompt as the administrator, so do not select "Command Prompt (Admin)".

Configure Your Network Interface (continued)

A DOS like terminal will open. Type in ‘ipconfig’, press [Enter] on the keyboard and the computer will return the present Address, Subnet Mask, and Default Gateway for all of your network interfaces. If your present address is 192.168.0.xxx, where ‘xxx’ does not equal 50, and your subnet mask is 255.255.255.0, then you are ready to configure your SV Servo unit. Figure R8.1 shows the output of an ipconfig command that shows the “Local Area Connection 2” interface on the 192.168.0.xxx subnet.

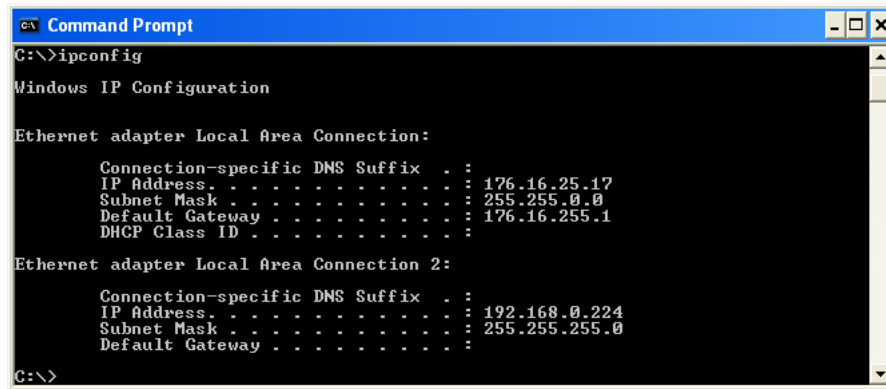

Figure R8.1 ipconfig Command

If your present address is not in the 192.168.0.xxx range, type in ‘ncpa.cpl’ at the command prompt and hit [Enter] on the keyboard.

For Windows 7+, this will open the *Network Connections* window. Right click on the appropriate interface and select “Properties”. In the window that opens, select “Internet Protocol Version 4 (TCP/IP v4)” from the list and then click on the [Properties] button.

Set the address and subnet mask to appropriate values. (192.168.0.1 and 255.255.255.0 will work for an SV Servo that has factory default settings.) The default gateway and DNS server settings can be ignored.

Test Your Network Interface

Going back to the terminal you opened in the last step, type in ‘ping aaa.bbb.ccc.ddd’ where ‘aaa.bbb.ccc.ddd’ is the IP address of the SV Servo. The computer will ping the unit and the message “Reply from aaa.bbb.ccc.ddd: bytes=32 time<10ms TTL=128” should appear four times.

If the message “Request timed out.” or “Destination host unreachable” appears, then one of four things has occurred:

- You set a new IP address, but have not yet cycled power to the SV Servo
- You did not enter the correct address in the ping command.
- The IP address of the SV Servo is not set correctly.
- The SV Servo and the computer are not on the same subnet.

TASK 1

INSTALLING AN SV SERVO

1.1 Location

SV Servo units are IP50 rated and are suitable for use in industrial environments that meet the following criteria:

- ▶ Only non-conductive pollutants normally exist in the environment, but an occasional temporary conductive caused by condensation is to be expected.
- ▶ Transient voltages are controlled and do not exceed the impulse voltage capability of the product's insulation.

These criteria are equivalent to the *Pollution Degree 2* and *Over Voltage Category II* designations of the International Electrotechnical Commission (IEC).

1.2 Safe Handling Guidelines

1.2.1 Prevent Electrostatic Damage



Electrostatic discharge can damage the SV Servo. Follow these guidelines when handling the unit.

- 1) Touch a grounded object to discharge static potential before handling the unit.
- 2) Work in a static-safe environment whenever possible.
- 3) Wear an approved wrist-strap grounding device.
- 4) Do not touch the pins of the network connectors or I/O connector.
- 5) Do not disassemble the unit
- 6) Store the unit in its shipping box when it is not in use.

1.2.2 Prevent Debris From Entering the Unit



While mounting devices, be sure that all debris (metal chips, wire strands, tapping liquids, etc.) is prevented from falling into the unit, specifically into the M12 connectors. Debris may cause damage to the unit or unintended machine operation with possible personal injury.

1.2.3 Remove Power Before Servicing



Remove power before removing or installing any SV Servo unit.

1.3 Operating Temperature Guidelines

Due to the onboard electronics, the maximum operating temperature of the SV Servo is limited to 203°F/95°C. The motor by itself has a maximum operating temperature of 266°F/130°C. Depending on the operating current setting, move profiles, and idle time, it is possible to exceed these temperatures in a thermally isolated environment. As explained in the mounting section, mounting the SV Servo to a large metal heatsink is the best way to limit the operating temperature of the device. Operating temperature should be monitored during system startup to verify that the maximum motor temperature remains below its 203°F/95°C specification. SV Servo devices have an onboard thermistor that monitors the temperature of the electronics and will remove motor current if their operating temperature reaches this limit. These overtemperature faults are also reported in the Network Input Data.

1.4 STO General Installation Guidelines

1.4.1 Qualified Personnel

Every person that uses AMCI products in safety systems must have proven skills and training to:

- Design
- Assemble
- Install
- Program
- Document
- Commission
- Maintain
- Decommission

Persons with proven skills and training:

- Are qualified engineers in applicable fields
- Are people who have been trained by qualified engineers
- Know the applicable regulations about safety and accident prevention for the specific project
- Can preform hazard and risk analysis for the project
- Can identify safety functions and assign appropriate SIL or PLr values to these functions
- Can design appropriate interfaces to other subsystems in the project.
- Have read and understand the information contained in the applicable sections of this manual.

1.4.2 Remain Within the Environmental Limits

A safety system may not function correctly if the unit is operated outside of its environmental limits. Environmental limits are published in the *Specifications* section of the manual.

1.4.3 Properly Use Inputs STOA and STOB

Both safety inputs must be used when you install an SV160E2-STO and use the STO feature. You shall not bypass one of the inputs. Both inputs must be connected to appropriate safety devices when the STO feature is used.

1.4.4 Consulting Services

AMCI does not provide design or consulting services. AMCI cannot advise whether or not the use of our products would ensure compliance with the safety requirements for any application.

Any person or company using products sold by AMCI is solely responsible for a safety design that meets all of the requirements of their system. Any person or company using products sold by AMCI assumes all risks, and accepts full responsibility for their use and suitability in the application.

1.5 Mounting an SV Servo

All AMCI motors have flanges on the front of the motor for mounting. This flange also acts as a heatsink, so motors should be mounted on a large, unpainted metal surface. Mounting a motor in this fashion will allow a significant amount of heat to be dissipated away from the motor, which will increase the unit's life by reducing its operating temperature.

1.5 Mounting an SV Servo (continued)

Motors should be mounted using hardened 5mm or #10 hardware. AMCI motors can produce high torques and accelerations that may weaken and shear inadequate mounting hardware.



The motor case must be grounded for proper operation. This is usually accomplished through its mounting hardware. If you suspect a problem with your installation, such as mounting the motor to a painted surface, then run a bonding wire from the motor to a solid earth ground point near it. Use a minimum #8 gauge stranded wire or 1/2" wire braid as the grounding wire

1.5.1 SV160E2 Outline Drawing

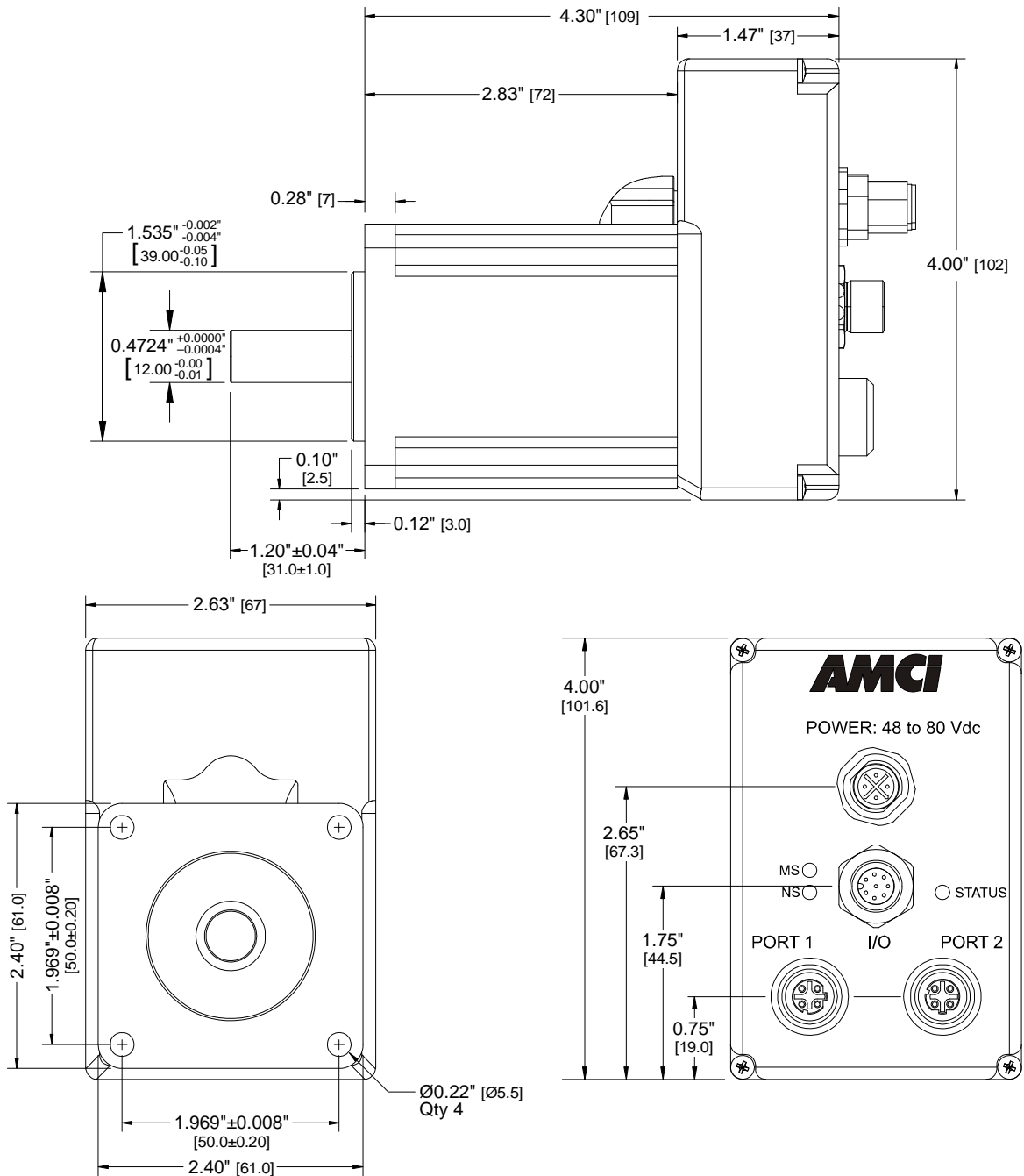

Figure T1.1 SV160E2 Outline Drawing

1.5 Mounting an SV Servo (continued)

1.5.2 SV400E2 Outline Drawing

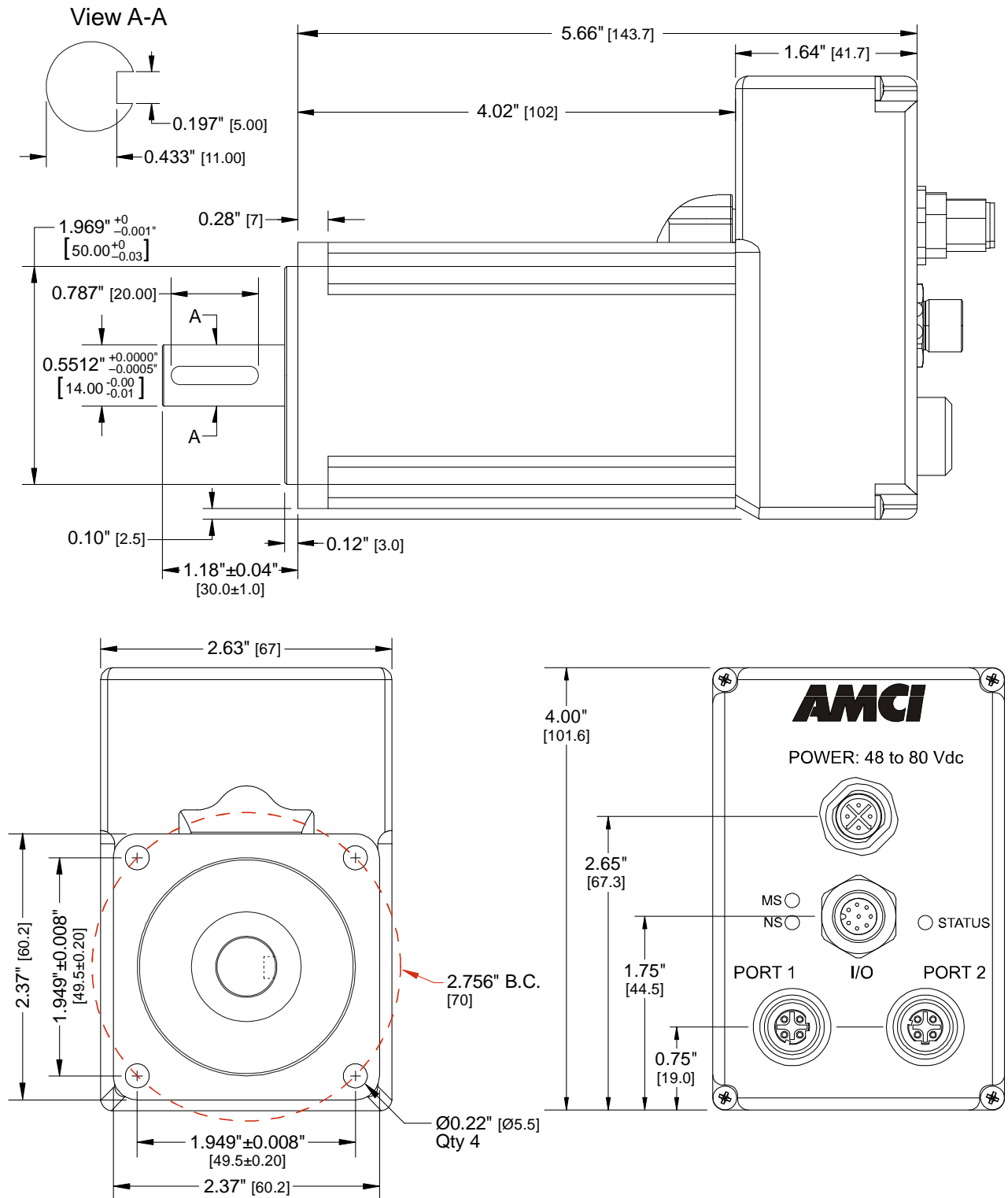

Figure T1.2 SV400E2 Outline Drawing

1.5 SV Servo Mounting (continued)

1.5.3 SV Servo Mounting

The SV Servo is not water tight. Its IP50 rating makes it acceptable for use in dusty environments with occasional condensation. Units should be mounted in such a way that condensation will naturally drain off of the unit instead of pooling at the motor shaft, where the motor wires exit the motor, or on the motor laminations.

1.5.4 Connecting the Load

Care must be exercised when connecting your load to the SV Servo. Even small shaft misalignments can cause large loading effects on the bearings of the motor and load. The use of a flexible coupler is *strongly* recommended whenever possible.

- Maximum radial load is 45 lbs. (200N) at the end of the shaft.
- Maximum axial load is 13.5 lbs. (60N)

NOTE  Internal encoders are mounted on the end of the motor shaft that is internal to the unit. Excessive axial load may cause encoder mis-alignment and damage to the unit. This type of damage is not covered under warranty.

1.6 Mounting an SV Servo with Brake Option

All AMCI motor brakes have flanges on the front for mounting. This flange also acts as a heatsink, so units should be mounted on a large, unpainted metal surface. Mounting in this fashion will allow a significant amount of heat to be dissipated away from the motor, which will increase the unit's life by reducing its operating temperature.

Motor/brake combinations should be mounted using hardened 5mm or #10 hardware. AMCI motors can produce high torques and accelerations that may weaken and shear inadequate mounting hardware.

NOTE  The motor case must be grounded for proper operation. This is usually accomplished through its mounting hardware. If you suspect a problem with your installation, such as mounting the motor to a painted surface, then run a bonding wire from the motor to a solid earth ground point near it. Use a minimum #8 gauge stranded wire or 1/2" wire braid as the grounding wire

1.6 Mounting an SV Servo with Brake Option (continued)

1.6.1 SV160E2-B Outline Drawing

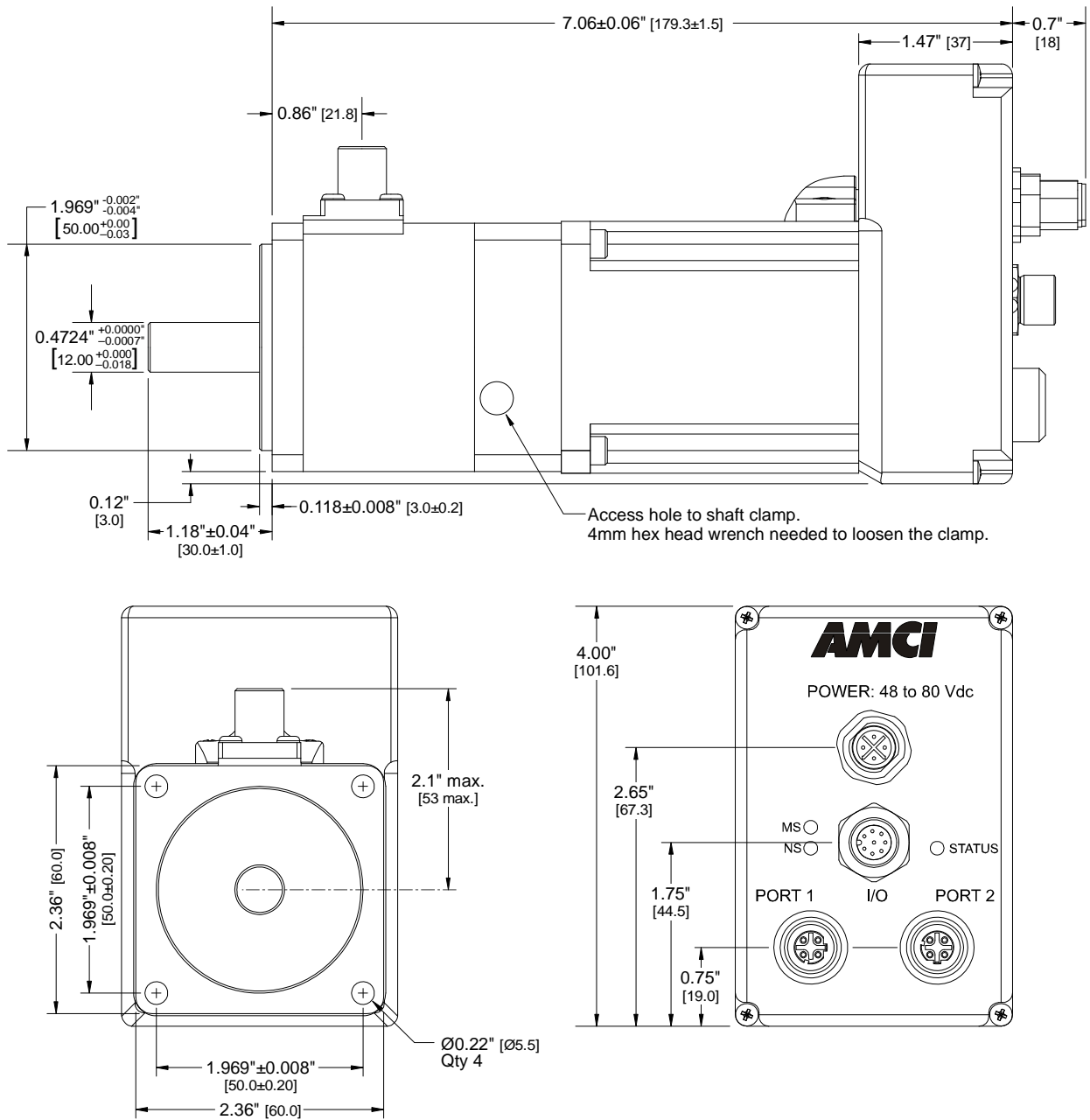

Figure T1.3 SV160E2-B Outline Drawing

1.6 Mounting an SV Servo with Brake Option (continued)

1.6.2 SV400E2-B Outline Drawing

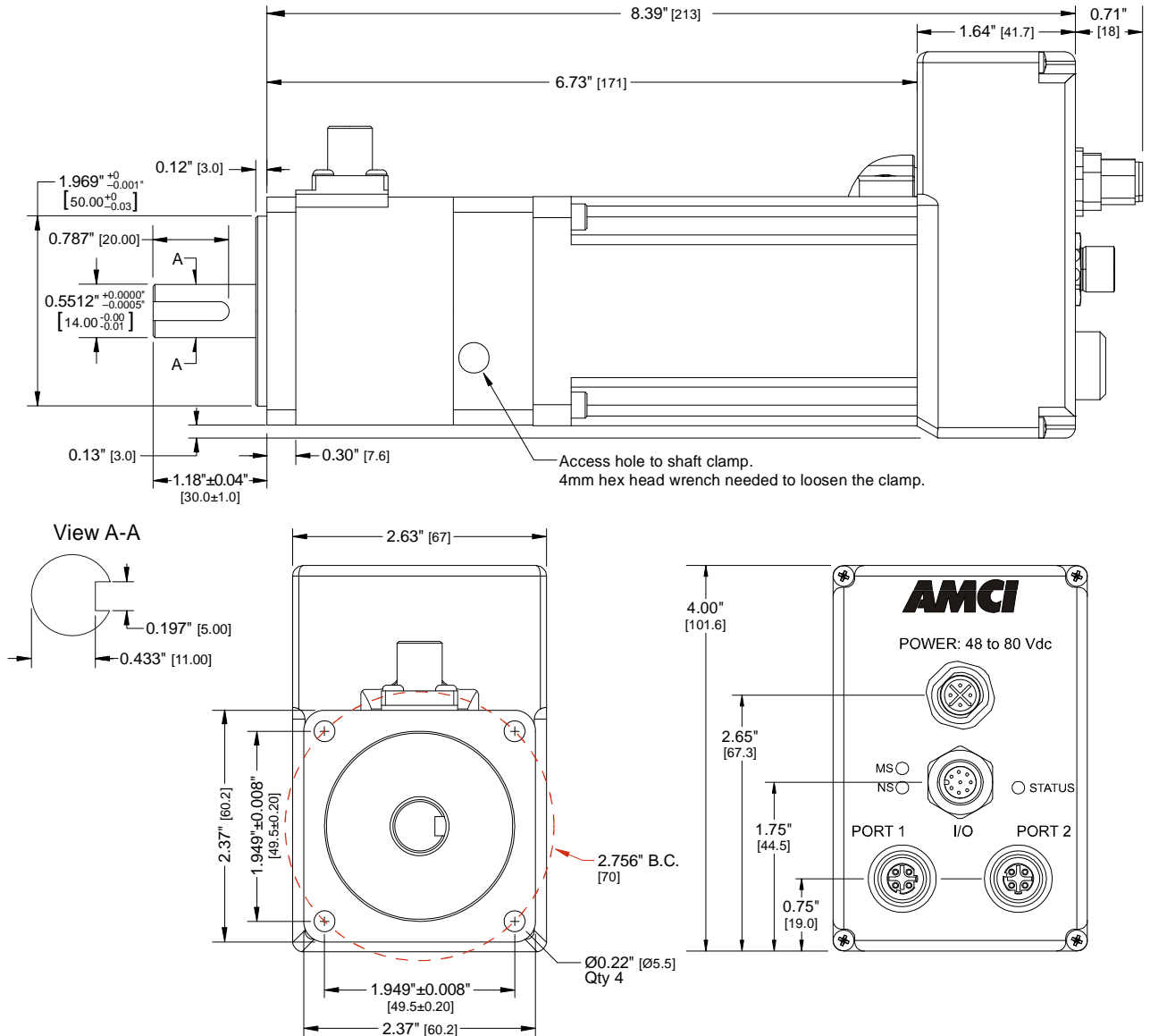

Figure T1.4 SV400E2-B Outline Drawing

1.6.3 SV160E2-B/SV400E2-B Mounting

The SV Servo with the brake option is not water tight. Its IP50 rating makes it acceptable for use in dusty environments with occasional condensation. Units should be mounted in such a way that condensation will naturally drain off of the unit instead of pooling at the motor shaft, where the motor wires exit the motor, on the motor laminations, or the access hole to the brake's shaft clamp.

1.6 Mounting an SV Servo with Brake Option (continued)

1.6.4 Connecting the Load

Care must be exercised when connecting your load to the SV Servo with the brake option. Even small shaft misalignments can cause large loading effects on the bearings of the motor and load. The use of a flexible coupler is *strongly* recommended whenever possible.

- Maximum radial load is 45 lbs. (200N) at the end of the shaft.
- Maximum axial load is 13.5 lbs. (60N)

NOTE ⚠ Internal encoders are mounted on the end of the motor shaft that is internal to the unit. Excessive axial load may cause encoder mis-alignment and damage to the unit. This type of damage is not covered under warranty.

1.7 Power Connector

Figure T1.5 shows the power connector pinout when viewed from the back of the SV Servo. The connector is a male, four pin, S-coded, M12 connector that is IP67 rated when its mate is properly installed.

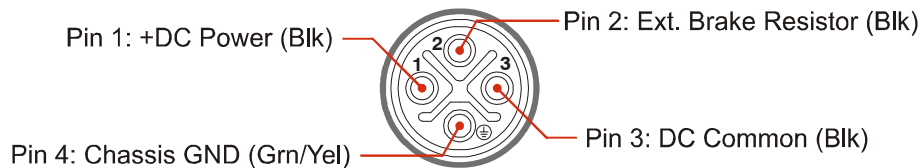
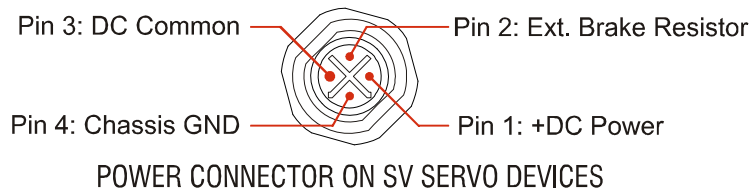

Figure T1.5 Power Connector Pinout

+DC Power and DC Common are used to power the SV Servo. The Ext. Brake Resistor pin is for an external regeneration resistor to limit power dissipation during deceleration. The Chassis GND pin should be used to ground the chassis of the motor if it is not grounded through its mounting.

NOTE ⚠ The SV Servo can be run at voltages as high as 80 Vdc, and uses an S-coded connector because of this high voltage. Most S-coded cordsets have three black wires and a single green/yellow wire. When using such a cable with an SV Servo, it is strongly recommended to label the wires by pin number before installing the cordset.

1.7 Power Connector (continued)

1.7.1 Compatible Connectors and Cordsets

Many different connectors and cordsets are available on the market, all of which will work with the SV Servo provided that the manufacturer follows the M12 connector standards. AMCI offers the following mating connector and cordset that mate with the power connector.

AMCI #	Description
MS-41	Mating connector for Power Connector. Female, 4 pin, S-coded. Screw terminal connections. 16AWG conductor, 8 to 10 mm dia. cable. Right-angle, IP67 rated when properly installed.
CNGL-5M	4-position, 1.5 mm ² (16 AWG) wire. Connector: Straight M12, S-coded, Female to flying leads, 0.28" stripped. Cable length: 5 m

Table T1.1 Compatible Power Connectors and Cordsets

1.8 Power Wiring

The SV Servo accepts 48 to 80 Vdc as its input power. AMCI strongly suggests using 16 AWG wire for the power connections. The MS-41 connector will accept up to 16 gauge wire and the CNGL-5M cordset is built with 16 gauge wire.



Do not apply 120 Vac to any pins of the SV Servo. If this occurs, the unit will be damaged and you will void the unit's warranty.

Figure T1.6 below shows how to wire power to the SV Servo units. The figure below shows how to wire a CNGL-5M cable to a power supply.



The chassis ground connection is optional for most installations, but must be used if the SV Servo is not properly ground through its mounting.

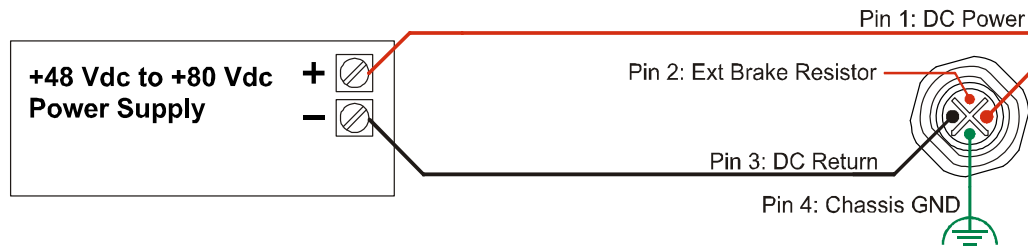

Figure T1.6 SV Servo Power Wiring

1.9 Input Connector

All input connections are made at the Input Connector. This connector is a standard eight pin A-coded M12 connector that is rated to IP67 when the mate is properly installed. Figure T1.7 shows the pinout for the Input Connector when viewed from the back of the unit.

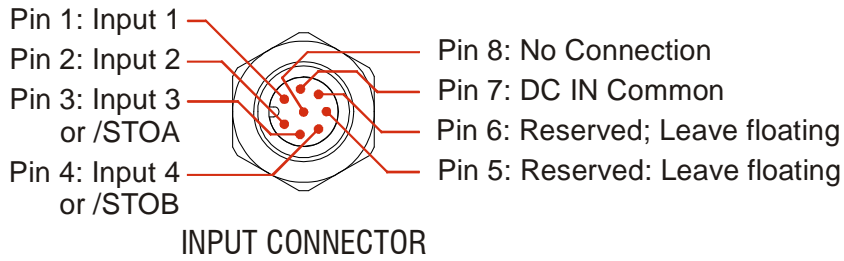

Figure T1.7 Digital Input Connector

All four digital inputs are single ended, sinking inputs that share a common DC reference, (Pin 7, DC IN Common).

All of the inputs accept a nominal 12 Vdc to 24 Vdc signal without the need of a current limiting resistor. Additional information on how the digital inputs can be used can be found in the [Available Discrete Inputs](#) section, starting on page 17.

1.9.1 Compatible Connectors and Cordsets

Many different connectors and cordsets are available on the market, all of which will work with the SV Servo provided that the manufacturer follows the A-coded M12 standards. The following connector and cordset is available from AMCI.

AMCI #	Description
MS-37	Mating connector for Input Connector. Female, 8 pin A-coded. Screw terminal connections. 6 to 8 mm dia. cable. Straight, IP67 rated when properly installed.
CNFL-5M	8-position, 24 AWG. Connector: Straight M12, A-coded, Female to 2 inch flying leads, 0.28" stripped. Cable length: 5 m

Table T1.2 Compatible Digital Input Connectors and Cordsets

1.9 Input Connector (continued)

1.9.2 CNFL-5M Color Code and Shield Wire

The following diagram shows the color code of the CNFL-5M as well as connection between the cable shield and the connector.



The shield wire on the CNFL-5M is connected to the metal body of the connector. Therefore, the shield wire of the CNFL-5M is connected to chassis ground through the SV Servo. You must exercise caution when connecting shielded cable to the CNFL-5M to avoid ground loops.

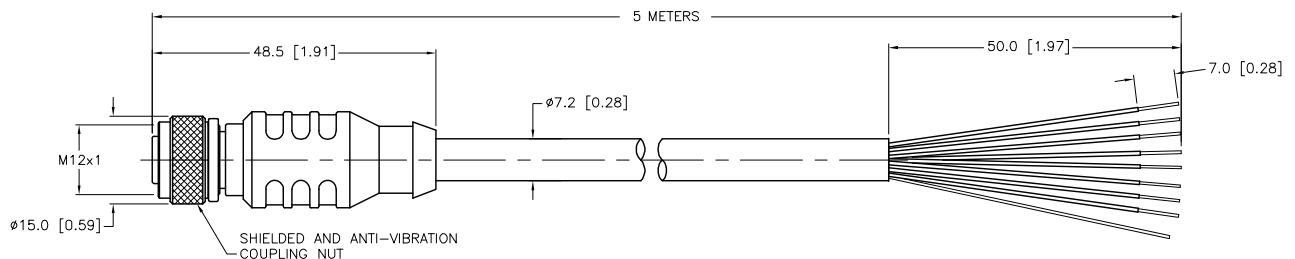

Pin	Description	Color
1	Input 1	White
2	Input 2	Brown
3	Input 3 (or STOA)	Green
4	Input 4 (or STOB)	Yellow

Pin	Description	Color
5	Reserved - Do not connect. Leave floating.	Gray
6	Reserved - Do not connect. Leave floating.	Pink
7	IN DC Common	Blue
8	No Connection	Red

Figure T1.8 CNFL-5M Cable

1.9.3 Cable Shields

Because they are low power signals, cabling from the sensor to the SV Servo should be done using a cable that has an overall shield. The shield should be grounded at the end when the signal is generated, which is the sensor end. If this is not practical, the shield should be grounded to the same ground bus as the SV Servo.



The shield wire on the CNFL-5M is connected to the metal body of the connector. Therefore, the shield wire of the CNFL-5M is connected to chassis ground through the SV Servo. You must exercise caution when connecting shielded cable to the CNFL-5M to avoid ground loops.

1.10 DC Input Wiring

Refer to section 1.11, *STO Input Wiring*, for information on wiring the STO inputs of an SV160E2-STO or SV400E2-STO.

Inputs 1 through 4 on the SV Servo units and inputs 1 and 2 on the SV Servo units with the STO option are single ended inputs that share the DC Common return pin. They accept a nominal 12 to 24 Vdc signal without the need for an external current limiting resistor. If using 48 Vdc sensors, a 5 kilohm resistor that is wired in series with the input pin is required. Figure T1.10 below shows how to wire discrete DC sourcing and sinking sensors to the DC inputs of the SV Servo. Colors in parentheses are the appropriate wire color of the CNFL-5M cable.

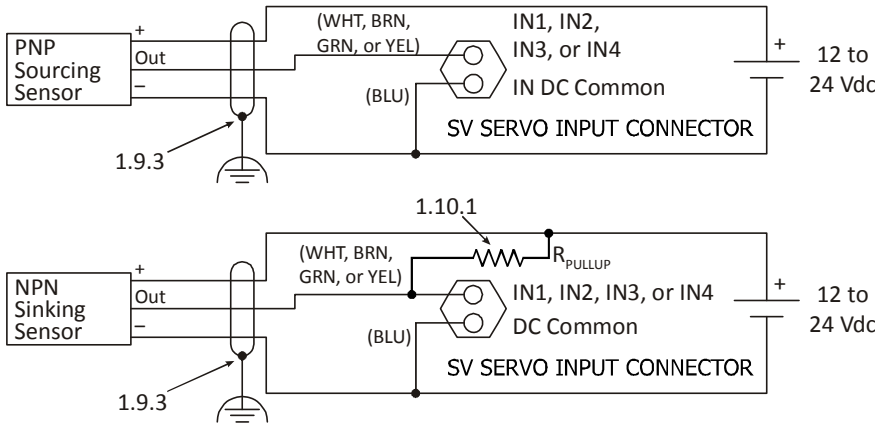

Figure T1.10 Wiring - Digital Inputs 1 through 4

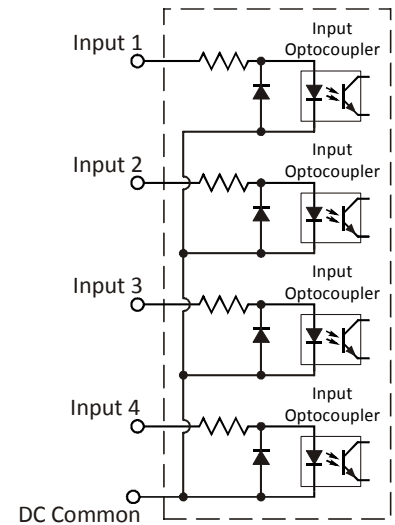

Figure T1.9 Schematic - Inputs 1 - 4

1.10.1 Sinking Sensors Require a Pull Up Resistor

Sensors with sinking outputs require an external pull up resistor because the digital inputs of the SV Servo units also sink current. Table T1.1 below shows the values of pull up resistors that will allow the unit's input to activate along with the current that the sensor must be able to sink when it is active.

Input Voltage	Pull Up Resistor	Sensor Current When Active
12 Vdc	1.4 kilohm	8.6 mA
24 Vdc	3.8 kilohm	6.3 mA

Table T1.3 Pull Up Resistor Values for DC Inputs

The logical states of the sensor and SV Servo input will be reversed. The SV Servo input is off when the sensor is active. You can set the logic state of the input when you configure the unit.

1.11 STO Input Wiring

Units with the STO option use Inputs 3 and 4 as the redundant STO inputs. These inputs must have 12 to 24 Vdc applied to them before the motor’s power stage is enabled. If you have a unit with the STO option and are not using the STO option, then you must apply 12 to 24Vdc to both inputs to bypass the STO functionality. Colors in parentheses are the appropriate wire color for the CNFL-5M cable.

Connections to bypass STO Inputs

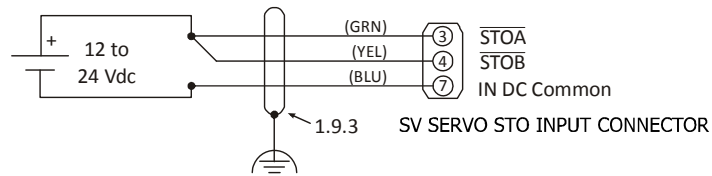

Minimum Connections to STO Inputs

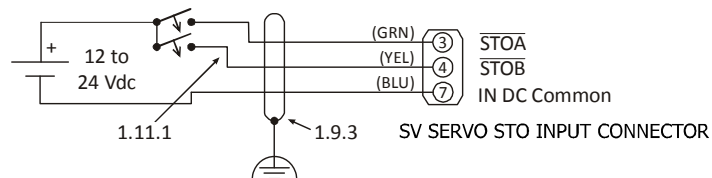

Figure T1.11 STO Input Connections

1.11.1 Extending the STO Cabling

The STO inputs are fast acting, and therefore susceptible to electrical noise. Keep the cabling from the safety relay to the SV Servo as short as possible. If you have to extend the cabling beyond a CNFL-5M, use shielded twisted pair cabling. The second wire of the pair should be connected to the power supply return.

1.12 SV Servo Brake Connector

Figure T1.5 shows the brake connector pinout when viewed from the top of an SV Servo unit with the brake option. The connector is a male, two pin, A-coded, M12 connector that is IP67 rated when its mate is properly installed.

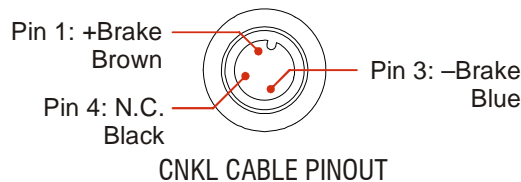
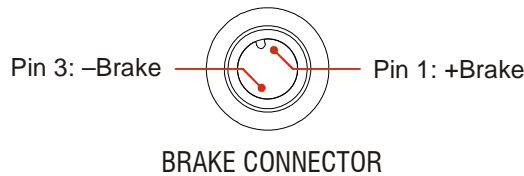

Figure T1.12 M12 Brake Connector Pinout

Twenty-four volt power must be applied to the brake inputs in order to release the brake. A system power failure will engage the brake.

1.12 SV Servo Brake Connector (continued)

1.12.1 Compatible Cordsets and Connectors

A one meter cable with a right angle connector is supplied with the brake option. If a longer cable is needed, many different connectors and cordsets are available on the market, all of which will work with the SV Servo provided that the manufacturer follows the M12 connector standards. AMCI offers the following cordsets that mate with the brake connector.

AMCI #	Description
CNKL-2M	3-position, 0.34 mm ² (22 AWG) wire. Connector: Right angle M12, A-coded, Female to flying leads, 0.28" stripped. Cable length: 2 m (6.5 feet)
CNKL-5M	3-position, 0.34 mm ² (22 AWG) wire. Connector: Right angle M12, A-coded, Female to flying leads, 0.28" stripped. Cable length: 5 m (16.4 feet)

Table T1.4 Compatible Brake Cordsets

The following is a compatible connector sold by Binder.

Binder #	Description
99-0430-27-04	Female, 3 pin A-coded. Screw terminal connections. 0.75 mm ² (18 AWG) maximum wire size. 4 to 6 mm (0.185" to 0.236") dia. cable. Right angle, IP67 rated when properly installed.

Table T1.5 Compatible Brake Connector

1.13 Brake Wiring

The brake option accepts 24 Vdc as its input power. The brake coil has a resistance of 52 ohms. It requires a minimum of 22 Vdc @ 425 mA to release.

Figure T1.13 below shows how to wire power to the brake of an SV Servo. The CNKL cable is shown as a reference. Note that the CNKL cables have a black wire on the third pin that is not used in this application. The wire is isolated at the connector, so it is safe to attach the wire to -Brake or leave it floating.

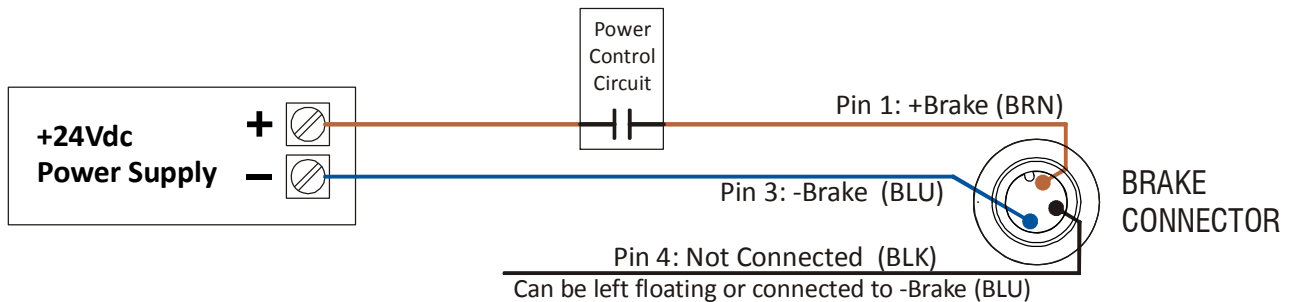

Figure T1.13 Brake Input Wiring

1.14 Network Connectors

Figure T1.14 shows the Ethernet connector pinout when viewed from the back of the SV Servo. The Ethernet ports on the units are “auto-sense” ports that will automatically switch between 10baseT and 100baseT depending on the network equipment they are attached to. Both ports also have the auto MDI-X capability. This means that a standard cable can be used when connecting an SV Servo to any device, including a personal computer.

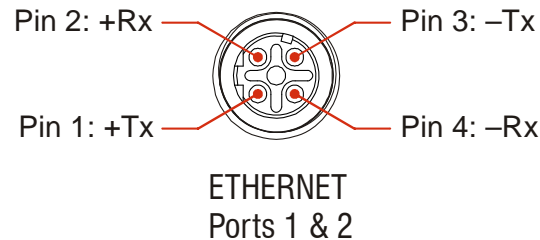

Figure T1.14 M12 Ethernet Connector Pinout

The connector is a standard female four pin D-coded M12 connector that is rated to IP67 when the mate is properly attached.

The SV Servo units have two ethernet ports. In non-redundant network applications, either port can be used to attach the SV Servo to the network.

1.14.1 Compatible Connectors and Cordsets

Many different connectors and cordsets are available on the market, all of which will work with the SV Servo provided that the manufacturer follows the connector and Ethernet standards. AMCI offers the following mating connector and cordsets that mate with the Ethernet port connectors.

AMCI #	Description
MS-28	Mating connector for Ethernet port connector. Screw terminal connections. 6 to 8 mm dia. cable. Straight, IP67 rated when properly installed.
CNER-5M	Molded cordset for Ethernet connector. 5 meters in length. Straight M12 4 pin D-coded to RJ-45 connector. Wired to TIA/EIA-568B. IP67 rated when properly installed.

Table T1.6 Compatible Ethernet Connectors and Cordsets

1.14.2 TIA/EIA-568 Color Codes

There are two color codes in common use when wiring Ethernet connections with twisted pairs. Either one of these standards is acceptable. The CNER-5M cable available from AMCI follows the 568B standard. Note that accidentally reversing the Tx/Rx pairs will not affect the operation of the SV Servo. The ethernet ports on the SV Servo have the auto MDI-X capability that will automatically adjust for swapped pairs.

Signal	568A Color	568B Color
+Transmit (+Tx)	White/Green Tracer	White/Orange Tracer
-Transmit (-Tx)	Solid Green	Solid Orange
+Receive (+Rx)	White/Orange Tracer	White/Green Tracer
-Receive (-Rx)	Solid Orange	Solid Green

Table T1.7 TIA/EIA Color Codes

1.15 EtherNet/IP Connections

1.15.1 Non-DLR Applications

The SV Servo unit has two Ethernet ports with a built-in Ethernet switch connecting the two. In non-DLR applications, either port can be used to attach the unit to the network. The remaining port can be used to extend the network to another device if this would reduce wiring costs.

1.15.2 DLR Applications

In Device Level Ring applications, the SV Servo unit functions as Beacon-Based Ring Nodes. In these applications, both ports are used when wiring the ring, daisy chaining from one unit in the ring to the next.

1.16 PROFINET Connections

1.16.1 Non-MRP Applications

The SV Servo unit has two Ethernet ports with a built-in Ethernet switch connecting the two. In non-MRP applications, either port can be used to attach the unit to the network. The remaining port can be used to extend the network to another device if this would reduce wiring costs.

1.16.2 MRP Applications

In Media Redundancy Protocol applications, the SV Servo unit functions as a Media Redundancy Client (MRC). In these applications, both ports are used when wiring the ring, daisy chaining from one unit in the ring to the next.

1.17 Modbus TCP Connections

The SV Servo unit has two Ethernet ports with a built-in Ethernet switch connecting the two. Either port can be used to attach the unit to the network. The remaining port can be used to extend the network to another device if this reduces wiring costs.

1.18 STO Commissioning

1.18.1 When to run the tests

The STO function must be tested before the first operation of the machine. The STO function must be tested after each change to the machine that involves the STO function. Some PL and SIL safety levels also require tests at defined intervals. Qualified personnel must define the interval of time between safety tests before the machine is commissioned.

1.18.2 Basic commissioning test outline

This basic commissioning test outline covers the functionality of the STOA and STOB inputs only. It does not verify the operation of the monitoring software available on the unit.

NOTE  The steps below are an outline of the test. A qualified person, or persons, must design and document the actual commissioning test for the machine. Both inputs must be tested.

- 1) Enable the motor
- 2) Run the motor at a predefined velocity
- 3) Remove power from STO Channel A (Input 3)
- 4) Make sure that the motor coasts to a stop.
- 5) Apply power to STO Channel A (Input 3).
- 6) Make sure that the motor remains stopped.
- 7) Enable the motor through a command over the network.
- 8) Run the motor at a predefined velocity.
- 9) Verify the motor is at the correct velocity.
- 10) Repeat steps 3 through 9 using STO Channel B (Input 4).

NOTE  The actual commissioning test will continue from here. The qualified person who writes the test must decide what steps to perform from here.

1.18.3 Commissioning test outline - Discrepancy Timer Limit = 0

NOTE  The steps below are an outline of the test. A qualified person, or persons, must design and document the actual commissioning test for the machine. Both inputs must be tested.

- 1) Enable the motor
- 2) Run the motor at a predefined velocity
- 3) Remove power from STO Channel A (Input 3)
- 4) Make sure that:
 - 4a) The motor coasts to a stop.
 - 4b) These values are in the network input data:
 - 4b.1) Word 1, bit 2: IN3_Active = 0
 - 4b.2) Word 1, bit 3: IN4_Active = 1
 - 4b.3) Word 1, bit 5: STO_Active = 1
 - 4b.4) Word 1, bit 7: Driver_Fault = 1
 - 4b.5) Word 1, bit 8: STO_Failure = 0
- 5) Apply power to STO Channel A (Input 3)

Continued on next page...

1.18 STO Commissioning

1.18.3 Commissioning test outline - Discrepancy Timer Limit = 0 (continued)

- 6) Make sure that:
 - 6a) The motor remains stopped.
 - 6b) These values are in the network input data:
 - 6b.1) Word 1, bit 2: IN3_Active = 1
 - 6b.2) Word 1, bit 3: IN4_Active = 1
 - 6b.3) Word 1, bit 5: STO_Active = 0
 - 6b.4) Word 1, bit 7: Driver_Fault = 0
 - 6b.5) Word 1, bit 8: STO_Failure = 0
- 7) Enable the motor through a command over the network.
- 8) Run the motor at a predefined velocity.
- 9) Verify that the motor is at the correct velocity.
- 10) Repeat steps 3 through 6 using STO Channel B (Input 4).
 Note that in step 4b.1, IN3_Active = 1 and in step 4b.2, IN4_Active = 0.

NOTE  The actual commissioning test will continue from here. The qualified person who writes the test must decide what steps to perform from here.

1.18.4 Commissioning test outline - Discrepancy Timer Limit Not Equal to Zero.

NOTE  The steps below are an outline of the test. A qualified person, or persons, must design and document the actual commissioning test for the machine. Both inputs must be tested.

- 1) Enable the motor through a command over the network.
- 2) Run the motor at a predefined velocity
- 3) Verify that the motor is at the correct velocity.
- 4) Remove power from STO Channel A (Input 3)
- 5) Make sure that:
 - 5a) The motor coasts to a stop.
 - 5b) These values are in the network input data:
 - 5b.1) Word 1, bit 2: IN3_Active = 0
 - 5b.2) Word 1, bit 3: IN4_Active = 1
 - 5b.3) Word 1, bit 5: STO_Active = 1
 - 5b.4) Word 1, bit 7: Driver_Fault = 1
- 6) If needed, wait for the time defined by the Discrepancy Timer Limit to pass. Make sure that input word 1, bit 8: STO_Failure equals 1.
- 7) Apply power to STO Channel A (Input 3)
- 8) Make sure that:
 - 8a) The motor remains stopped.
 - 8b) These values are in the network input data:
 - 8b.1) Word 1, bit 2: IN3_Active = 1
 - 8b.2) Word 1, bit 3: IN4_Active = 1
 - 8b.3) Word 1, bit 5: STO_Active = 0
 - 8b.4) Word 1, bit 7: Driver_Fault = 0
- 9) Cycle power to the SV Servo.
 - 9a) Remove power from the SV Servo.
 - 9b) Wait for the NS and MS LEDs on the unit to turn off.
 - 9c) Apply power to the SV Servo.
 - 9d) Wait for it to connect to the network.
- 10) Repeat steps 1 through 9 but use STO Channel B (Input 4) in steps 4 and 7.
 Note that in step 5b.1, IN3_Active = 1 and in step 5b.2, IN4_Active = 0.

Continued on next page...

1.18 STO Commissioning (continued)

1.18.4 Commissioning test outline - Discrepancy Timer Limit Not Equal to Zero. (continued)

- 11) Enable the motor through a command over the network.
- 12) Run the motor at a predefined velocity
- 13) Verify that the motor is at the correct velocity.
- 14) Remove power from both inputs at the same time.
- 15) Make sure that the motor comes to a coasting stop.
- 16) Wait for the time defined by the Discrepancy Timer Limit parameter to pass.
- 17) Make sure that input word 1, bit 8: STO_Failure equals 0.
- 18) Apply power to STO Channel A (Input 3)
- 19) Wait for the time defined by the Discrepancy Timer Limit parameter to pass.
- 20) Make sure that input word 1, bit 8: STO_Failure equals 1.
- 21) Apply power to STO Channel B (Input 4)
- 22) Cycle power to the SV Servo.
 - 9a) Remove power from the SV Servo.
 - 9b) Wait for the NS and MS LEDs on the unit to turn off.
 - 9c) Apply power to the SV Servo.
 - 9d) Wait for it to connect to the network.
- 23) Make sure that input word 1, bit 8: STO_Failure equals 0.
- 24) Repeat steps 11 through 23, but apply power to STO Channel B (Input 4) in step 18 and STO Channel A (Input 3) in step 21.

NOTE  The actual commissioning test will continue from here. The qualified person who writes the test must decide what steps to perform from here.

Notes

TASK 2

SET THE IP ADDRESS AND PROTOCOL

This section is intended for the engineer or technician responsible for setting the IP address of an AMCI SV Servo unit.

2.1 Determine the Best Method for Setting the IP Address

There are three methods for setting the IP address on an SV Servo. Table T2.1 below outlines the available methods and when you can use them.

Method	Restrictions	Section
<i>Use Factory Default Settings</i>	1) The machine must use 192.168.0.xxx subnet. 2) The 192.168.0.50 address must be available.	2.2a
<i>Use the Embedded Web Server</i>	No restrictions on use. This is the preferred method. The internal webserver can be used to set the SV Servo to any IPv4 address and protocol. The IP address and protocol will be stored in nonvolatile memory and used on subsequent power-ups.	2.2b
<i>Use the AMCI NET Configurator Utility</i>	No restrictions on use. The software can be used to set the SV Servo to any IPv4 address and protocol. The IP address and protocol choice will be stored in nonvolatile memory and used on subsequent power-ups.	2.2c

Table T2.1 Methods for Setting the IP Address

NOTE  There is a MAC address label on each SV Servo which has a writable surface. There is room on the label for writing the programmed IP address of the unit. It is a best practice to use this label to document the IP address of the unit in case it is ever repurposed.

NOTE  When using EtherNet/IP, the SV Servo units also supports the DHCP protocol. You will need an EtherNet/IP DHCP server, such as the one available from Rockwell Automation, in order to use this protocol. The AMCI Net Configurator utility offers the same functionality and should be used unless your company policy prevents you from installing third party utilities. Contact AMCI for instructions if you must use the DHCP protocol.

2.2a Use Factory Default Settings

The factory default address for the SV Servo unit is 192.168.0.50 with a subnet mask of 255.255.255.0. The easiest way to verify this address is with the ping command as described in the *Test Your Network Interface* section found on page 86.

If the driver does not respond to this address then it may take some effort to determine the correct address. There is a label on the driver that lists the MAC address of the device. There is space on the label for noting the IP address of the device if it is changed. If the address was not documented, a program called Wireshark (<https://www.wireshark.org/>) can be used to determine the address of the driver.

2.2b Use the Embedded Web Server

PREREQUISITE: You must know the present IP address of the SV Servo. The factory default address is 192.168.0.50.

PREREQUISITE: Task 1.8: *Power Wiring* found on page 95. You must be able to power the SV Servo.

PREREQUISITE: Tasks: 1.14 and 1.15, 1.16, or 1.17, starting on page 101. You must attach your SV Servo to your computer.

PREREQUISITE: Reference 8: *Configuring Network Interfaces* which starts on page 85. The network interfaces on your computer must be on the same subnet before you can communicate with an SV Servo.

2.2b.1 Disconnect the SV Servo from the host controller and cycle power to the unit

This ensures that the unit does not have any open connections to the host controller.

2.2b.2 Start your web browser and connect to the SV Servo

The internal HTML pages should work with any browser. Once your web browser is running, enter the present IP address of the SV Servo into the address bar. The default address is 192.168.0.50. The unit will respond with the following page.

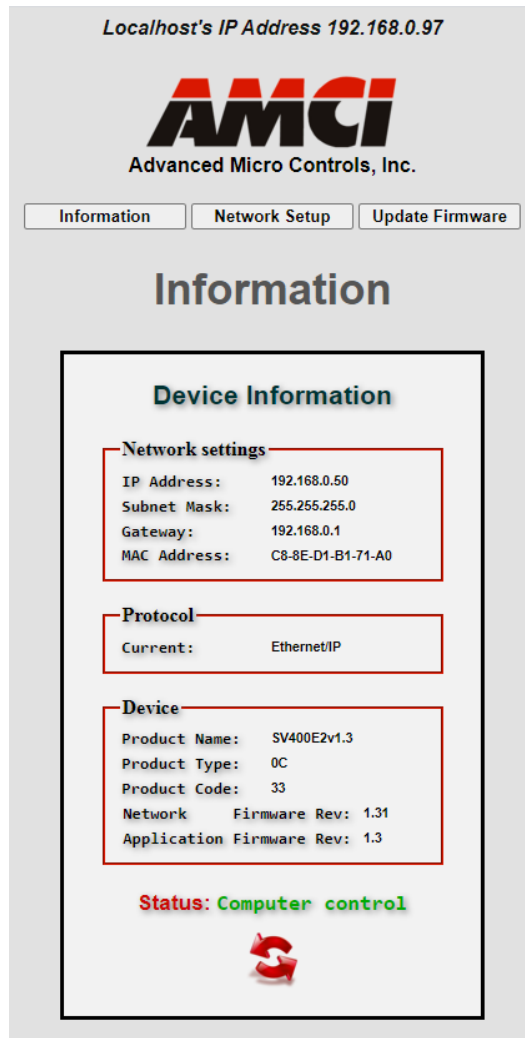

Figure T2.1 SV Servo Information Webpage

2.2b Use the Embedded Web Server (continued)

2.2b.3 Network Setup Page

- 1) Click on the [Network Setup] button to switch to the Network Setup page shown below. This page shows the current IP address settings, as well as the configured protocol.

Figure T2.2 SV Servo Network Setup Web Page

- 2) Enter your desired values into the IP Address, Subnet Mask, and Default Gateway fields.

NOTE  The Default Gateway setting is not optional! It must be set to a valid address on the chosen subnet. Because the Default Gateway is often not used in device level networks, if you do not have a required value for it, AMCI suggests setting the Default Gateway to the IP address of your host controller.

- 3) If need be, click on the proper radio button to select the required protocol.
- 4) Click on the [Write Configuration] button to write the new configuration to the unit. If there are any errors with the data, the unit will display a warning message instead of accepting the new values.

2.2b Use the Embedded Web Server (continued)

2.2b.3 Network Setup Page (continued)

5) If the values are accepted, the following pages will be displayed while the data is being written to the unit.

NOTE ⚠️ Wait for the pop up window to appear before cycling power to the SV Servo. Cycling power before this window appears may corrupt the non-volatile memory of the unit. The SV Servo unit will also flash its Network Status LED red to indicate that power must be cycled.

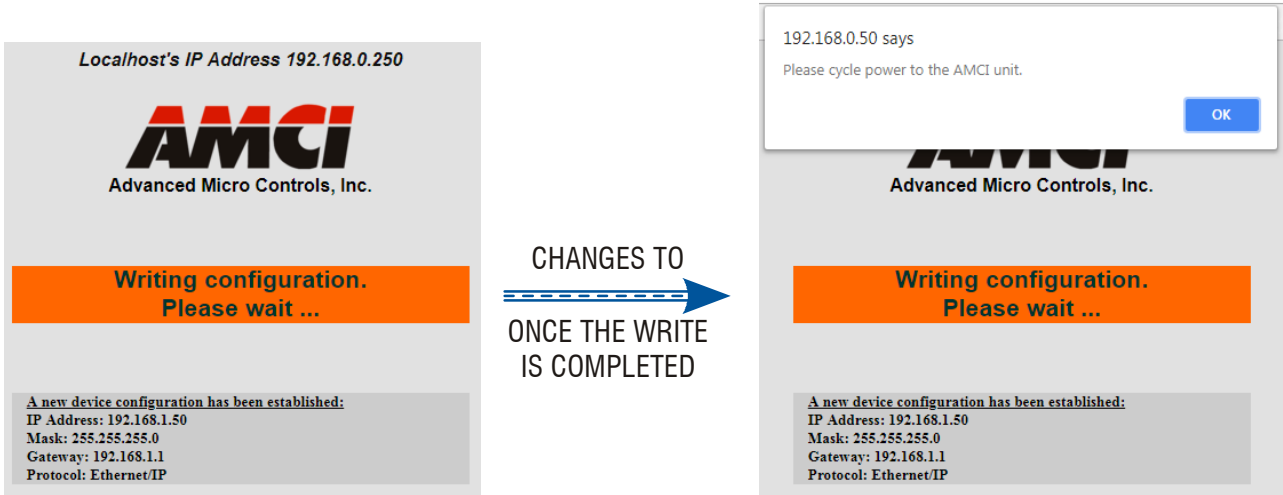

Figure T2.3 Write Configuration to Flash Memory Pages

6) Once instructed to, cycle power to the unit. You can now enter the new IP address into the address bar of your web browser to reconnect with the SV Servo.

2.2c Use the AMCI NET Configurator Utility

PREREQUISITE: You must know the present IP address. The factory default address is 192.168.0.50.

PREREQUISITE: Task 1.8: *Power Wiring* found on page 95. You must be able to power the SV Servo.

PREREQUISITE: Tasks: 1.14 and 1.15, 1.16, or 1.17, starting on page 101. You must attach your SV Servo to your computer.

PREREQUISITE: Reference 8: *Configuring Network Interfaces* which starts on page 85. The network interfaces on your computer must be on the same subnet before you can communicate with the unit.

2.2c.1 Download the AMCI Net Configurator Utility

The AMCI Net Configurator utility is available on our website, www.amci.com. The latest version available should be used. It can be found in our *Support* section under *Software*. The program exists as a ZIP file, and at the time of this writing, the link was “AMCI NET Configurator Utility for all networked products...”.

2.2c.2 Install the AMCI Net Configurator Utility

Once downloaded, simply extract the program from the ZIP file and run the program to install the AMCI Net Configurator utility on your computer. The software installs as most products do, giving you the option to change the file locations before installing the utility. Once the install is complete, a link to the utility is available on the Start Menu.

The install process only copies the utility to the designated location and creates links to the Start Menu. No changes are made to your registry settings.

2.2c.3 Verify that Your Host Controller is Disconnected from the SV Servo

EtherNet/IP is not a multi-master protocol. There can be only one bus master on the network at a time. In order to program the SV Servo, the AMCI Net Configurator utility must act as a bus master. Therefore, physically disconnect your host controller from the SV Servo before starting the Net Configurator utility.

2.2c.4 Apply or Cycle Power to the SV Servo

Cycling power to the SV Servo will reset any connections it may have with the host controller.

2.2c Use the AMCI Net Configurator Utility (continued)

2.2c.5 Start the AMCI Net Configurator Utility

Double click on the utility’s icon. A welcome screen similar to the one in figure T2.4 below will appear.

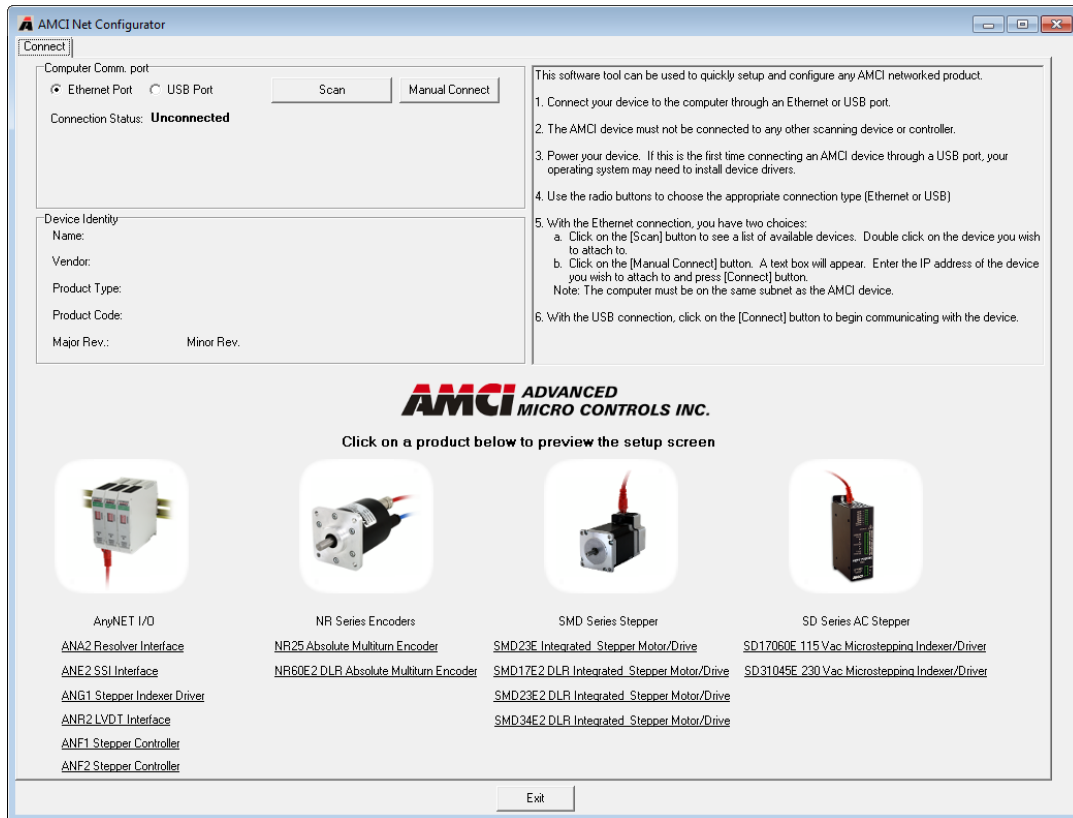

Figure T2.4 Net Configurator Welcome Screen

2.2c Use the AMCI Net Configurator Utility (continued)

2.2c.6 Press the [SCAN] button and Connect to the SV Servo

Pressing the [Scan] button will open the window shown in figure T2.5. Note that scanning for the SV Servo will only work when the unit and your network interface are on the same subnet. Optionally, you can press the [Manual Connect] button and enter the IP address of the unit.

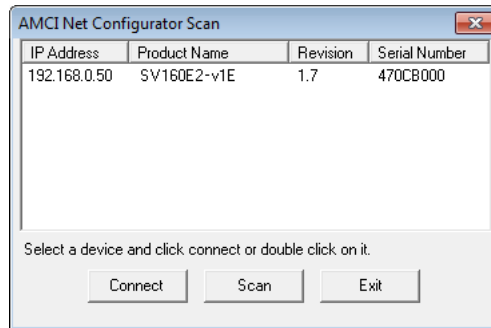

Figure T2.5 Scan for SV Servo device

If scanning for the SV Servo device, click on the IP Address of the unit and click on the [Connect] button. The Net Configurator utility will connect to the unit.

2.2c.7 Click on the "Allow IP..." Checkbox to Access the IP Settings

Figure T2.6 below shows the screen that results when you are connected to the SV Servo. In order to change the IP Address of the unit, you must first click on the checkbox next to the text "Allow IP configuration changes. You will need to restart the device." Once the checkbox is selected, the [Set IP Address] and protocol select buttons will be enabled.

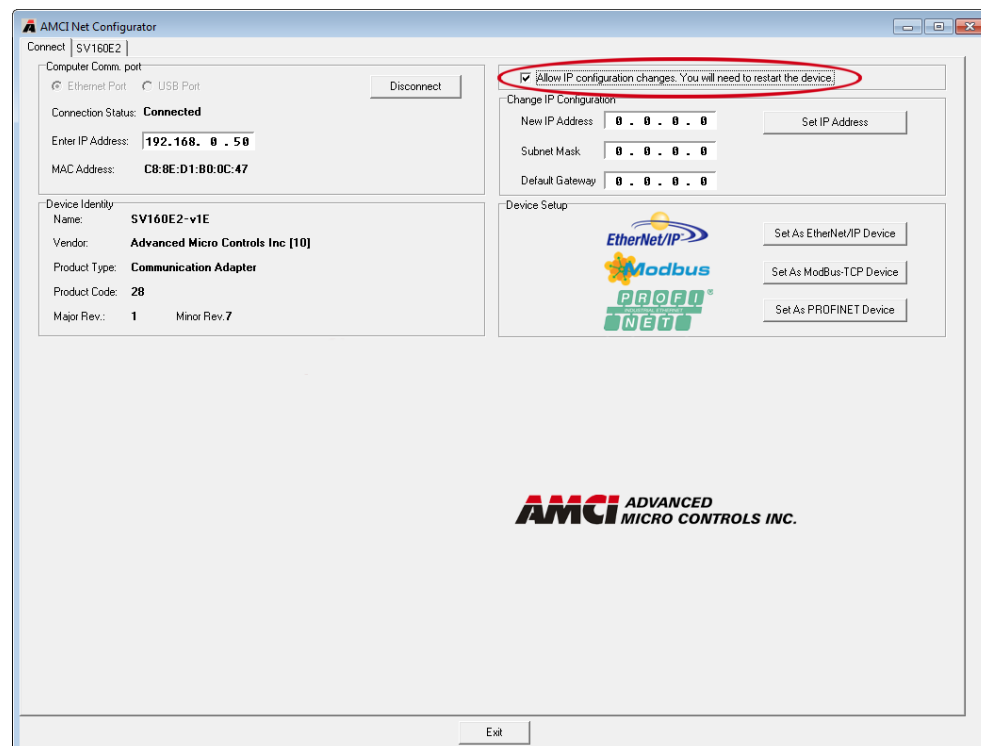



Figure T2.6 Enable IP Address Changes

2.2c Use the AMCI Net Configurator Utility (continued)**2.2c.8 Set the IP Address, Subnet Mask, and Default Gateway**

Enter your desired values into the IP Address, Subnet Mask, and Default Gateway fields.

NOTE  The Default Gateway setting is not optional! It must be set to a valid address on the chosen subnet. Because the Default Gateway is often not used in device level networks, if you do not have a required value for it, AMCI suggests setting the Default Gateway to the IP address of your host controller.

2.2c.9 Write the New IP Address to the SV Servo

Click on the [Set IP Address] button. If there is an error in the settings, the utility will tell you what is wrong. Once they are all correct, the utility will write the new IP address settings to the unit. These settings are automatically saved to nonvolatile memory.

2.2c.10 Set the Communications Protocol

The factory default protocol for the SV Servo is EtherNet/IP. In order to use the Modbus TCP or PROFINET protocols, simply click on the appropriate button.

NOTE  If changing the IP address and the communications protocol, click on the [Set IP Address] button to set the IP address before changing the protocol. Once the protocol is changed, the SV Servo will not accept changes to the IP address until power is cycled to the unit.

2.2c.11 Remove Power from the SV Servo

The new IP address and or communications protocol will not be used until power to the unit has been cycled.

Task Complete

TASK 3 (EtherNet/IP Option)

IMPLICIT COMMUNICATIONS WITH AN EDS

Many EtherNet/IP platforms support the use of EDS files to simplify the addition and configuration of devices. This chapter covers the installation and use of the EDS file for systems that are programmed with Rockwell Automation Studio 5000 version 20 and above. Other systems will follow a similar pattern. Consult your controller's documentation if you need additional information.

Note: Use of an EDS file is completely optional. The SV Servo can always be added to a system as a generic module. If you are using RSLogix 5000 version 19 and below, or RSLogix 500, adding the unit as a generic module is the only option available.

3.1 Obtain the EDS file

All AMCI EDS files are located on our website at the following address:

➤ <http://www.amci.com/industrial-automation-support/configuration-files/>

Simply download the appropriate ZIP file and extract it to its own directory. The ZIP file contains the EDS text file and a custom icon file for the device.

NOTE ⚠ The screen captures in this chapter use the EDS file for the SV160E2 as an example. The steps are identical for the SV400E2.

3.2 Install the EDS file

3.2.1 Start the EDS Hardware Installation Tool

1) Once Studio 5000 is running, in the menu bar select Tools → EDS Hardware Installation Tool. This will open the EDS Wizard.

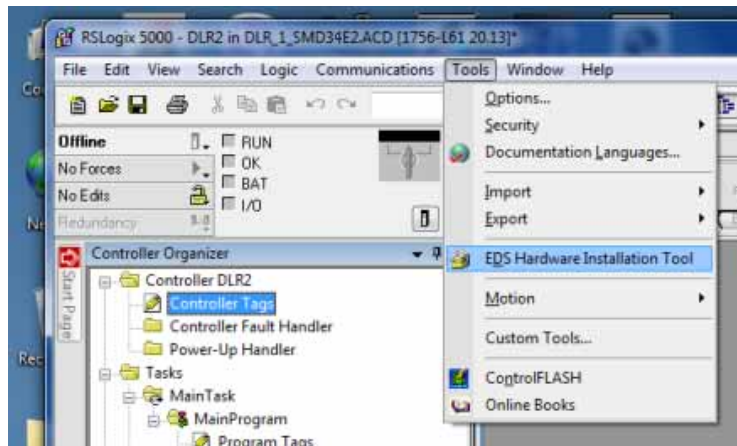

Figure T3.1 Opening the EDS Wizard

2) Click on [Next >] to advance to the Options screen.

3.2 Install the EDS file (continued)

3.2.2 Install the EDS File

1) On the Options screen, select the Register an EDS file(s) radio button and press [Next >].

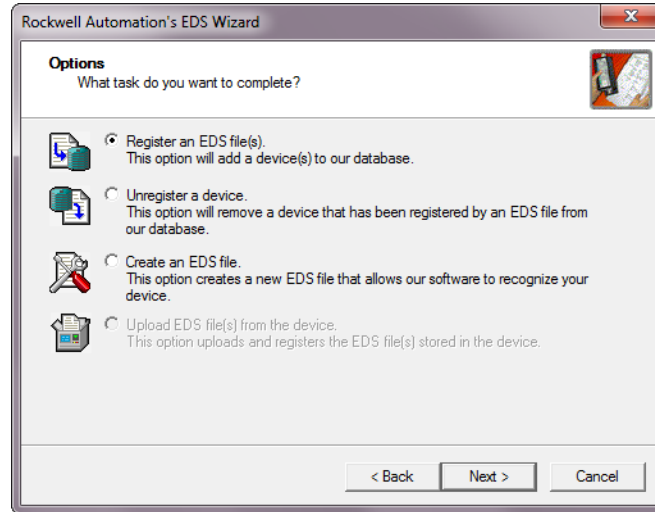

Figure T3.2 EDS Options Screen

2) The registration screen will open. Select the Register a single file radio button.

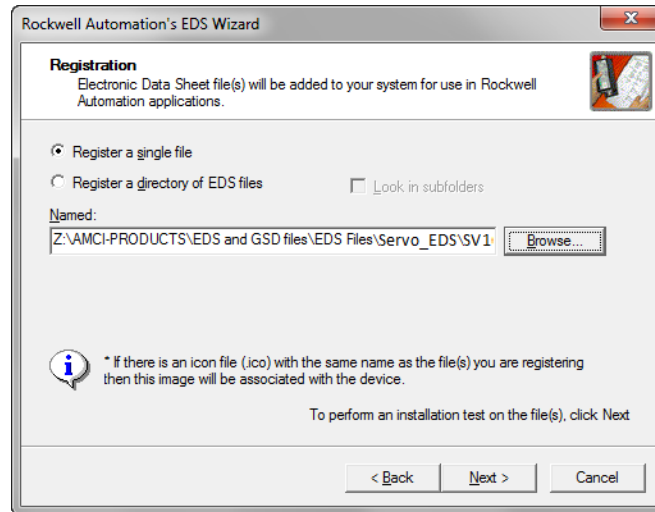

Figure T3.3 EDS Registration Screen

3) Click on the [Browse...] button and browse to the folder that contains the extracted EDS file you downloaded from the AMCI website. Select the EDS file and click on the [Open] button to return to the registration screen. Click on the [Next >] button to advance to the EDS file test screen.

3.2 Install the EDS file (continued)

3.2.2 Install the EDS File (continued)

- 4) Once at the EDS File Installation Test Results screen, expand the tree as needed to view the results of the installation test for the EDS file. You should see a green check mark next to the file name indicating that the EDS file is correct.

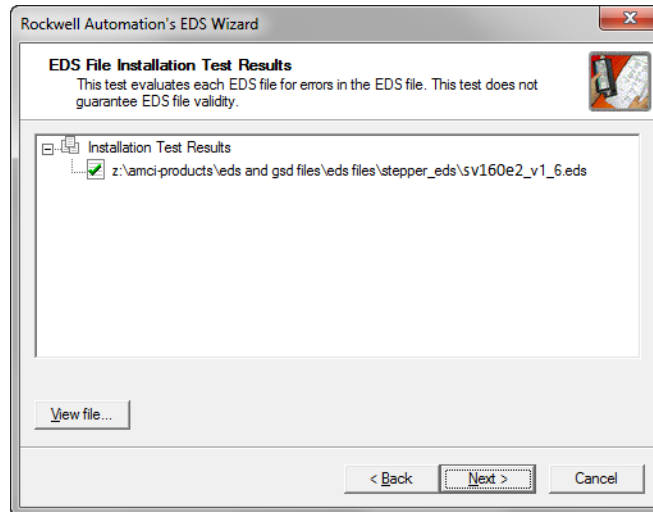

Figure T3.4 EDS Test Screen

- 5) Press on the [Next >] button to advance to the Change Graphic Image screen. This screen gives you the ability to change the icon associated with the device.

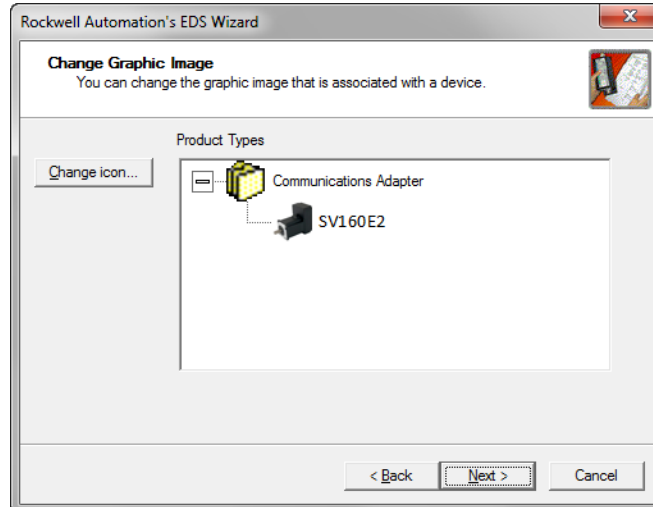

Figure T3.5 Change ECS Icon Screen

- 6) Click on the [Change icon...] button. In the window that opens, click on [Browse...] and browse to the folder that contains the extracted EDS and icon files you downloaded from the AMCI website.
- 7) Select the icon file (*.ico) associated with the device. Click on the [Open] button and then on [OK] to return to the Change Graphic Image screen.
- 8) Click on the [Next...] button to advance to the completion screen. The Completion screen tells you that you have successfully completed the wizard.
- 9) Click on the [Finish] button to exit the EDS wizard.

3.3 Host System Configuration

Studio 5000 is used to configure both the ControlLogix and CompactLogix platforms. When using these platforms, you have the option of using a separate Ethernet Bridge module or an Ethernet port built into the processor.

If the Ethernet port is built into processor, the only step you have to take before adding an AMCI SV Servo is to create a new project with the correct processor or modify an existing project. Once this is done, the Ethernet port will automatically appear in the Project Tree. If you are using an Ethernet bridge module, you will have to add it to the I/O Configuration tree before adding the unit to your project.

Refer to your Rockwell Automation documentation if you need instructions for configuring the ethernet port.

3.4 Add the SV Servo to Your Project

You can add an AMCI SV Servo to the project once the Ethernet port (built-in or bridge module) is configured. As shown in figure T3.6 below, the Ethernet port will be listed under the I/O Configuration tree.

- 1) Right click on the Ethernet port and then click on “New Module...” in the pop-up menu.

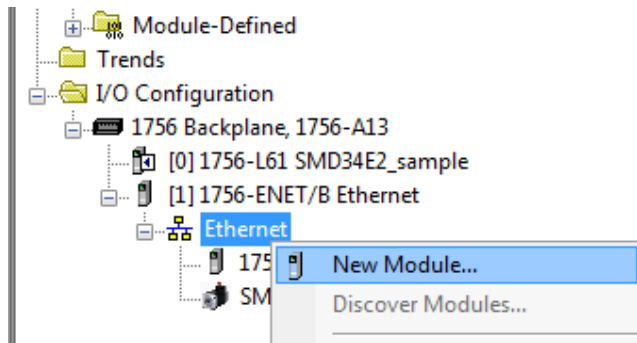

Figure T3.6 Adding an AMCI Ethernet Driver

- 2) In the resulting Select Module Type screen, select “Advanced Micro Controls Inc. (AMCI)” in the Vendor Filters. This will limit the results to catalog numbers from AMCI.
- 3) Select the appropriate device in the resulting list.
- 4) Click on the [Create] button to create the module.
- 5) Click on [Close] if necessary to close the Select Module Type screen.

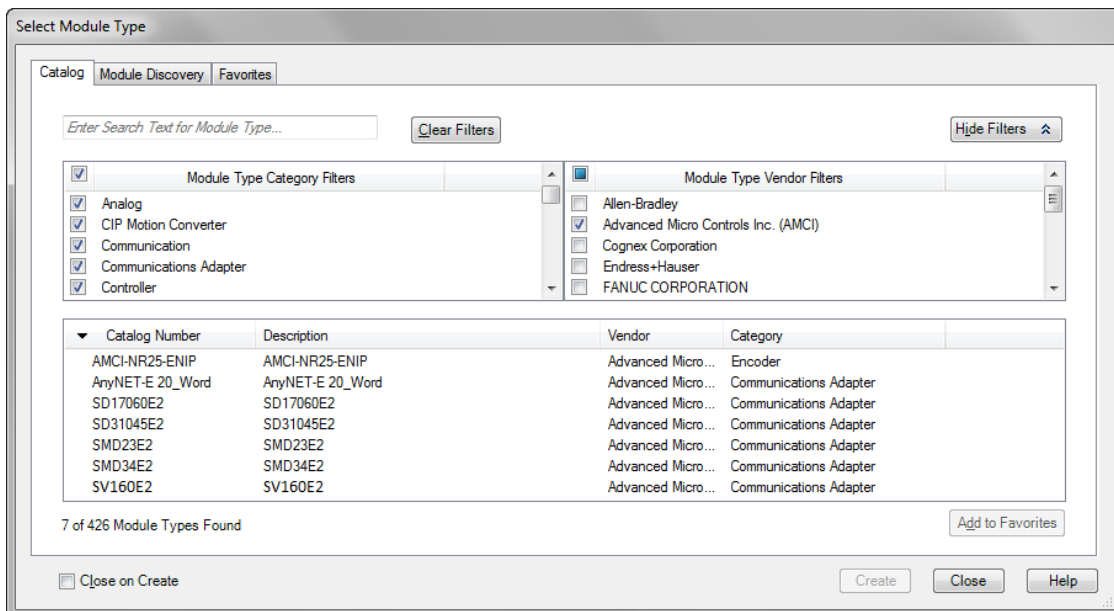



Figure T3.7 Selecting the AMCI SV Servo

3.5 SV Servo Properties Setup

If you are continuing from step 3.4, the resulting New Module screen is used to configure the network connection between the SV Servo and your controller. If you need to open the screen to perform this task at a later time, right click on the SV Servo in the project tree and then select “Properties” from the drop-down menu.

NOTE  Tabs that are not listed in the steps below are filled with reasonable defaults by the EDS file.

3.5.1 General Tab

The Name, Description, and IP address of the device must be specified here. The [Change...] button allows you to change the Module Definition if needed.

3.5.2 Connection Tab

The default RPI time is eight milliseconds. This value can be changed in this tab.

3.5.3 Configuration Tab

The Configuration tab is used to define the configuration data that is written down to the SV Servo when the device connects to the network. You can also click on the [Apply] button to write down the configuration data to the unit at any time.

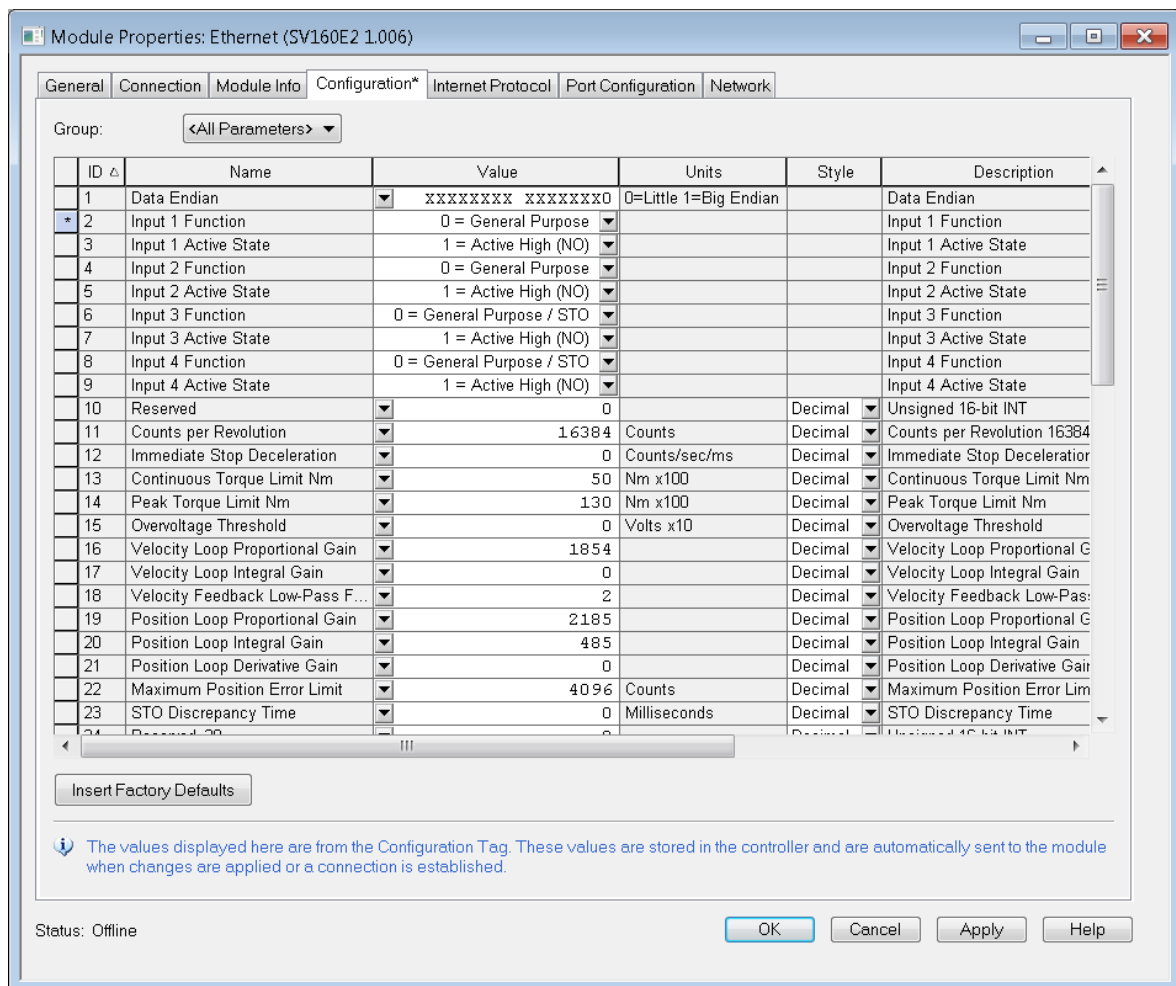

Figure T3.8 SV Servo Configuration with EDS File

The EDS file defines tags that are used to configure the SV Servo. These tags follow the format of the Configuration Data given in reference chapter 6, *Configuration Mode Data Format*, starting on page 49.

3.6 Buffering the I/O Data

Input and output data is transferred asynchronously to the program scan. The input data tags should be buffered with Synchronous Copy File instructions to guarantee stable input data during the program scan.

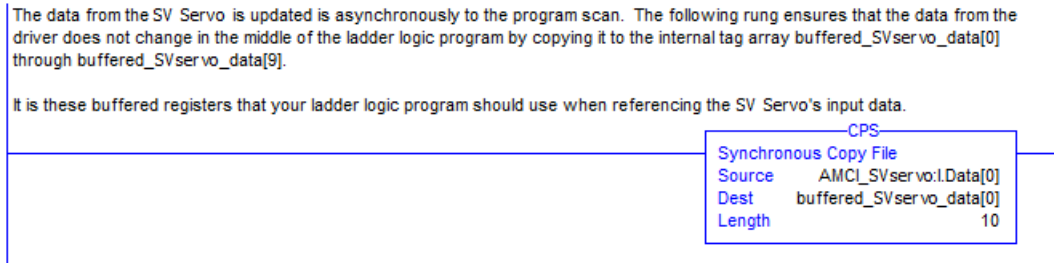

Figure T3.9 Buffer I/O Data

- When copying input data, the data can be converted from byte to integer format by specifying an integer array as the destination for the instruction. The array must contain at least ten integer elements. The length of the copy should be ten.

The format of the output and input data is covered in the *Configuration Mode Data Format* and *Command Mode Data Format* reference chapters, starting on pages 49 and 63 respectively.

TASK 4 (EtherNet/IP Option)

ETHERNET/IP EXPLICIT MESSAGING

All controllers that support EtherNet/IP support explicit messaging. When using explicit messaging, Message Instructions must be added to your program to communicate with the SV Servo. Explicit messaging can also be used on platforms that also support implicit messaging.

Rockwell Automation controllers which are programmed with the RSLogix 500 software only support explicit messaging. A MicroLogix 1100 will be used as an example in this chapter.

4.1 Required Message Instructions

Two instructions are required to transfer data between the PLC and the SV Servo. One instruction reads data from the unit and the other writes data to it. The following table gives the required attributes for the instructions.

	Read Instruction	Write Instruction
Service Type	Read Assembly	Write Assembly
Service Code	E (hex)	10 (hex)
Class	4 (hex)	4 (hex)
Instance	100 (decimal)	150 (decimal)
Attribute	3 (hex)	3 (hex)
Length	20 bytes	20 bytes

Table T4.1 Message Instruction Attributes



Only RSLogix 500 version 8.0 or above can be used to configure Message Instructions to communicate with an EtherNet/IP device. Message Instructions in version 10 of RSLogix 500 do not work correctly.

4.2 Create Four New Data Files.

- An Integer file to contain the data from the SV Servo. This file must be at least 10 words in length.
- An Integer file to contain the data sent to the SV Servo. This file must be at least 10 words in length.
- A Message (MG) data file. This file must have at least two elements, one to control the Read Operation and one to control the Write Operation.
- An Extended Routing Information (RIX) data file. This file is used to store information used by the Message Instructions. This file must have at least two elements, one for the Read Operation and one for the Write Operation.

4.3 Add the Message Instructions to your Ladder Logic

The following rungs show how you can alternately read data from and write data to your SV Servo.



Figure T4.1 Message Instruction Example

- 1) Double click on *Setup Screen* text inside the Message Instruction. The following window will open. Note that this is the default window and its appearance will change considerably as you progress through these steps.

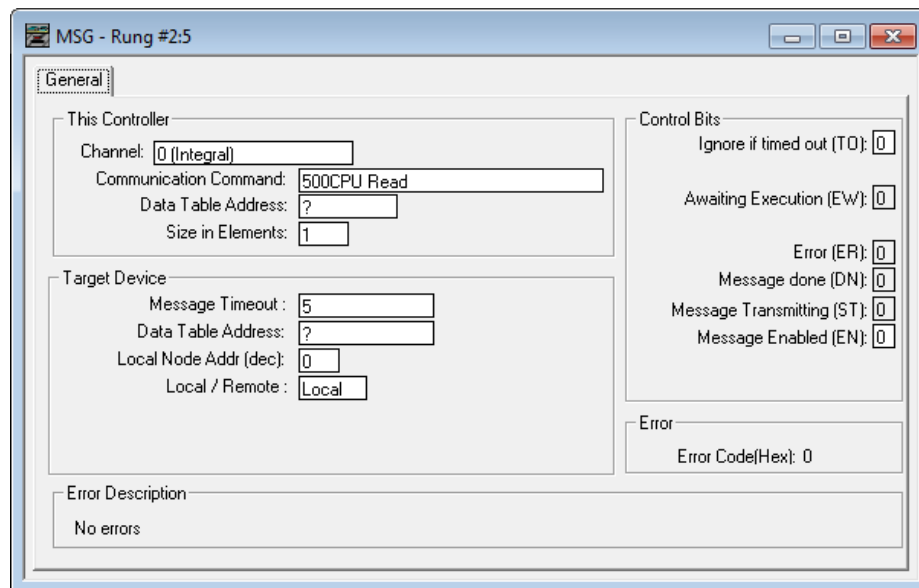

Figure T4.2 Message Instruction Setup Screen

- 2) Double click in the *Channel* field, click on the ▼, select “1 (Integral)”, and press Enter.
- 3) Double click in the *Communication Command* field, click on the ▼, select “CIP Generic” and press Enter.
- 4) If the Message Instruction is being used to read data from the SV Servo, enter the integer file where the data will be placed in the *Data Table Address (Received)* field and press enter.
- 5) If the Message Instruction is being used to write data to the SV Servo, enter the integer file where the source data will be located in the *Data Table Address (Send)* field and press Enter.
- 6) Enter “20” as the number of bytes needed in either the *Size In Bytes (Receive)* or *Size In Bytes (Send)* fields. The SV Servo requires 20 bytes for both Receive and Send.
- 7) Enter a RIX address in the *Extended Routing Info* field. Please note that each Message Instruction must have its own RIX address.

4.3 Add the Message Instructions to your Ladder Logic (continued)

- 8) Double click in the *Service* field and select “Read Assembly” for a Message Instruction that is being used to read data from the SV Servo, or “Write Assemble” for a Message Instruction that is being used to send data to the SV Servo, and press Enter.
- 9) For *Read* operations, the *Service Code* field will change to “E” (hex). For *Write* operations, the *Service Code* field will change to “10” (hex). For both read and write operations, the *Class* field will change to “4” (hex), and the *Attribute* field will change to “3” (hex).
- 10) For Read operations, enter a value of 100 decimal (64 hex) in the *Instance* field.
For Write operations, enter a value of 150 decimal (96 hex) in the *Instance* field.

The figure below show a typical configuration for Message Instructions being used to read data from the SV Servo. Please note that the Data Table Address (Receive) field may be different in your application.

The screenshot shows the 'MSG - Rung #2:5' configuration window. The 'General' tab is selected. The configuration is as follows:

- This Controller:**
 - Channel: 1 (Integral)
 - Communication Command: CIP Generic
 - Data Table Address (Receive): N9:0 (Send: N/A)
 - Size in Bytes (Receive): 20 (Send: N/A)
- Target Device:**
 - Message Timeout: 5
 - Local / Remote: Local
 - MultiHop: Yes
 - Extended Routing Info File (RIX): RIX10:0
 - Service: Read Assembly
 - Service Code (hex): E
 - Class (hex): 4 (dec): 4
 - Instance (hex): 64 (dec): 100
 - Attribute (hex): 3 (dec): 3
- Control Bits:**
 - Ignore if timed out (TO): 0
 - Break Connection (BK): 0
 - Awaiting Execution (EW): 0
 - Error (ER): 0
 - Message done (DN): 0
 - Message Transmitting (ST): 0
 - Message Enabled (EN): 0
- Error:**
 - Error Code (Hex): 0
- Error Description:** No errors

Figure T4.3 Read Message Instruction Setup Screen

4.3 Add the Message Instructions to your Ladder Logic (continued)

The figure below show a typical configuration for Message Instructions being used to write data to the SV Servo. Please note that the Data Table Address (Send) field may be different in your application.

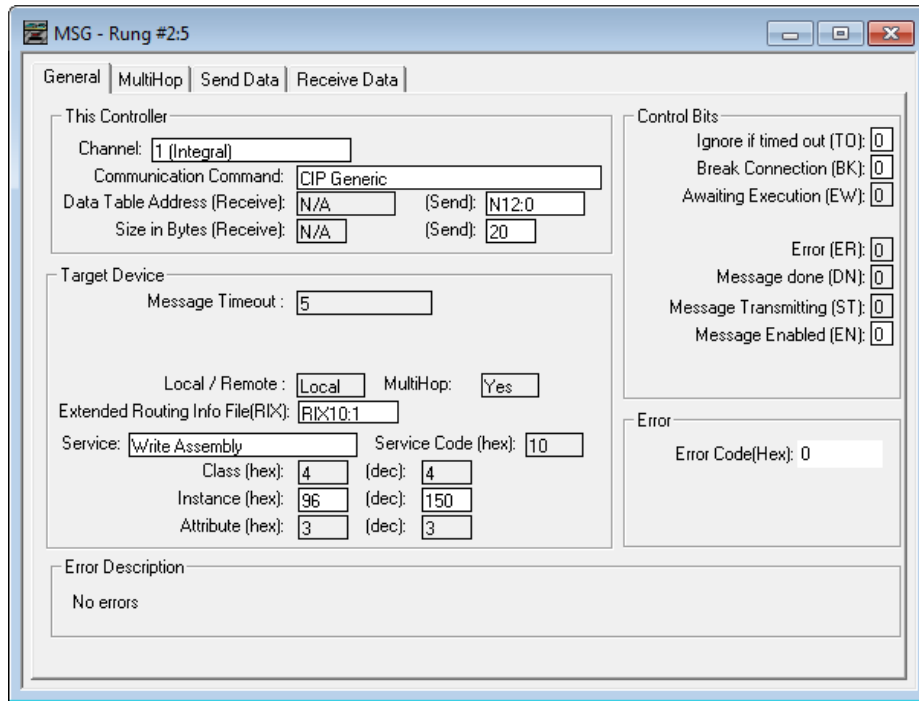

Figure T4.4 Write Message Instruction Setup Screen

Click on the MultiHop tab on the top of the window. As shown in figure T4.5, enter the IP address of the SV Servo and press Enter.

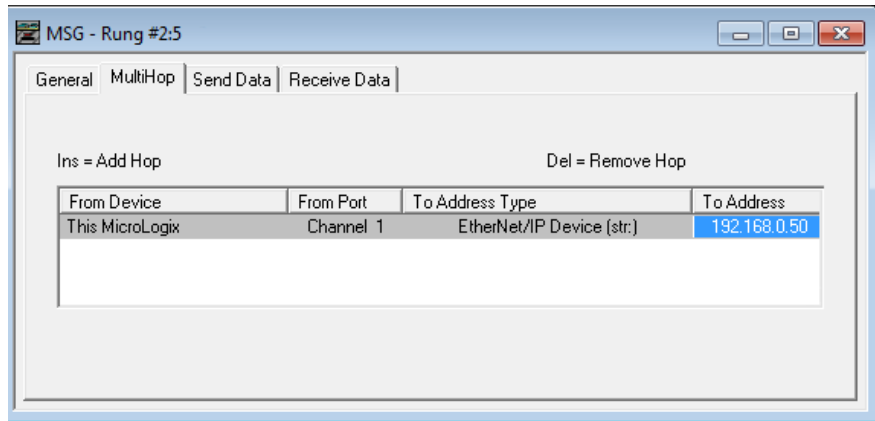

Figure T4.5 Message Instruction MultiHop Settings

After you are finished adding both the read and write message instructions to your program, save and download the program to the PLC.

4.4 Troubleshooting

If you are unable to communicate with the SV Servo, the problem may be that the Ethernet port of your MicroLogix 1100 has not been configured. To check this:

- 1) Double click on Channel Configuration in the Project Tree and then select the Channel 1 tab. The following window will open.

The screenshot shows the 'Channel Configuration' dialog box with the 'Channel 1' tab selected. The 'Driver' is set to 'Ethernet'. The 'Hardware Address' is '00:0F:73:00:CB:3E' and the 'Network Link ID' is '0'. The IP configuration is set to '192.168.0.1' with a subnet mask of '255.255.255.0' and a gateway of '0.0.0.0'. The 'Protocol Control' section has 'HTTP Server Enable' checked, and 'Msg Connection Timeout' set to 15000, 'Msg Reply Timeout' to 3000, and 'Inactivity Timeout' to 30. The 'Auto Negotiate' checkbox is checked, and the 'Port Setting' is '10/100 Mbps Full Duplex/Half Duplex'. There are 'OK', 'Cancel', 'Apply', and 'Help' buttons at the bottom.

Figure T4.6 MicroLogix Ethernet Configuration Screen

- 2) Enter the IP address and Subnet Mask of your MicroLogix 1100, (not the address of the SV Servo) and click on [Apply]. The Ethernet Port should now be working.

NOTE AMCI is aware of an issue with the RIX data type in version 10 of RSLogix 500. If you are experiencing communications errors and are running version 10, please contact Rockwell Automation for support.

Notes

TASK 5 (Modbus TCP Option)

MODBUS TCP CONFIGURATION

An AMCI SV Servo that has been configured for the Modbus TCP protocol requires a host controller to issue configuration data and motion commands to the unit. This chapter tells you how the I/O words used by an AMCI SV Servo are mapped to the Modbus I/O registers.

5.1 Enable Modbus TCP Protocol

The built-in webserver or AMCI Net Configurator utility can be used to change the communications protocol used by the SV Servo. This is typically done while setting the IP address. Refer to Task 2, *Set the IP Address and Protocol*, which starts on page 107, for information on using the built-in webserver or the AMCI Net Configurator utility.

5.2 Modbus Addressing

The register addresses used in this manual are the *Modbus logical reference numbers*[†], which are unsigned integers starting at zero. This is often called *zero based* addressing. In this scheme, the first register is given an address of zero. This is the actual addressing scheme used in the Modbus packets.

Another common addressing scheme is *one based* or *data model* addressing. In this scheme, the register's number is used as its address, so the first register, Register 1 in the data model, has an address of 1.

5.2.1 Modbus Table Mapping

The Discrete Input and Input Register tables in the Modbus data model map to the same physical memory locations in the SV Servo units.

- These registers hold data that is reported from the driver to the host controller. This data is typically command responses and status data.
- Addresses for these registers and inputs start at 0 in zero based addressing.

As examples:

- Discrete Input 0 is the same memory location as bit 0 of the first Input Register.
- Register address 3, the fourth register, contains Discrete Inputs 48 through 63.

The Coil and Holding Register tables in the Modbus data model map to the same physical memory locations in the SV Servo units.

- These registers hold data that is from the host controller to the unit. This data is typically commands.
- Addresses for these registers start at 1024 in zero based addressing. Coil addresses start at 16,384 in zero based addressing (1024*16).

As examples:

- Coil 16384 is the same memory location as bit 0 of the first Holding Register.
- Register address 1025, the address of the second Holding Register, contains Discrete Outputs 16,400 through 16,415 in zero based addressing.

5.2.2 Host Addressing

Your host controller may not use these basic addressing schemes for communicating over a Modbus connection. For example, Modicon controllers use addresses starting at 30000 for Input Registers and addresses starting at 40000 for Holding Registers. GE hosts internally use their %R memory for Holding Registers and %AI memory for Input Registers.

If this is the case, you will define a mapping between your host controller's addressing scheme and the zero based Modbus TCP addresses when you add the SV Servo to your host controller. Refer to your host controller's documentation for information on how to accomplish this.

[†] MODBUS Application Protocol Specification V1.1b3, section 4.3: MODBUS Data model. www.modbus.org

5.3 AMCI Modbus TCP Memory Layout

The SV Servo has a starting Input Register address of 0 and a starting Output Register address of 1024. Input Registers hold the data from the driver while Output Registers hold the data to be written to the unit. Figure T5.1 shows how an SV Servo is mapped to the Modbus data reference. The complete specification for the Modbus protocol may be available at <http://www.modbus.org/specs.php>.

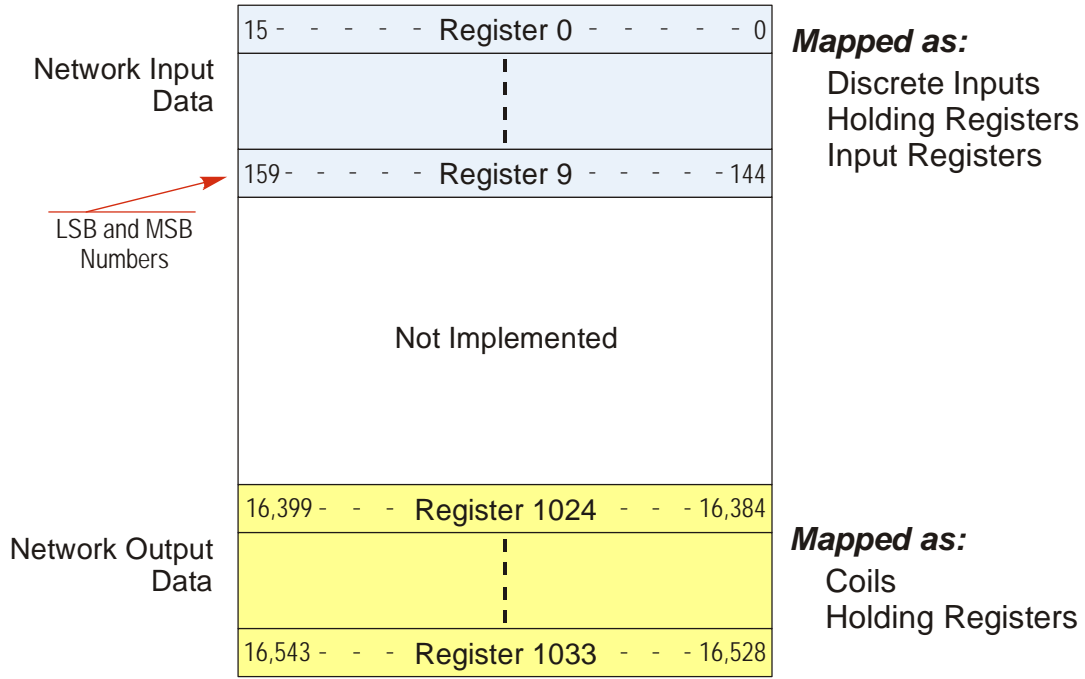

Figure T5.1 Modbus Data Reference Map

5.4 Supported Number of Connections

All SV Servo units support five concurrent connections. When connections exist, the Network Status (NS) LED on the back of the unit will flash green. The number of blinks indicate the number of active connections. There is a two second break between groups of flashes.

5.5 Supported Modbus Functions

Function Code	Function Name	SV Servo Register	Addressing method
1	Read Coils	OUTPUT	Bit: Addresses starting at 16,384
2	Read Discrete Inputs	INPUT	Bit: Addresses starting at 0
3	Read Holding Registers	OUTPUT & INPUT	Word: Out Regs. Starting at 1024 In Regs. Starting at 0
4	Read Input Registers	INPUT	Word: Addresses starting at 0.
5	Write Single Coil	OUTPUT	Bit: Addresses starting at 16,384
6	Write Single Register	OUTPUT	Word: Addresses starting at 1024
15	Write Multiple Coils	OUTPUT	Bit: Addresses starting at 16,384
16	Write Multiple Registers	OUTPUT	Word: Addresses starting at 1024
22	Mask Write Register	OUTPUT	Word: Addresses starting at 1024
23	Read/Write Registers	INPUT/OUTPUT	Word: Out Regs. Starting at 1024 In Regs. Starting at 0

Table T5.1 Supported Modbus Functions

Table T5.1 above lists all of the Modbus functions supported by an SV Servo. AMCI supports all of these functions so that you can control the unit as you see fit. However, if you are looking for the easiest way to interface with your unit, then you only need to use the *Read/Write Registers* function, which is function code 23.

NOTE  Each SV Servo buffers the data that is sent to it over the network. If you use the *Read/Write Registers* function to write configuration data to the unit, then the data read with that command will not contain the response to the new configuration data. The response to the new data will be sent with the next data read.

5.6 Supported Modbus Exceptions

Code	Name	Description
01	Illegal function	The SV Servo does not support the function code in the query
02	Illegal data address	The data address received in the query is outside the initialized memory area
03	Illegal data value	The data in the request is illegal

Table T5.2 Supported Modbus Exceptions

Notes

TASK 6 (PROFINET Option)

PROFINET NETWORK CONFIGURATION

This chapter outlines the steps commonly needed to get an SV Servo communicating with the PROFINET master. A Siemens SIMATIC S7-1212C controller is used as an example.

Basic Steps

Configuring a PROFINET host requires a few basic steps.

- 1) Download the ZIP archive that contains the GSDML files for the SV Servo from the www.amci.com website.
- 2) Install the GSDML file into the configuration software for your host controller.
- 3) Add the SV Servo to the PROFINET Network.
- 4) Set the I/O word addresses used to communicate with the unit.



The screen captures in this chapter use the SV160E2 as an example. The steps are identical for the SV400E2.

6.1 Download the GSDML files

The GSDML files are available on the AMCI website on the <http://www.amci.com/industrial-automation-support/configuration-files/> web page. The file is a ZIP archive that has to be extracted to a folder on your computer. Extracting the ZIP file will leave you with multiple files. One is the GSDML file and the others are icon files for the various devices.

6.2 GSDML File Installation

- 1) Open or create a new project that will include the SV Servo and open the Project View of the project.
- 2) In the menu, select *Options -> Manage general station description files (GSD)*.
- 3) In the window that opens, click on the [...] button and navigate to the folder that contains the extracted GSDML file you downloaded from the AMCI website. Once at the folder, click on the [OK] button.
- 4) Click on the check box next to the name of the GSDML file and click on the [Install] button. The system will install the GSDML file.
- 5) Click the [Close] button and wait for the software to finish installing the file and updating the Hardware Catalog.

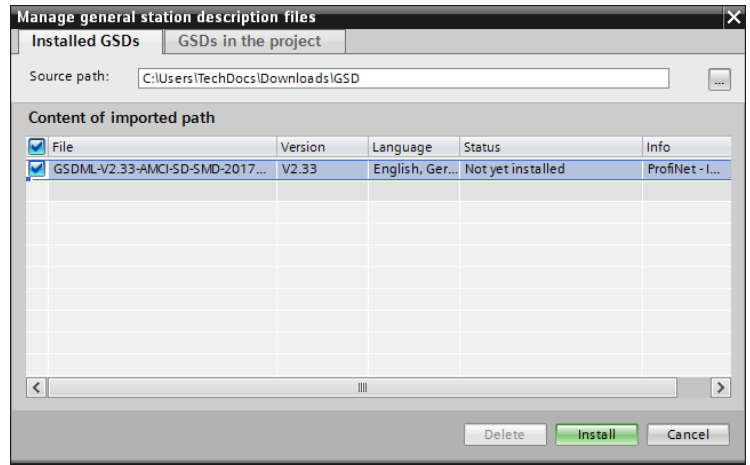

Figure T6.1 GSDML File Installation

6.3 Configure the PROFINET Network

A CPU must be added to the project and the PROFINET network must be configured before the SV Servo can be added to the system.

Refer to Siemens documentation for information on configuring the PROFINET network to suit your application.

6.4 Add the SV Servo to the PROFINET Network

- 1) With the project open in Project View, double click on “Device & Networks” in the project tree.
- 2) If need be, click on the “Hardware Catalog” vertical tab to open the Hardware Catalog.
- 3) You can search for “SV”, or browse to the proper SV Servo icon by clicking through *Other field devices* +> *PROFINET IO* +> *IO* +> *Advanced Micro Controls Inc.* +> *AMCI_Products* +> *AMCI_Drives*. Drag and drop the appropriate icon onto the PROFINET network.
- 4) Drag the green square on the SV Servo icon onto the PROFINET network line to connect the device to the network.

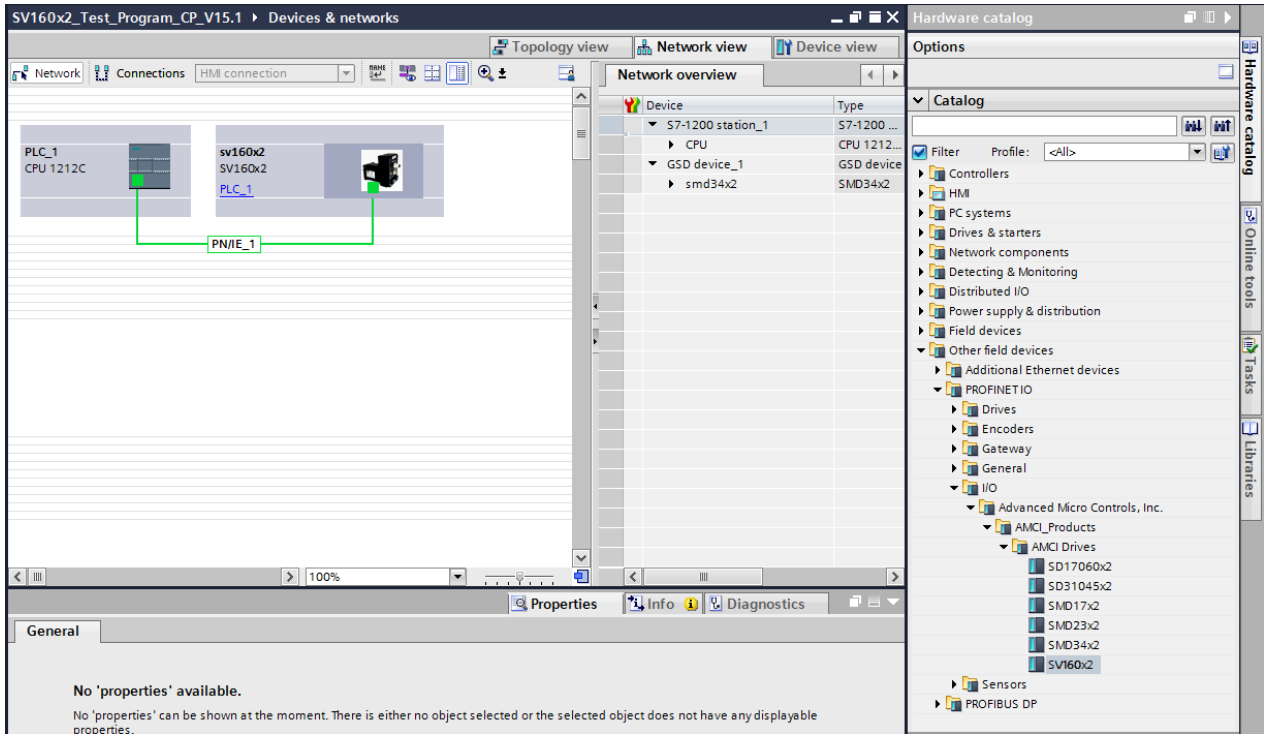

Figure T6.2 SV Servo Added to PROFINET Network

6.4 Add the SV Servo to the PROFINET Network (continued)

- 5) Right click on the SV Servo icon and select “Properties” from the pop up menu. The Inspector window will open at the bottom of the screen. Under the “General” tab, select the “►General” heading. You can rename the SV Servo by changing the Name: field.
- 6) Under the “►PROFINET interface [x1]” heading, select “Ethernet addresses”. Under the IP protocol section, set the desired IP address and subnet mask for the SV Servo.

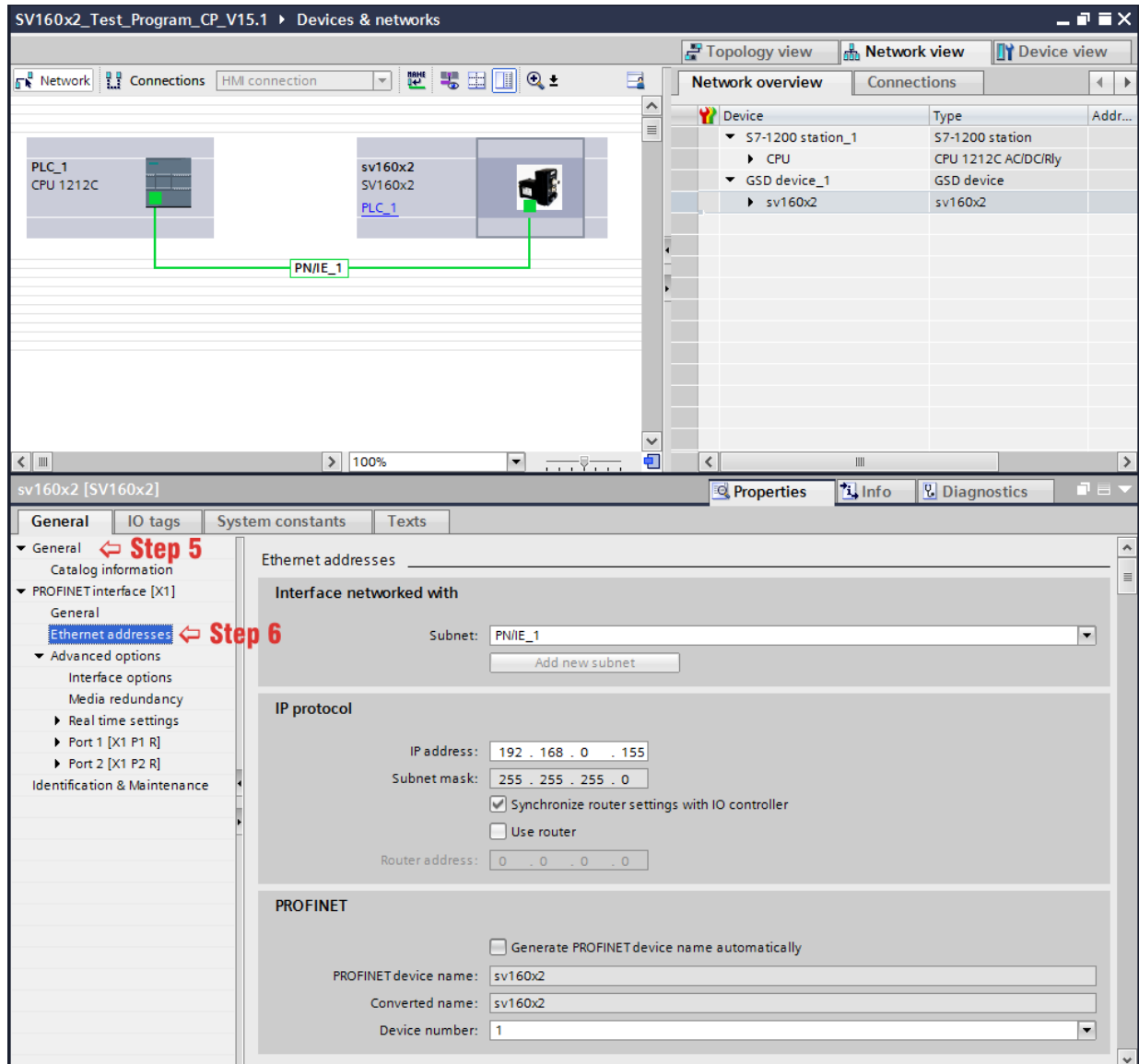

Figure T6.3 SV Servo IP Addressing

6.5 Configure the SV Servo

- Continuing with the Inspector Window, click on the “Module parameters” heading. The display will change to show all of the parameters of the SV Servo. These configuration parameters are written down to the SV160E2 or SV400E2 whenever it connects to the network.

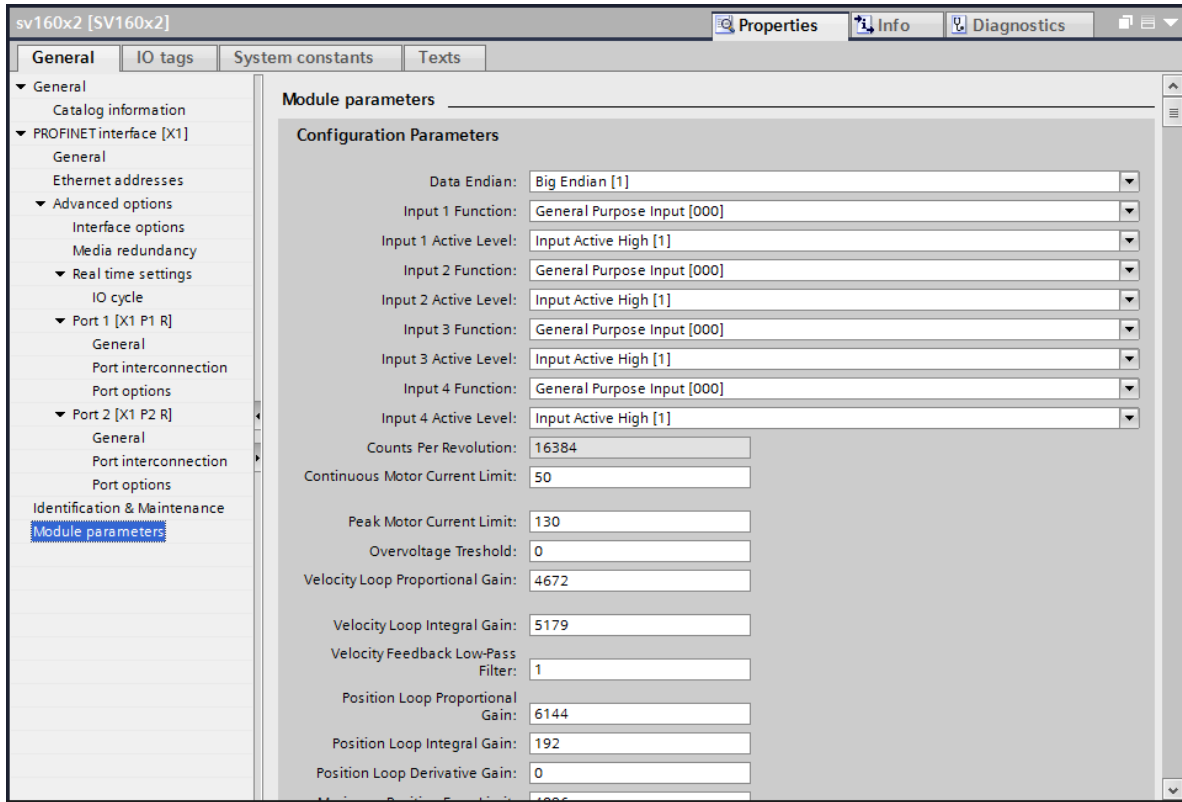

Figure T6.4 Configuration Parameters

- Configuration is done with a combination of drop down menus and value fields. Drop down menus limit you to a set of valid selections. When entering numbers into value fields, a pop up will appear that shows you the valid range of values.

NOTE

Even though your selections are limited, it is still possible to mis-configure the SV Servo by using this screen. For example, it is possible to configure two or more inputs as CW Limit Switches. If an error occurs, the SV Servo will show that a configuration error exists after it connects to the network.

NOTE

This data is only written to the unit when it connects to the network, which is typically on power up. The unit can still be reconfigured at any time by writing the appropriate data to the output registers of the SV Servo.

NOTE

These configuration parameters cannot be changed while on line. To make any changes, you must go off line, make the changes, save the project, download it, and then go back on line.

6.6 Set the I/O Configuration

The SV Servo units require 10 Input Words (20 Input Bytes) and 10 Output Words (20 Output Bytes). All required Input and Output Bytes are defined by the GSDML file and divided into suitable modules. These settings are shown in the Table T6.1.

Input / Output Bytes of an SV Servo	Input / Output Modules of an SV Servo
20 Input Bytes	Input Module - Slot 1: 20 bytes
20 Output Bytes	Output Module - Slot 2: 20 bytes

Table T6.1 PROFINET I/O Configuration

- 1) With the SV Servo icon selected on the PROFINET bus, click on the “Device view” tab. The view in the Hardware Catalog will change. Expand the Module tree to show both the Input and Output modules.
- 2) To map the I/O bytes to the CPU, double click on the “20 bytes IN” and “20 bytes OUT” icons in the Hardware Catalog. The system will automatically assign the next I and Q addresses to the data table.

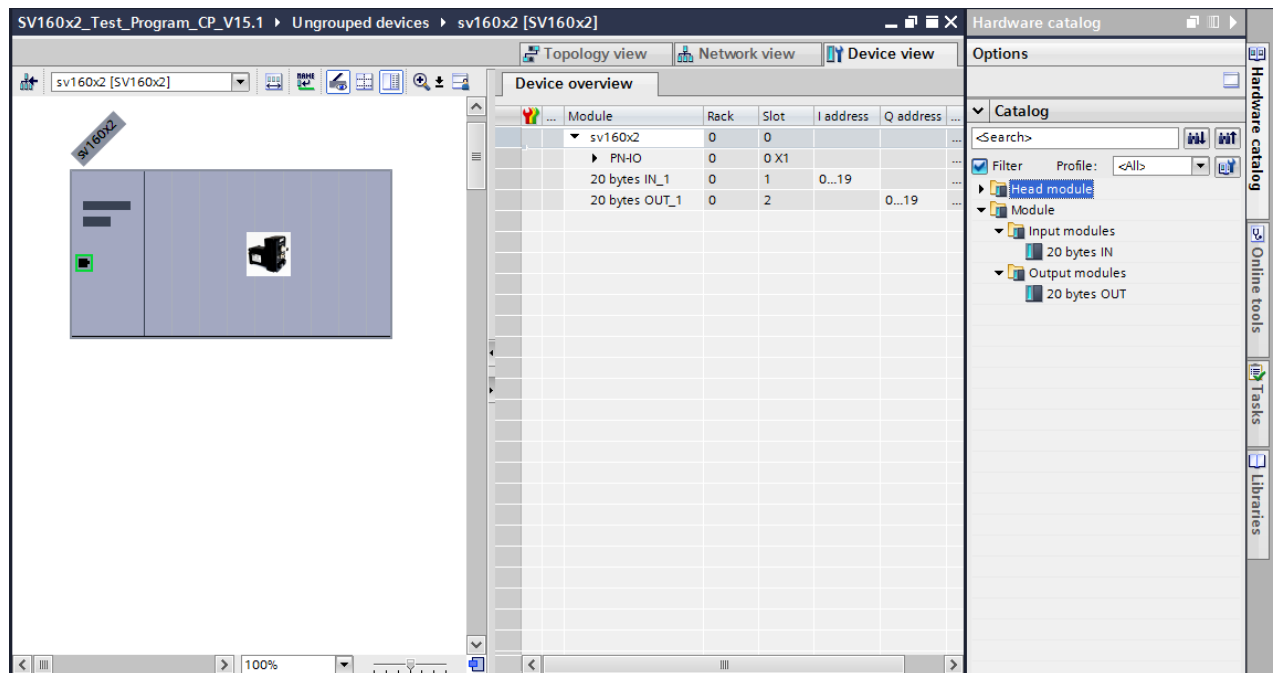

Figure T6.5 I/O Byte Mapping

6.7 Set the SV Servo Device Name

- 1) Right click on the SV Servo icon and select “Assign device name” from the resulting popup menu.
- 2) In the “Assign PROFINET device name.” windows that appears, click on the [Update list] button.
- 3) Once the SV Servo appears in the table, select the SV Servo in the table.
- 4) Confirm that the “PROFINET device name:” at the top of the screen is correct.
- 5) Click on the [Assign name] button to write the device name to the SV Servo. The “Online status information:” table at the bottom of the screen will show that the name was successfully assigned to the MAC address of the SV Servo.

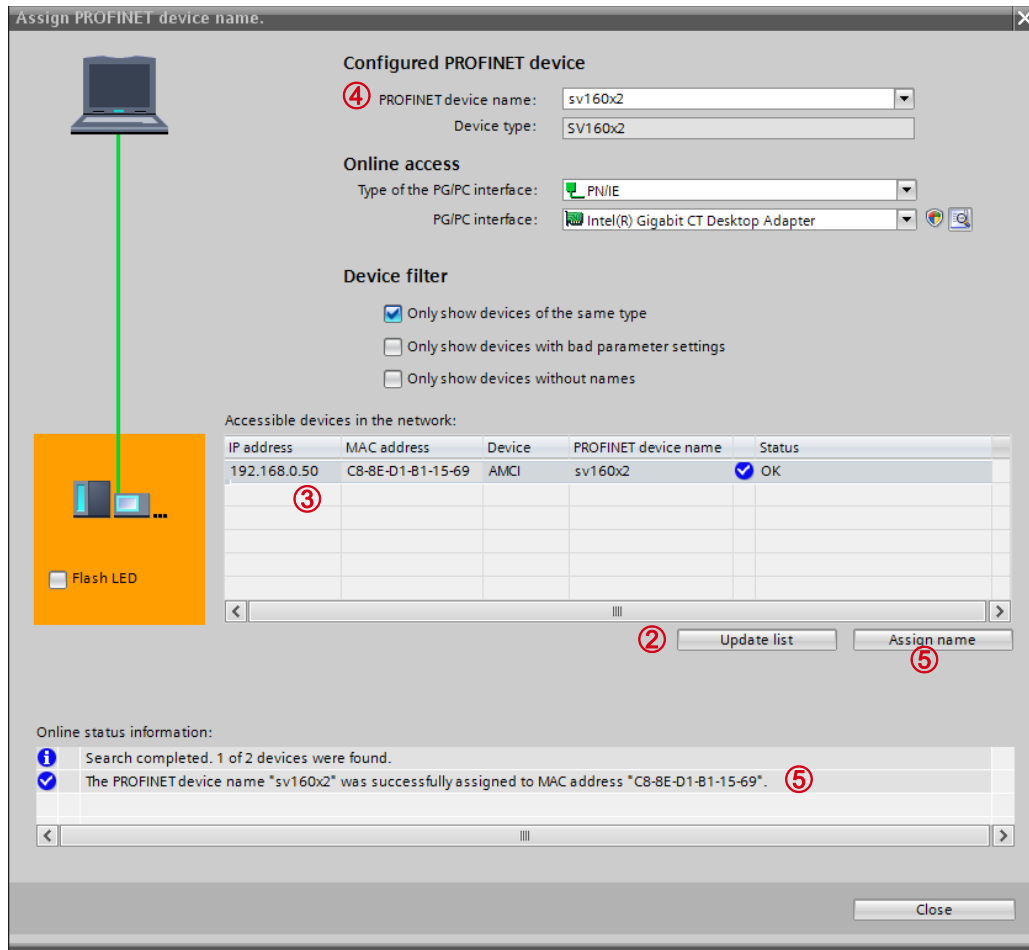

Figure T6.6 Setting SV Servo Device Name

6.8 Verify and Download the New Configuration

- 1) Continue by adding any remaining devices to your PROFINET network.
- 2) Compile and download the project to the CPU.

MRP Installations

At this point, the SV Servo is configured and ready to use. If you are using the unit in a redundant, ring based, network that uses the Media Redundancy Protocol (MRP), continue with the following instructions.

Media Redundancy Protocol (MRP) installations require that the SV Servo be installed in a ring topology. In these applications, both Ethernet ports are used when wiring the ring, daisy chaining from one unit in the ring to the next. The section below covers typical software configuration that must also be completed.

6.9 Configure the SV Servo as an MRC

The SV Servo functions as a Media Redundancy Client (MRC) in an MRP network.

- 1) Switch to Topology view and drag the additional connections between the appropriate ports.
- 2) Click on the SV Servo icon to select it. In the Inspector window, select *Advanced options* +> *Media redundancy*. Use the “MRP domain:” drop down menu to select the appropriate domain. Use the “Media redundancy role:” drop down menu to select “Client”.
- 3) Continuing in the Inspector window, select *Advanced options* +> *Port 1* +> *Port interconnection*. Under “Partner port:”, the partner port you assigned to the port when you drew the topology is shown. If you do not know which port will be the partner port in the actual installation, you can use the drop down menu to select “Any partner”.
- 4) If need be, repeat step 3 for Port 2 of the SV Servo.

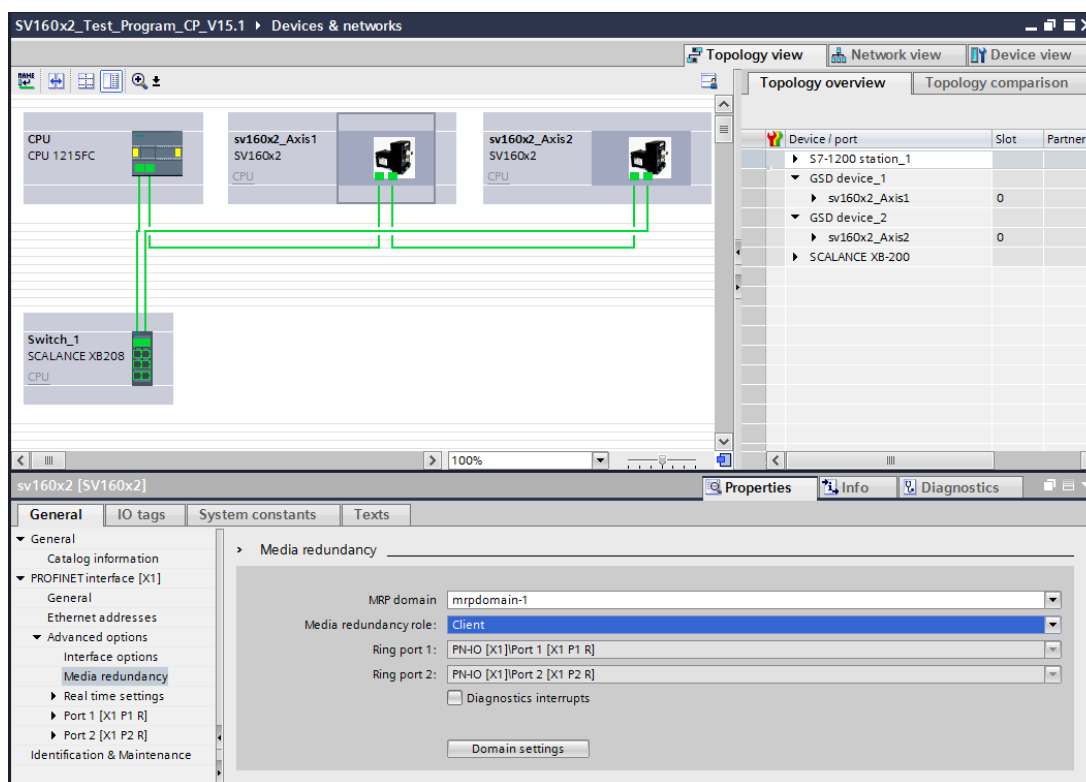

Figure T6.7 MRP Topology and Client Settings

- 5) Continue configuring the rest of the devices on the network before compiling the project and downloading it to the CPU.



ADVANCED MICRO CONTROLS INC.

20 GEAR DRIVE, TERRYVILLE, CT 06786 T: (860) 585-1254 F: (860) 584-1973

www.amci.com

LEADERS IN ADVANCED CONTROL PRODUCTS