

User Manual

1731H & 1732H Intelligent Resolver Input Modules

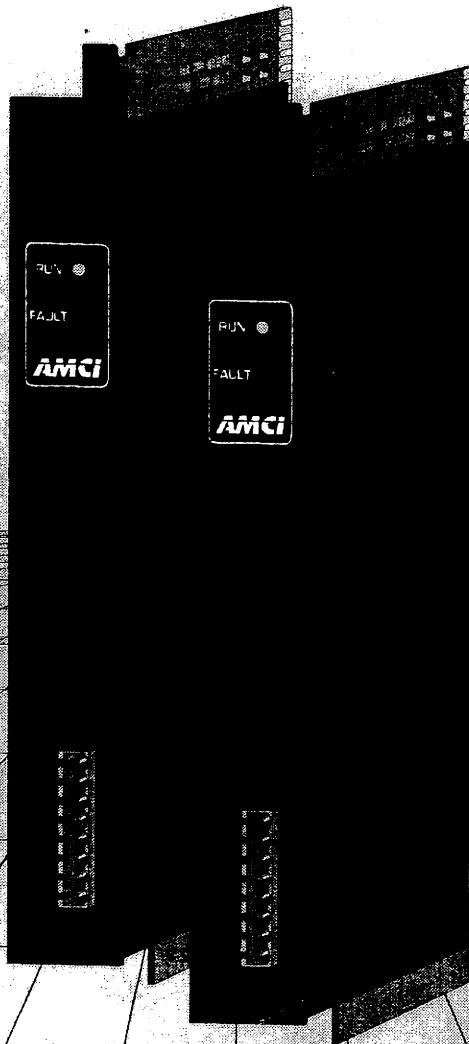

AMCI
Allen-Bradley
1771 I/O
Module

Manual: 940-07040

GENERAL INFORMATION

Important User Information

The products and application data described in this manual are useful in a wide variety of different applications. Therefore, the user and others responsible for applying these products described herein are responsible for determining the acceptability for each application. While efforts have been made to provide accurate information within this manual, AMCI assumes no responsibility for the application or the completeness of the information contained herein.

UNDER NO CIRCUMSTANCES WILL ADVANCED MICRO CONTROLS, INC. BE RESPONSIBLE OR LIABLE FOR ANY DAMAGES OR LOSSES, INCLUDING INDIRECT OR CONSEQUENTIAL DAMAGES OR LOSSES, ARISING FROM THE USE OF ANY INFORMATION CONTAINED WITHIN THIS MANUAL, OR THE USE OF ANY PRODUCTS OR SERVICES REFERENCED HEREIN.

Throughout this manual the following two notices are used to highlight important points.



WARNINGS tell you when people may be hurt or equipment may be damaged if the procedure is not followed properly.



CAUTIONS tell you when equipment may be damaged if the procedure is not followed properly.

No patent liability is assumed by AMCI, with respect to use of information, circuits, equipment, or software described in this manual.

The information contained within this manual is subject to change without notice.

Standard Warranty

ADVANCED MICRO CONTROLS, INC. warrants that all equipment manufactured by it will be free from defects, under normal use, in materials and workmanship for a period of [1] year. Within this warranty period, AMCI shall, at its option, repair or replace, free of charge, any equipment covered by this warranty which is returned, shipping charges prepaid, within one year from date of invoice, and which upon examination proves to be defective in material or workmanship and not caused by accident, misuse, neglect, alteration, improper installation or improper testing.

The provisions of the "STANDARD WARRANTY" are the sole obligations of AMCI and excludes all other warranties expressed or implied. In no event shall AMCI be liable for incidental or consequential damages or for delay in performance of this warranty.

Returns Policy

All equipment being returned to AMCI for repair or replacement, regardless of warranty status, must have a Return Merchandise Authorization number issued by AMCI. Call (860) 585-1254 with the model and serial numbers along with a description of the problem. A "RMA" number will be issued. Equipment must be shipped to AMCI with transportation charges prepaid. Title and risk of loss or damage remains with the customer until shipment is received by AMCI.

24 Hour Technical Support Number

24 Hour technical support is available on this product. For technical support, call (860) 583-7271. Your call will be answered by the factory during regular business hours, Monday through Friday, 8AM - 5PM EST. During non-business hours an automated system will ask you to leave a message, including the telephone number you can be reached at. The system will page one of two support engineers on call. Please include your product model number and a description of the problem in your message.

ADVANCED MICRO CONTROLS INC

ABOUT THIS MANUAL

Introduction

This manual explains the operation, installation, and programming of the 1731H and 1732H Resolver Interface Modules for the Allen-Bradley 1771 programmable controller systems. It is strongly recommended that you read the following instructions. If there are any unanswered questions after reading this manual, call the factory. An applications engineer will be available to assist you.

AMCI is a registered trademark of Advanced Micro Controls Inc.

The AMCI logo is a trademark of Advanced Micro Controls Inc.

PLC-2, PLC-3, and PLC-5 are registered trademarks of Allen-Bradley Company.

This product is licensed under patents and proprietary technology of Allen-Bradley Company, Inc.. Allen-Bradley Company, Inc. does not warrant or support this product in any manner.

Manuals at AMCI are constantly evolving entities. Your questions and comments on this manual and the information it contains are both welcomed and necessary if this manual is to be improved. Please direct all comments to: Technical Documentation, AMCI, 20 Gear Drive, Plymouth Industrial Park, Terryville CT 06786, or fax us at (860) 584-1973.

Revision Record

The following is the revision history for this manual. In addition to the information listed here, revisions will fix any known typographical errors and clarification notes may be added.

This manual, 940-07040, supersedes 173H-494M. It corresponds to software revision 2, PC Board revision H and was first released 1/30/1998. The software revision incorporates several new programmable features into the module. The hardware revision is a change over from through-hole to surface mount components. To determine whether or not this manual is for your module, the hardware revision is printed on the PC Board at the top of the module. If the board revision is less than 'H', use manual 173H-494M instead of this manual.

Past Manual Revisions

173H-494M: Corrected typographical errors. Still in use for modules with PC Board revision below revision H.

1731-993M: Initial release of the manual.

ABOUT THIS MANUAL

Notes

INTRODUCTION

This chapter serves as an introduction to the 1731H and 1732H modules. It highlights potential applications, compatible transducers, and all of the modules' features, including those added since the last revision.

Overview

The 1731H and 1732H modules are Allen Bradley 1771 I/O compliant cards that convert resolver signals to digital position and tachometer data that can be reported over the backplane. The 1731H can communicate with either block or single transfers. The 1732H communicates with block transfers. These modules eliminate the separate resolver decoder box, PLC input card, and associated wiring needed to bring the digital data into a PLC.

Like an absolute optical encoder, a resolver is a sensor that converts an angle into electrical signals. However, this is where the similarities end. The resolver is an analog device that does not contain sensitive components such as optics and electronics that may be damaged by severe environmental conditions. Also, the position resolution of a resolver is limited only by the electronics that decode its signals. When attached to a 1700H module, the resolver gives an absolute position value with up to ten bit position resolution over a six conductor cable.

A 1731H or 1732H application generally falls into one of two categories.

- **Rotary Application** – The resolver position directly correlates to an angular position on the machine. One example is monitoring a press ram. As the press cycles through one turn, the resolver position is used to monitor and control such functions as material feed and part blow-off.
- **Linear Application** – The resolver position correlates to a physical length. These applications can be either single turn or multi-turn. An example of a single turn application is a packaging machine where the resolver completes one turn for each product. Here the resolver position is used to control when glue is applied or when the package is cut to length. An example of a multi-turn application is monitoring the position of a load on either a track or a ball screw. In this type of application, linear position is translated to rotary position through either a wheel or gearing. The transducer must complete several rotations before the load travels the complete linear distance.

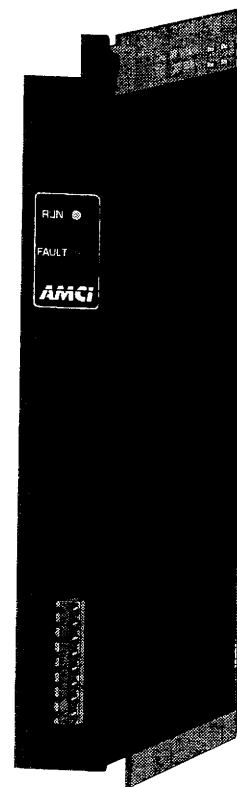

Figure 1.1
1731H Module



Overview (continued)

AMCI also has a line of cable reel transducers for use in linear applications. A cable reel transducer has a stranded stainless steel cable wrapped around a spring loaded drum. As the cable is pulled out of the transducer, the drum rotates, which in turn rotates the internal resolver. The cable is retracted by the force of the drums' spring. Distances of up to forty-five feet can be measured with these transducers.

The 1731H and 1732H modules are primarily intended for single turn applications. They can be used in multi-turn applications by using a cable reel transducer or by placing a gear ratio between the output shaft of the machine and the AMCI transducer. AMCI has a line of transducers with an internal (x):1 ratio for use in these applications. However, you must remember that the maximum number of counts remains fixed at 1,024 counts. If you need higher resolution, you can use a 1761H module. This module provide up to 4,096 counts *per turn* over a maximum of 180 turns. (737,280 counts max.)

Physically, the Series 1700H modules are single slot cards that have one or two resolver inputs, called transducer channels. In addition to the eight pin Transducer Input Connector, the front panel has two LED's that shows the modules' status.

All of the modules have programmable *Transducer Setup Parameters* that allow you to scale and adjust the position and tachometer data. Additional *Module Setup Parameters* define the type of attached transducer and the digital format of the position and tachometer data. To maintain compatibility with past versions of the module, some of these parameters can be set with jumpers. All of the parameters can be programmed over the backplane using either block or single transfers.

Since revision H of the PC board, the 1700H modules directly support Autotech transducers. The module does this by automatically adjusting the reference voltage to the Autotech level when the *Resolver Type* parameter is changed from the backplane. The reference voltage is the excitation signal sent to the resolver from the module.

AMCI also has a line of two slot modules for the 1771 I/O. These modules have from one to four transducer channels and an integral keyboard and display that allows you to setup the module and monitor position and tachometer data from the module. They also directly support Autotech transducers.

INTRODUCTION

AMCI Compatible Transducers

Table 1.1 lists the AMCI transducers that are compatible with the 1731H and 1732H modules.

Model	Shaft	Mount	Turns	Comments
RES-1	0.120"	Servo	1	NEMA 1, Size 11 Resolver
HT-6	0.188"	Front or Side	1	NEMA 13 RES-1 transducer
HT-20	0.625"	Front or Side	1	NEMA 13 heavy duty transducer
HT-20S	0.625"	Front or Side	1	HT-20 w/ side connector
HT-20K	0.625"	Front or Side	1	NEMA 4X HT-20 w/ Viton shaft seal
HT-20L	0.625"	Front or Side	1	NEMA 4X HT-20 w/ Nitrile shaft seal
HT-20C	0.625"	Front or Side	1	NEMA 4X stainless steel HT-20, Viton seal, conduit connector
H25FE	0.375"	Flange	1	NEMA 4, size 25, end connector
H25FS	0.375"	Flange	1	NEMA 4, size 25, side connector
H25SE	0.375"	Servo	1	NEMA 4, size 25, end connector
H25SS	0.375"	Servo	1	NEMA 4, size 25, side connector
HT-20-(x)	0.625"	Front	(x)†	HT-20 w/ internal (x):1 gear ratio
HTT-20-1	0.625"	Front	1	Redundant single turn resolvers
HTCR-9n-1	0.047" Cable	Foot	12"	Cable Reel Transducer, 12" span, 0.003" max. resolution, 45 ft stranded stainless cable standard.
HTCR-9n-6	0.047" Cable	Foot	76"	Cable Reel Transducer, 76" span, 0.010" max. resolution, 41 ft stranded stainless cable standard.
HTCR-9n-20	0.047" Cable	Foot	254"	Cable Reel Transducer, 254" span, 0.032" max. resolution, 41 ft stranded stainless cable standard.

Table 1.1 Compatible AMCI Transducers

† Available gear ratios are: 2:1, 2.77:1, 3:1, 4:1, 4.8:1, 5:1, 6:1, 7:1, 8:1, 10:1, 12:1, 13:1, 15:1, 16:1, 20:1, 24:1, 36:1, 40:1, 50:1, 60:1, 64:1, 100:1, 105:1, 150:1, and 250:1.

Other Compatible Transducers

In addition to AMCI transducers, the 1700h modules now directly support Autotech transducers. The Autotech models supported are:

- All SAC-RL100 Transducers. (Size 40, NEMA 13)
- All E6R and E7R-RL101 Transducers. (Size 25, NEMA 13)
- SAC-RL101-010 Transducer. (Size 11, NEMA 1)

You program the module for AMCI or Autotech transducers from the backplane. The module then sets the reference voltage for the resolver according to your selection. If you have a 1732H, both of the attached transducers must be either AMCI or Autotech. If you wish to bring both types of transducers into a single card, you must set the transducer type to AMCI and use an AMCI RM-3 Reference Module to connect the Autotech transducers.

The remainder of this chapter introduces the many programmable features of the modules. It also introduces backplane programming concepts that allows you to control the module from the processor.

Programmable Parameters

A 1700H module is configured by setting its programmable parameters. Parameters are broken into two groups.

- **Transducer Setup Parameters** – Three parameters that affect the position and tachometer data of each transducer. The 1732H module repeats these parameters for each transducer.
- **Module Setup Parameters** – Two parameters that set the type of resolvers attached to the card and the format of the position and tachometer data. There is only one of each of these parameters. They are not repeated for each transducer channel of the 1732H module.

Programmable parameters are stored in the modules nonvolatile memory. Therefore, you do not have to configure the module after every power up. Prior to hardware revision H of the module, the nonvolatile memory was EEPROM. This technology has the advantage of retaining programmed values for over 100 years. Its disadvantage is its limited number of write cycles, approximately ten thousand, before the memory will begin to fail.

With revision H, the nonvolatile memory has been changed to battery backed, non-volatile, static RAM (nvRAM). The battery in nvRAM is rated for ten years but the nvRAM has an unlimited number of write cycles. The nvRAM has the additional advantage of significantly decreasing the time needed to store new parameter values.

For backwards compatibility, jumpers exist on the board that allow you to set the number of counts per turn and the format of the data written to the processor. Once the module has been configured from the backplane, these jumper settings are ignored. If you are using this module in a system already designed for the older version of this card, you can use these jumpers and your software will work without modification.

Transducer Setup Parameters

Scale Factor

The Scale Factor sets the number of counts per turn of the resolver.

- The default Scale Factor is 360. This gives 1 degree resolution.
- The Scale Factor can be programmed to 180, 256, 360, 500, 512, 720, 1,000, or 1,024 counts per turn. The two Scale Factor parameters of a 1732H can be programmed to different values.



This parameter can also be set by a jumper to either 360 or 1,000. If you are using a 1732H, both Scale Factor parameters are set with this one jumper. If the module is programmed from the backplane, the state of the jumper is ignored.

INTRODUCTION

Transducer Setup Parameters (continued)

Count Direction

This new parameter sets the direction of transducer shaft rotation to increase the position count. *If the transducer cable is wired as specified in this manual* and the count direction is set to *positive*, the position count will increase with clockwise rotation (looking at the shaft). If the count direction is set to *negative*, the position count to increase with counter-clockwise rotation.

- The Count Direction default value is *positive*.



It is also possible to reverse the count direction by reversing two wires in the transducer cable. If you are installing this module as a replacement for an older module or on a machine that is a copy installation of a previous system, you will probably not need to set this parameter. Once the machine is setup, you can easily change this parameter if the position is increasing in the wrong direction.

Tachometer Response

This parameter sets the time between tachometer updates. The tachometer has a resolution of 1.0 RPM and a maximum speed of 5,000 RPM.

- The default value is 32 mSec between tachometer updates.
- This value can be set to 32 mSec or 120 mSec. The 32 mSec setting offers a quicker response to changes in transducer speed while the 120 mSec setting offers better speed averaging.
- If you are using a HT-20-(x) transducer, the speed reported by the module is not the speed of the transducers' input shaft. The speed reported IS (Actual Speed / 'x') RPM, where 'x' is the turns ratio of the transducer.

Module Setup Parameters

Resolver Type

The Resolver Type parameter is a new parameter that makes most Autotech transducers compatible with the 1731H and 1732H modules.

- The Resolver Type default value is AMCI.

If you have a 1732H and plan to use one AMCI and one Autotech resolver with the module, you must set the Resolver Type to AMCI. You will need an RM-3 Reference Module to interface the Autotech transducer with the card. Refer to Chapter 2, starting in pg. 18 for more information on installing and using Autotech transducers.

Module Setup Parameters (continued)

Data Format

This parameter allows you to choose the format of the position and tachometer data reported over the backplane. The choices are Binary or BCD. This parameter is included for PLC-2 users that require BCD data for PLC-2 math instructions. All other applications should choose Binary data format.



This parameter can also be set by a jumper to either Binary or BCD. Once the module is programmed from the backplane, the state of the jumper is ignored.

Backplane Programming

A 1731H module is programmed by writing a single word to it with either block or single transfers. The 1732H is programmed with a single word written with block transfers only. The Transducer Setup parameters are programmed one channel at a time. Therefore, two block transfer writes are needed to completely program a 1732H. When programming data is written with block transfers, it is acted upon immediately by the module. Because transfers are continuous in single transfer mode, programming changes are performed with a Programming Cycle that is initiated when the Transmit Bit in the output image table data makes a positive transition.

Programming Cycle

A Programming cycle consists of five steps.

- 1) Write the new single transfer data to the output image table with the Transmit bit set to one. The 1731H will not act on the new programming block until the Transmit bit makes a 0 → 1 transition.
- 2) Once the module is done with the programming data it will set any necessary error bits and the Acknowledge bit in its input image table word.
- 3) Once your ladder logic sees the Acknowledge bit is set, it should check for any programming errors.
- 4) Your ladder logic then responds to any errors and then resets the Transmit bit by writing 0000h in the output image table.
- 5) The module responds by resetting the Acknowledge bit. The Programming Cycle is now complete.

Resetting the Position Data

The position data can be reset to zero from the backplane. When the position is reset, the module calculates and stores an internal offset value that is added to the position data to bring it to zero.

The position data can be zeroed from the backplane without initiating a programming cycle. The modules do not allow you to program the module and zero the position data with one write to the module. Note that the internal offset is cleared after every programming cycle so you must program the module before resetting the position data.

INSTALLATION

This chapter gives information on configuring and installing a 1700H module. This information includes: installing the module in a 1771 I/O chassis, installing transducers and transducer cabling, and the different states of the front panel LED's to aid in troubleshooting.

Configuration Jumpers

In order to maintain backwards compatibility, the modules can be configured with three jumpers on the board. The first jumper is only used by the 1731H module and is located at the top of the module. It sets the module to use either single or block transfers. The other two jumpers are located inside the module and sets the Scale Factor and Data Type parameters. Figure 2.1 shows the location and purpose of the jumpers.

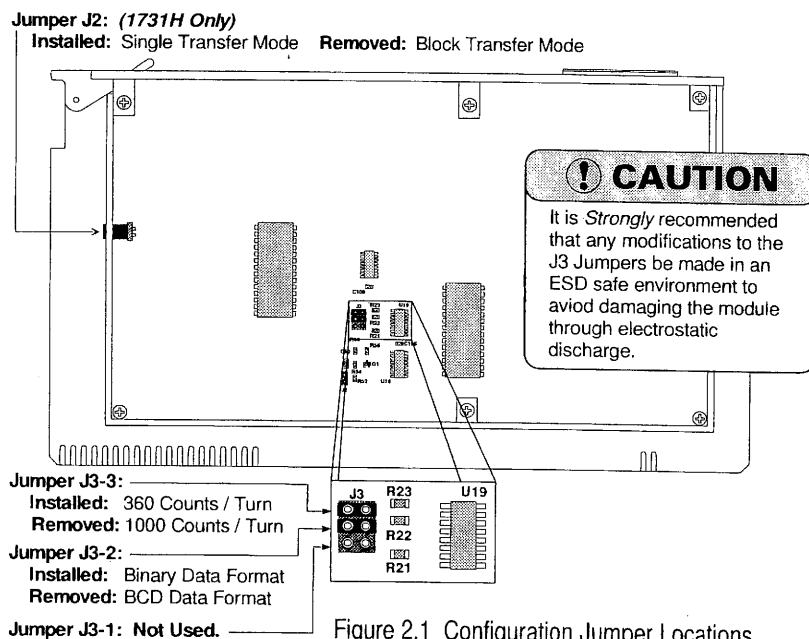

NOTE

If the module can be configured for your application with just these jumpers, you can avoid programming the module from the backplane. If you have to program even one of the parameters from the backplane, do not open the module and change the two J3 jumpers. The state of these jumpers is ignored after the module is programmed from the backplane.



Power Requirements

The 1731H and 1732H modules draw power from the I/O chassis +5Vdc supply. Add the power requirements of the module to the power requirements of all other modules in the chassis when sizing the chassis power supply.

Module Number	1731H	1732H
Maximum Current Draw	385 mA	415 mA
Maximum Power Draw	1.93 W	2.08 W

Table 2.1 Backplane Power Draw

Installing the Module

A 1731H or 1732H module can be installed in any open slot in the I/O chassis with the following restrictions:

- ▶ 1731H modules configured for single transfers must be installed in a chassis using 1-slot or ½-slot addressing.
- ▶ When the 1731H or 1732H module is configured for block transfers and the chassis is configured for 2-slot addressing, 16 point I/O modules cannot be installed in the adjacent slot.
- ▶ When the 1731H or 1732H module is configured for block transfers and the chassis is configured for 1-slot addressing, 32 point I/O modules cannot be installed in the adjacent slot.



When using a 1731H or 1732H module in a remote I/O chassis, the I/O Adapter must be a 1771-ASB, Series B, Firmware Rev. F, or later. A remote I/O adapter that has an earlier Series or Firmware revision may not work properly with the modules.



Remove system power before removing or installing any module in an I/O chassis. Failure to observe this warning may result in damage to the module's circuitry and/or undesired operation with possible injury to personnel.

Keying Bands

Plastic keying bands can be inserted into the top backplane connector to prevent the insertion of other modules. Insert the bands between the following pins:

- ▶ Pins 28 and 30
- ▶ Pins 32 and 34.

INSTALLATION



Transducer Input Connector

The Transducer Input Connector has eight contacts. The AMCI part number for the mating connector is MS-8. The Phoenix Contact *catalog* number for the mating connector is MSTB2.5/8-ST-5.08 while its *part* number is 1757077.

Figure 2.2 shows the connector pin out to industry standard wire designations. Cabling information for AMCI and Autotech transducers is given in the following sections of this chapter.

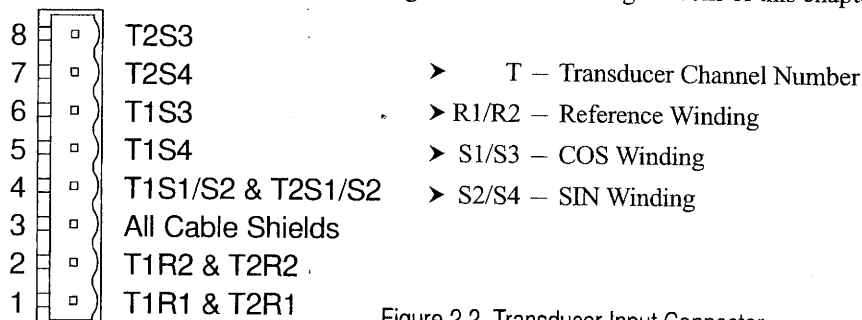

Figure 2.2 Transducer Input Connector

Transducer Cable Installation

Pre-assembled and tested cables are available from AMCI. The 1731H uses the C1T(x) cable ('x' equals length in feet), while the 1732H uses the C2T(x) cable. If you are making your own cables, connectors can be ordered from AMCI. The mating connector for the Transducer Input Connector is the MS-8, and the mating connector for AMCI transducers is the MS-16.

NOTE

- 1) Resolvers are low voltage, low power devices. If you are using A-B guidelines for cabling installation, treat the transducer cable as a Category 2 cable. It can be installed in conduit along with other low power cabling such as communication cables and low power ac/dc I/O lines. It cannot be installed in conduit with ac power lines or high power ac/dc I/O lines. Refer to the *Allen Bradley Programmable Controller Grounding and Wiring Guidelines* manual, Publication number 1770-4.1 for more information.
- 2) The shields of the transducer cable must be grounded at the module *only!* When installing the cable, treat the shield as a conductor. Do not connect the shield to ground at any junction box or the transducer. This will eliminate ground loops that could damage the module or PLC.



INSTALLATION

Transducer Wiring Diagrams

C1T-(x) Wiring Diagram (1731H)

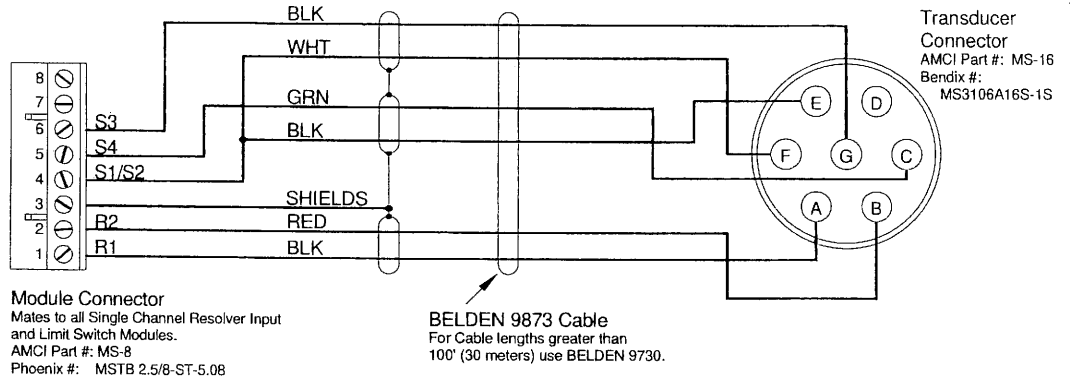

Figure 2.3 C1T-(x) Wiring Diagram

C2T-(x) Wiring Diagram (1732H)

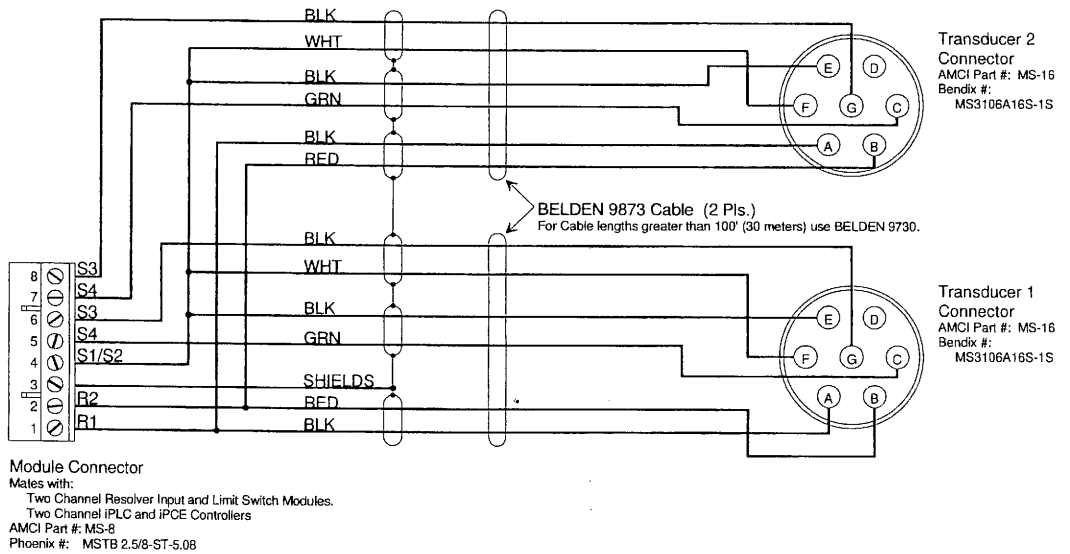
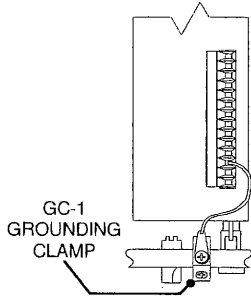

Figure 2.4 C2T-(x) Wiring Diagram

INSTALLATION



GC-1 Grounding Clamp



The shield of the transducer cable must be attached to the chassis with a Grounding Clamp (AMCI part number GC-1). This guarantees a low impedance path to ground for any EMI radiation that may be induced into the cable. The drain wire from the Grounding Clamp must be connected to pin 3 of the MS-8 Transducer Input Connector. The grounding clamp package included with the module has additional installation instructions.

Figure 2.5 GC-1 Clamp

AMCI Transducer Outline Drawings

AMCI offers a broad line of resolver based transducers for use with the 1731H and 1732H modules. Outline drawings for selected transducers are available on the following pages. Below are listed the transducers that do not have their outline drawings included with this manual. Contact AMCI if you need one of these outline drawings. They will be faxed to you upon request.

- RES-1
- HT-6
- HT-20C
- HTCR Cable Reel Transducers

HT-20: Anodized Aluminum Body, Steel Shaft, NEMA 13

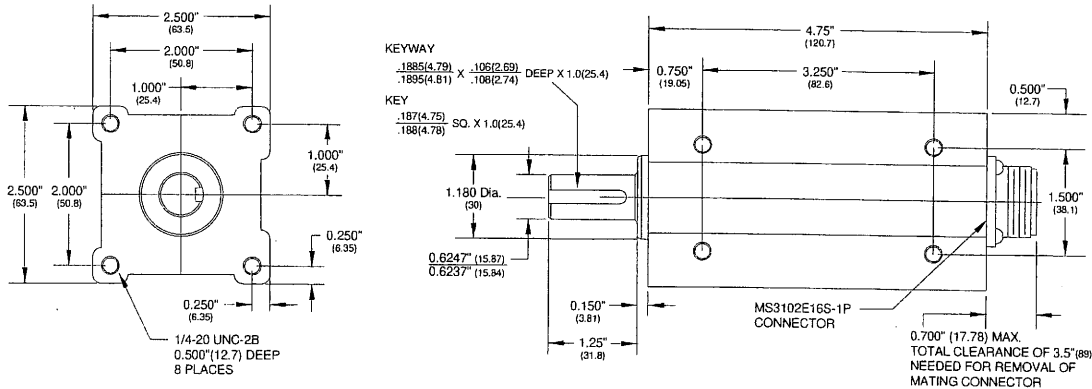

Figure 2.6 HT-20 Outline Drawing



AMCI Transducer Outline Drawings (continued)

HT-20S: Anodized Aluminum Body, Steel Shaft, NEMA 13

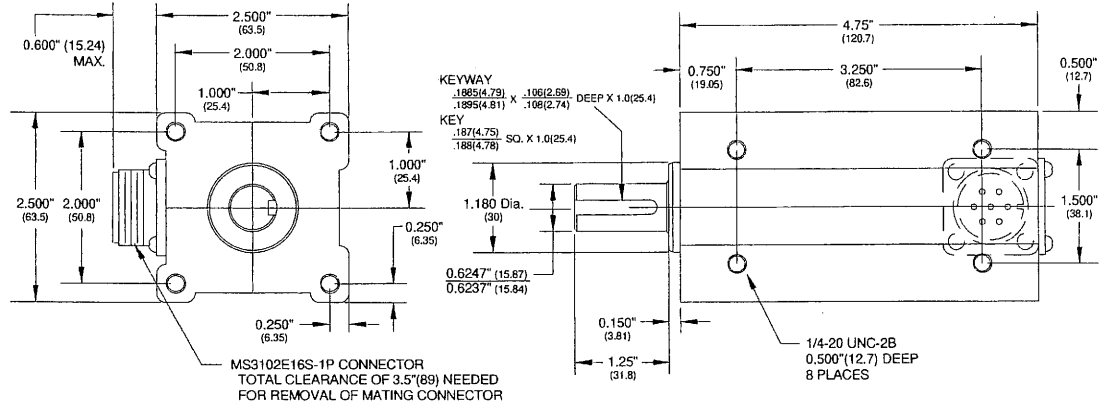

Figure 2.7 HT-20S Outline Drawing

HT-20K/L Hard Coat Anodized Aluminum Body, Stainless Steel Shaft, NEMA 4X

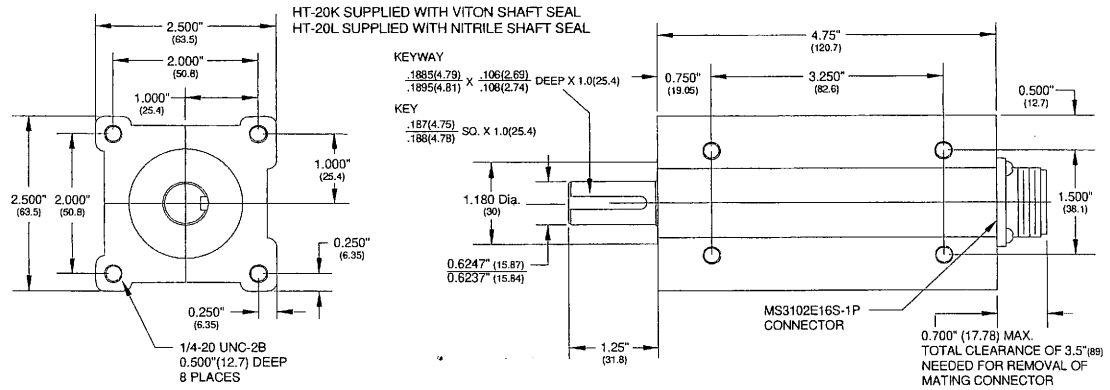

Figure 2.8 HT-20K/L Outline Drawing

INSTALLATION



AMCI Transducer Outline Drawings (continued)

H25FE & H25SE: Anodized Aluminum Body, Steel Shaft, NEMA 4

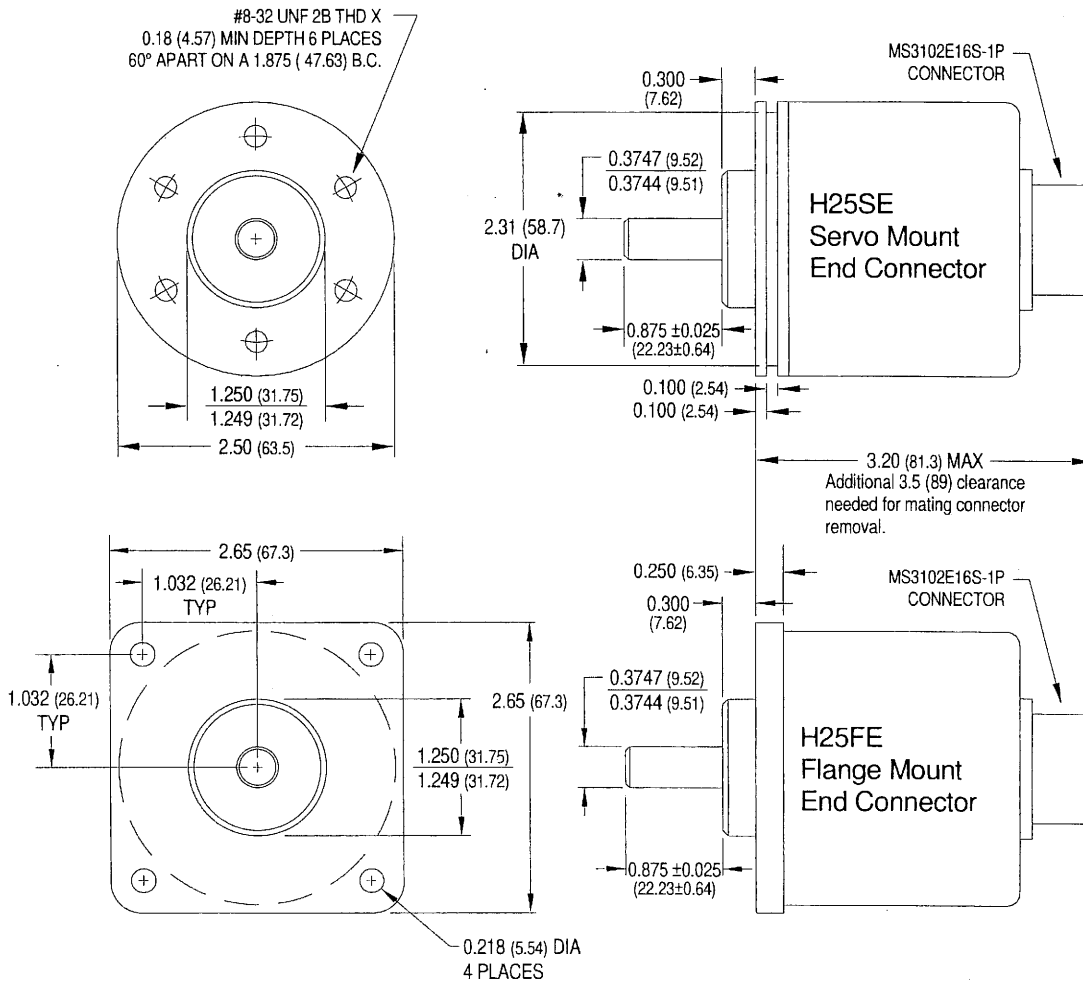

Figure 2.9 H25FE & H25SE Outline Drawing



INSTALLATION

AMCI Transducer Outline Drawings (continued)

H25FS & H25SS: Anodized Aluminum Body, Steel Shaft, NEMA 4

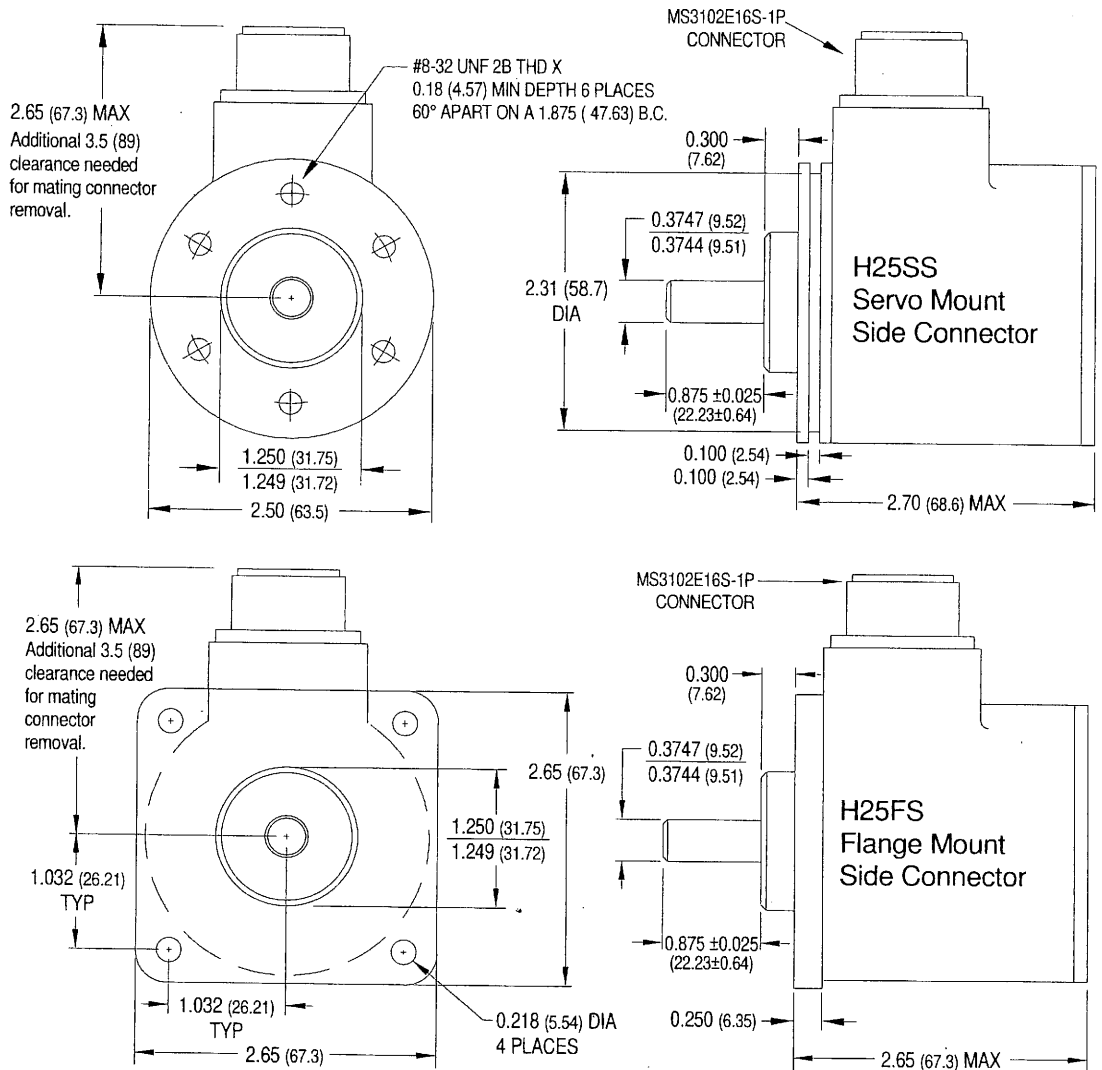

Figure 2.10 H25FS & H25SS Outline Drawing

INSTALLATION



AMCI Transducer Mounting

All AMCI resolver based transducers are designed to operate in the industrial environment and therefore require little attention. However, there are some general guidelines that should be observed to ensure long life.

- ▶ Limit transducer shaft loading to the following maximums:

	Radial Load	Axial Load
All HT-20 Transducers	100 lbs. (445 N)	50 lbs. (222 N)
All H25 Transducers	30 lbs. (133 N)	15 lbs. (66.7 N)
All Other Transducers	4 lbs. (17.8 N)	2 lbs. (8.9 N)

Table 2.2 Transducer Bearing Loads

- ▶ Minimize shaft misalignment when direct coupling shafts. Even small misalignments produce large loading effects on front bearings. It is recommended that you use a flexible coupler whenever possible.

Transducer Specifications

The following table contains mechanical and environmental specifications for all of the AMCI rotary transducers that are compatible with the 1731H and 1732H. Contact AMCI if you require the specifications for the cable reel transducers. They will be faxed to you upon request.

Specification	All HT-20's	All H25's	HT-6
Shaft Diameter	0.625"	0.375"	0.188"
Radial Shaft Loading	400 lbs. Max.	40 lbs. Max.	8 lbs. Max.
Axial Shaft Loading	200 lbs. Max.	20 lbs. Max.	4 lbs. Max.
Starting Torque	8 oz.in. @ 25°C	1.5 oz.in. @ 25°C	0.5 oz.in. @ 25°C
Moment of Inertia	20 oz-in-sec ²	4 oz-in-sec ²	2.1 x 10 ⁻⁴ oz-in-sec ²
Weight	4 lbs.	1 lb.	0.7 lb.
Enclosure	NEMA 13 or 4X	NEMA 4	NEMA 13
Environmental (All Transducers)			
Operating Temp -20 to 125°C	Shock 50G's for 11 mSec		Vibration 5 to 2000 Hz @ 20 G's

Table 2.3 Transducer Specifications



INSTALLATION

Transducer Specifications (continued)

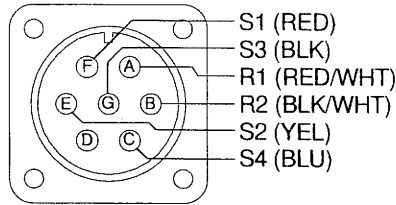

All of the AMCI transducers that are compatible with the 1731H and 1732H modules have the same connector. Figure 2.11 is the connector pin out to the industry standard wire designations.

Figure 2.11 Transducer Connector Pin Out

Autotech Transducer Installation

Transducer Mounting

The 1731H and 1732H modules directly support Autotech SAC-RL100, E6R and E7R-RL101, and SAC-RL101-010 transducers. Refer to Autotech Controls literature for dimensional drawings and mounting recommendations.

Transducer Wiring

Table 2.4 is a wiring table for all supported Autotech transducers. The table cross references AMCI wire color, resolver designations, and Autotech connector pin-out.

AMCI Wire Color	Resolver Designation	SAC-RL101-010 Wire Colors	SAC-RL100-010 Terminals	SAC-RL100-Gxxx Terminals	Autotech MS Conn.
BLK/RED ¹	R1	RED/WHT ²	R1(RL)	1	F
RED	R2	YEL/WHT ²	R2(RH)	2	E
WHT	S1	RED	S1	3	D
BLK/WHT ¹	S3	BLK	S3	4	C
BLK/GRN ¹	S2	YEL	S2	5	B
GRN	S4	BLU	S4	6	A

1: Denotes black wire of black and colored wire pair.

2: Denotes colored wire with white stripe.

Table 2.4 Autotech Transducer Wiring



Do not, *under any circumstances*, connect the shields of the transducer cable to the earth ground connection of the transducer. This connection could form a ground loop that could damage the module or PLC. The earth ground connection on the MS style connectors is pin G. The earth ground connection on the screw terminal transducers is a green screw.

INSTALLATION



Using AMCI and Autotech Transducers Together

If you are connecting AMCI and Autotech transducers to the same 1700H module, you must set the resolver type parameter to AMCI and use a RM-3 reference module to adjust the reference to the Autotech resolvers. The figure below shows an outline drawing and connection diagram for the RM-3. The RM-3 should be mounted as close to the 1700H's transducer input connector as possible.

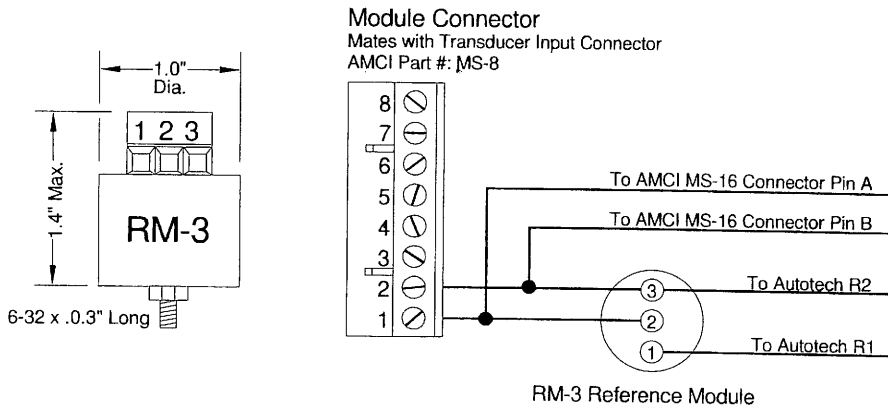

Figure 2.12 RM-3 Outline Drawing and Wiring Diagram



Indicator LED Patterns

Once the system is installed and power is applied, the two Indicator LED's on the front panel indicate the operating status of the module. Table 2.5 lists the five different patterns and their meaning.

RUN LED	FAULT LED	COMMENT
OFF	ON	MODULE FAULT The parameters stored in the nvRAM are corrupted. This fault is cleared by setting the Clear Errors bit in the data written down to the module. If the error clears, the parameters are set to their default values. If the error still exists, the module must be returned for repair. If this error occurs on every power up, but can be cleared, the lithium battery in the nvRAM is discharged and the module must be returned for repair.
OFF	FLASHING	REFERENCE ERROR The module stores adjustment constants in the nvRAM memory that allow it to set the reference voltage for either AMCI or Autotech transducers. This error occurs when these adjustment constants are corrupted. When a working transducer is attached, the module recalculates the constants and stores them in nvRAM. If this error exists with a working transducer attached to the module, cycle power. If the error still exists, the module must be returned for repair.
FLASHING	OFF	ADJUSTING REFERENCE VOLTAGE This LED pattern indicates that the module is recalculating the reference voltage constants. When the calculations are complete, the indicator pattern will change to <i>Reference Error</i> or <i>Module OK</i> .
ON	FLASHING	TRANSDUCER FAULT One, or both, transducers are not operating properly. There are six major causes of this fault. <ul style="list-style-type: none">➤ Broken or intermittent transducer cable➤ Non-compatible transducer➤ Improper wiring of the transducer cable➤ Improper installation of the transducer cable➤ Faulty transducer➤ Faulty module Transducer faults are self-clearing. If a fault is caused by a burst of electrical noise or an intermittent connection, the fault will clear itself.
ON	OFF	MODULE OK The module is operating without any faults. Transducers are operating properly.

Table 2.5 Indicator LED's



SINGLE TRANSFER DATA FORMAT

The 1731H module is factory configured to transfer its position data to the processor with single transfers. (See Jumper Configurations, pg. 9.) This chapter gives the data formats for the single transfer data and tells you how to program the 1731H using single transfers.

Backwards Compatibility

Backplane programming additions were added to the 1731H modules with the revision H. However, these modules are completely backwards compatible with older revision modules. You can use a revision H+ 1731H in a system whose ladder logic was written for an earlier revision module without modifying your ladder logic.

If you install a pre-revision H 1731H into a system whose ladder logic was written for the newer modules, the system will work without errors, but perhaps not as expected. The older 1731H will reset its position data to zero when commanded and ignore all programming data written to it. If your system depends on the new programmable features for operation, then you must carefully determine if your ladder logic can be modified to accommodate a pre-revision H module in your system.

Single Transfer Definition

Single transfers are used by most non-intelligent I/O cards such as DC input or output cards. Single transfers move a single unit of data over the backplane. This transfer occurs between the module and the processor's input or output image table. Single transfers occur automatically every scan and can occur during a program scan with the use of Immediate Input and Immediate Output Instructions. 1731H modules accept and transmit 16 bits of data using single transfers.

The advantage of single transfers is ease of use. You do not have to enter any instructions into your ladder logic to communicate with the module. You only have to access the correct word in the input and output image tables. The disadvantage of using single transfers is that you do not have access to the tachometer data of the module



SINGLE TRANSFER DATA FORMAT

Addressing a 1731H Single Transfer Module

2-Slot Addressing

Because of limitations of the A-B TIC chip used as the 1731H backplane interface, you cannot install a 1731H in an I/O chassis configured for 2-slot addressing.

1-Slot Addressing

The 1731H uses the input and output image table word assigned to the slot. Because of this, 32 point I/O modules cannot be installed in the slot adjacent to the 1731H. The PLC-5 input image table address is I:rrg and the PLC-5 output image table address is O:rrg, where 'rr' is the rack number and 'g' is the group number.

1/2-Slot Addressing

The 1731H uses the even numbered input and output image table word assigned to the slot. The PLC-5 input image table address is I:rrg and the PLC-5 output image table address is O:rrg, where 'rr' is the rack number and 'g' is the group number. Note that 'g' equals 0, 2, 4 or 6.

Output Image Table Data Format

Figure 3.1 shows the format of the data that can be written to the 1731H in single transfer mode. The word contains the bits to perform two separate operations:

- Reset the position value to zero.
- Program all of the module parameters.

Six bits in the word are defined as zero and reserved. If you set one of these bits and attempt to program the module, it will respond with a programming error.



Programming the module and resetting the position value is considered two separate operations by the module and cannot be performed at the same time. In order to maintain backwards compatibility, resetting the position value has precedence over programming the module. If you attempt to perform both operations at the same time, you will only reset the position value. When the Reset bit makes a 0→1 transition to reset the position value, all other bits in the word are ignored.

Output Image Table Format

Octal	17	16	15	14	13	12	11	10	07	06	05	04	03	02	01	00
Hex	15	14	13	12	11	10	09	08	07	06	05	04	03	02	01	00
Word 0	TRMT	0	0	0	ClrErr	DType	RType	TR	CDir	SF	0	0	0	RSet1		

Figure 3.1 Output Image Table Data

SINGLE TRANSFER DATA FORMAT



Output Image Table Data Format (continued)

Bit Values

RSet1: Reset Transducer 1: When this bit makes a 0→1 transition, the position value is reset to zero. This is accomplished by calculating an internal position offset that is applied to the resolver position. When you program the module, the internal offset is cleared. Therefore, if you have reset the position and then program the module, you must re-zero the position. Attempting to reset the position data while there is a transducer fault will have no effect, and will not generate an error message.

The remaining bits in the word are used to program the module. Remember that you cannot program the module and reset the position value at the same time. All programming data is ignored when the Rset1 bit makes a 0→1 transition.

SF: Scale Factor: These three bits define the number of counts per turn. Table 3.1 gives the bit values and the associated Scale Factor value.

Bit 6	Bit 5	Bit 4	Scale Factor
0	0	0	180 counts per turn
0	0	1	256 counts per turn
0	1	0	360 counts per turn
0	1	1	500 counts per turn
1	0	0	512 counts per turn
1	0	1	720 counts per turn
1	1	0	1,000 counts per turn
1	1	1	1,024 counts per turn

Table 3.1 Scale Factor Values

CDir: Count Direction: This bit programs the Count Direction parameter. *If the transducer cable is wired as specified in this manual* and this bit is reset to zero, the position value will increase with clockwise rotation (looking at the shaft). If this bit is set to one, the position count to increase with counter-clockwise rotation.

TR: Tachometer Response: When this bit is reset to zero, the Tachometer Response parameter is set to 120 mSec. When this bit is set to one, the Tachometer Response parameter is set to 32 mSec.

RType: Resolver Type: When this bit is reset to zero, the Resolver Type parameter is set to AMCI. When this bit is set to one, the Resolver Type parameter is set to Autotech.

Dtype: Data Type: When this bit is reset to zero, the position value is sent to the processor in binary format. When this bit is set to one, the position value is sent to the processor in BCD format.



SINGLE TRANSFER DATA FORMAT

Output Image Table Data Format (continued)

Bit Values (continued)

ClrErr: Clear Errors: When this bit is set to one, the module will clear any programming errors and attempt to clear a nvRAM error if one exists. Setting this bit will not clear a reference error. Reference errors can only be cleared by attaching a working transducer to the module.

TRMT: Transmit bit: A 0→1 transition on this bit initiates a Programming Cycle if the Rset1 does not make a 0→1 transition at the same time. Changes to programming are only accepted during a Programming Cycle.

Programming Cycle

Changes to a 1731H's programming are accomplished through a Programming Cycle. Two bits control the cycle. They are the Transmit bit and the Acknowledge bit. A Programming cycle consists of five steps.

- 1) Write the new single transfer data into the output image table with the Transmit bit set to one. The 1731H will not act on the new programming block until the Transmit bit makes a 0 → 1 transition.
- 2) Once the module is done with the programming data it will set any necessary error bits and the Acknowledge bit in its input image table word.
- 3) Once your ladder logic sees the Acknowledge bit is set, it should check for any programming errors.
- 4) Your ladder logic should then respond to any errors and then resets the Transmit bit by writing 0000h in the output image table.
- 5) The module responds by resetting the Acknowledge bit. The Programming Cycle is now complete.

Sample ladder logic is given at the end of the chapter.

Input Image Table Data Format

The format of the input image table data is given in figure 3.2. The position data is transmitted in binary or BCD format and is stored in the lower bits of the word. The two most significant bits of the word are used to transmit error information to the processor.

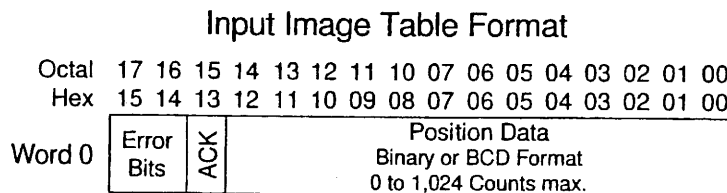

Figure 3.2 Input Data Format

SINGLE TRANSFER DATA FORMAT

Input Image Table Data Format (continued)

Bit Values

Position Data: The position data is stored in the least significant bits of the word. The number of bits used is a maximum of nine when transmitted in binary or a maximum of thirteen when transmitted in BCD.

ACK: Acknowledge Bit: This bit is set to acknowledge the acceptance of new programming data. To clear this bit, reset the Transmit bit in the output image table word. The module will then reset the Acknowledge bit.

Error Bits: These two bits report to the processor any programming or setup errors with the module. When either one of these bits is set, the position data equals zero. Table 3.2 lists the combinations of these bits and their meaning.

Bit 17	Bit 16	Error
0	0	No Error: Position data transmitted in the word.
0	1	Programming Error: One of the reserved bits in the programming word was set. These bits must equal zero. To clear a programming error, you must reprogram the module with the Clear Errors bit set.
1	0	Transducer or nvRAM Error: There is a transducer fault or the data in the nvRAM is corrupted. You can check the Indicator LEDs' on the front panel to determine the exact error. A transducer fault will clear itself once a working transducer is properly attached to the module. In order to clear a nvRAM error, you must reprogram the module with the Clear Errors bit set. If a nvRAM error cannot be cleared, or if the error occurs on every power up, the module must be returned for repair. Refer to the inside front cover for information on contacting AMCI.
1	1	Reference Error: The reference adjustment constants in the nvRAM are corrupted. The only way to clear this error is to properly attach a working transducer to the module. If the error does not clear, contact AMCI for assistance. Refer to the inside front cover for information on contacting AMCI.

Table 3.2 Error Bit Values



SINGLE TRANSFER DATA FORMAT

Sample Program

The following sample ladder logic shows how to program a module using single transfers and shows you how to mask the error and Acknowledge bits off the position data.

```
Rockwell Software Company
6200 Series Software
PLC-5 Programming Terminal Software
Release 5.21
Program Listing Report

1731H single transfer example program
Mon Mar 16, 1998 - 3:57:05 pm

File: C:\IPDS\ARCH\PLC5\1731HEX

REPORT OPTIONS
Page Width: 80
Page Length: 66
Graphics Capabilities: NO
Right Power Rail: YES
Address Display: SYMBOL
Address Comments: YES
Rung Comments: YES
Output Cross Reference: NO
Ladder Cross Reference: NONE
Starting Rung: 2:0
Ending Rung: 999:32767
Formatting Commands: ACTIVE
```

SINGLE TRANSFER DATA FORMAT



Sample Program (continued)

1731H single transfer example program Mon Mar 16, 1998 Page 1
 Program Listing Report PLC-5/11 File 1731HEX Rung 2:0

Rung 2:0
 If both of the 1731H error bits are not set, move through a mask the current position data to address N7:10. The mask value removes both the error bits, and the Acknowledge bit from the 1731H data. Please note, if either of these error bits are set, the data contained in address N7:10 will not change until the errors have been cleared.

1731H upper error bit I:000	1731H lower error bit I:000		1731H copied position data
] / [-----] / [-----]			+MVM-----+
17	16		+MOVE WITH MASK+
			Source I:000
			312
			Mask 1FFF
			Destination N7:10
			0
			+-----+

Rung 2:1
 Manually set bit N7:0/0 to cause the 1731H module's single transfer position to be reset to zero. Bit O:000/0 will only be active for one scan because of the one shot instruction in the rung. Bit N7:0/0 must be manually reset before another zero operation can occur.

manually set to zero 1731H position N7:0	manually set to 1731H program N7:0	one shot command for zero operation B3	set to zero 1731H position O:000
] / [-----] / [-----]		[ONS]	()
0	1	0	00

Rung 2:2
 Manually set bit N7:0/1 to program the 1731H module in single transfer mode. The data value of 112, bits 4, 5, and 6 set, programs the Scale Factor to its maximum value of 1024. After the data has been sent to the module, Transmit Bit O:000/17 is set to initiate the transfer.

manually set to zero 1731H position N7:0	manually set to 1731H program N7:0		data to program 1731H module
] / [-----] / [-----]			+MOV-----+
0	1		+MOVE+
			Source 112
			Destination O:000
			112
			+-----+
			1731H transmit bit
			O:000
			()
			17

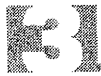

Sample Program (continued)

1731H single transfer example program Mon Mar 16, 1998 Page 2
Program Listing Report PLC-5/11 File 1731HEX Rung 2:3

Rung 2:3
After being programmed in single transfer mode, the 1731H module will set
ACKnowledge bit I:000/15 to indicate that the data has been accepted. The
following rung unlatches bit N7:0/1, which was used to initiate the transfer.
The programming cycle is now complete.

1731H ACK bit I:000 -----] [----- 15	manually set to program 1731H N7:0 (U)----- 1
Rung 2:4 ----- [END OF FILE] -----	

BLOCK TRANSFER DATA FORMAT

The 1732H transfers its data to the processor with block transfers. The 1731H module is factory configured to transfer its data to the processor with single transfers. To use the 1731H as a block transfer module, you must change a jumper. (See Jumper Configurations, pg. 9.) This chapter gives the data formats for the block transfer data and tells you how to program the module using block transfers. This chapter assumes that you are using a PLC-5. If you are using a PLC-2 or PLC-3 and need assistance, contact AMCI.

Backwards Compatibility

Backplane programming additions were added to the 1731H and 1732H modules with the revision H. However, these modules are completely backwards compatible with older revision modules. You can use a revision H+ module in a system whose ladder logic was written for an earlier revision module without modifying your ladder logic.

If you install a pre-revision H module into a system whose ladder logic was written for the newer modules, the system will work without errors, but perhaps not as expected. The older module will reset its position data to zero when commanded and ignore all programming data written to it. If your system depends on the new programmable features for operation, then you must carefully determine if your ladder logic can be modified to accommodate a pre-revision H module in your system.

Block Transfer Definition

Block Transfers are used by most intelligent I/O cards. Block Transfers move a block of up to sixty-four words over the backplane at one time. This transfer occurs only if you enter a block transfer instruction into your ladder logic. Block Transfer Write (BTW) instructions transfer data from the processor to the module. Block Transfer Read (BTR) instructions transfer data from the module to the processor. Both the 1731H and 1732H accept a single word for programming the module with BTW instructions. The 1731H transfers two words with the BTR instruction while the 1732H transfers four words.

The advantages of Block Transfers are that it can transfer more than two words of data at one time, giving you access to position and tachometer data. You can also use a block transfer module in a chassis configured for 2-slot addressing. The disadvantage of using block transfers is that you must enter block transfer instructions and associated logic into your ladder logic program.

4

BLOCK TRANSFER DATA FORMAT

BTW Data Format

Figure 4.1 shows the format of the data that can be written to a 1731H or 1732H with a block transfer write. The word contains the bits to perform two separate operations:

- Reset the position value(s) to zero.
- Program all of the module parameters. The transducer input channels are programmed one at a time. The 'Channel Number' bit defines which transducer input channel is being programmed.

Four bits in the word are defined as zero and reserved. If you set one of these bits and attempt to program the module, it will respond with a programming error.

NOTE 

Programming the module and resetting the position value(s) are considered two separate operations by the module and cannot be performed at the same time. In order to maintain backwards compatibility, resetting the position value(s) has precedence over programming the module. If you attempt to program the module and reset the position(s) at the same time, you will only reset the position value(s). When you set one or both of the bit to reset the position value(s), all other bits in the word are ignored.

BTW Data Format

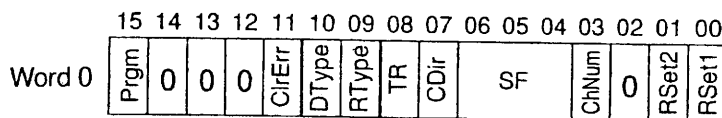

Only read when 'ChNum' equals 0.

Figure 4.1 Block Transfer Write Data

Bit Values

- RSet1: Reset Transducer 1: When a BTW occurs and this bit is set, the position value for transducer 1 is reset to zero. This is accomplished by calculating an internal position offset that is applied to the resolver position. When you program the module, the internal offset is cleared. Therefore, if you have reset the position and then program the module, you must re-zero the position. Attempting to reset the position data while there is a transducer fault will have no effect, and will not generate an error message.
- RSet2: Reset Transducer 2: (1732H only. A 1731H must have this bit equal to zero.) When a BTW occurs and this bit is set, the position value for transducer 2 is reset to zero. You can reset both transducers with one BTW. See the description of the RSet1 bit for more information.

BLOCK TRANSFER DATA FORMAT



BTW Data Format (continued)

Bit Values (continued)

The remaining bits in the word are used to program the module. Remember that you cannot program the module and reset the position value(s) at the same time. All programming data is ignored when RSet1 and /or RSet2 are set.

ChNum: Channel Number: This bit defines which transducer channel is programmed with the BTW. When this bit equals zero, channel 1 is programmed. When this bit equals one, channel 2 is programmed. You must leave this bit zero when programming a 1731H. Also, the Resolver Type and Data Type parameters are only programmed when this bit equals zero.

SF: Scale Factor: These three bits define the number of counts per turn. Table 4.1 gives the bit values and the associated Scale Factor value.

Bit 6	Bit 5	Bit 4	Scale Factor
0	0	0	180 counts per turn
0	0	1	256 counts per turn
0	1	0	360 counts per turn
0	1	1	500 counts per turn
1	0	0	512 counts per turn
1	0	1	720 counts per turn
1	1	0	1,000 counts per turn
1	1	1	1,024 counts per turn

Table 4.1 Scale Factor Values

CDir: Count Direction: This bit programs the Count Direction parameter. *If the transducer cable is wired as specified in this manual* and this bit is reset to zero, the position value will increase with clockwise rotation (looking at the shaft). If this bit is set to one, the position count to increase with counter-clockwise rotation.

TR: Tachometer Response: When this bit is reset to zero, the Tach Response parameter is set to 120 mSec. When this bit is set to one, the Tach Response parameter is set to 32 mSec.

RType: Resolver Type: When this bit is reset to zero, the Resolver Type parameter is set to AMCI. When this bit is set to one, the Resolver Type parameter is set to Autotech. This bit is only acted upon when the Channel Number 'ChNum' bit equals zero.

DType: Data Type: When this bit is reset to zero, the position and tach values are sent to the processor in binary format. When this bit is set to one, the position and tach values are sent to the processor in BCD format. This bit is only acted upon when the Channel Number 'ChNum' bit equals zero.



BLOCK TRANSFER DATA FORMAT

BTW Data Format (continued)

Bit Values (continued)

ClrErr: Clear Errors: When this bit is set, the module will clear any programming errors and attempt to clear a nvRAM error if one exists. Setting this bit will not clear a reference error. Reference errors can only be cleared by properly attaching a working transducer.

Prgm: Program: Programming changes are only made when this bit equals one. If this bit equals zero, the programming bits are ignored.

Sample ladder logic is given at the end of the chapter.

Block Transfer Read Data Format

The format of the block transfer read data is given in figure 4.2. The position and tachometer data is transmitted in binary or BCD format and is stored in the lower bits of the words. The two most significant bits of the position word are used to transmit error information to the processor. In order to maintain backwards compatibility, bit 15 of the tachometer data words is a redundant fault bit.

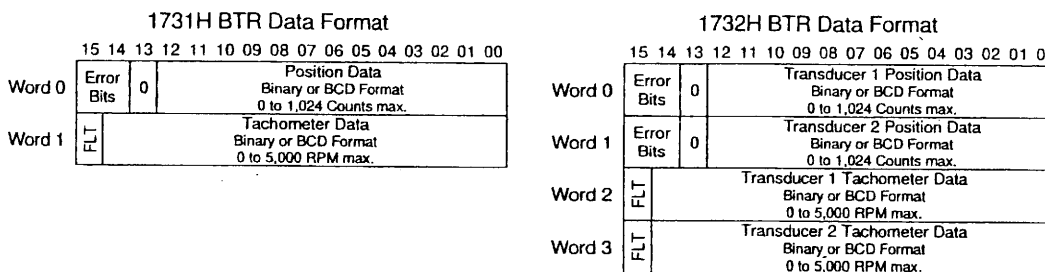

Figure 4.2 BTR Data Format

Bit Values

Position Data: The position data is stored in the least significant bits of the word. The number of bits used is a maximum of nine when transmitted in binary or a maximum of thirteen when transmitted in BCD. The position data equals zero when there is an error.

Tachometer Data: The tachometer data is stored in the least significant bits of the word. The number of bits used is a maximum of thirteen when transmitted in binary or a maximum of fifteen when transmitted in BCD. The position data equals zero when there is an error.

BLOCK TRANSFER DATA FORMAT

Block Transfer Read Data Format (continued)

Bit Values (continued)

Error Bits: These two bits in the position data report to the processor any programming or setup errors with the module. When either one of these bits is set, the position data equals zero. Table 4.2 lists the combinations of these bits and their meaning.

Bit 15	Bit 14	Error
0	0	No Error: Position data transmitted in the word.
0	1	Programming Error: One of the reserved bits in the programming word was set. These bits must equal zero. To clear a programming error, you must reprogram the module with the Clear Errors bit set. A 1732H sets these bits on the channel that has the error.
1	0	Transducer or nvRAM Error: There is a transducer fault or the data in the nvRAM is corrupted. You can check the Indicator LEDs' on the front panel to determine the exact error. A transducer fault will clear itself once a working transducer is properly attached to the module. In order to clear a nvRAM error, you must reprogram the module with the Clear Errors bit set. If a nvRAM error cannot be cleared, or if the error occurs on every power up, the module must be returned for repair. Refer to the inside front cover for information on contacting AMCI. A 1732H sets these bits on the channel that has the error.
1	1	Reference Error: The reference adjustment constants in the nvRAM are corrupted. The only way to clear this error is to properly attach a working transducer to the module. If the error does not clear, contact AMCI for assistance. Refer to the inside front cover for information on contacting AMCI. When a reference error occurs in a 1732H, these bits are set in both position values.

Table 4.2 Error Bit Values

FLT: Fault Bit: This bit is included in the tachometer data in order to maintain backwards compatibility. When this bit is set, there is a Transducer or nvRAM Error, and the tachometer data equals zero. See the error description in Table 4.2 above.



BLOCK TRANSFER DATA FORMAT

Sample Program

The following sample ladder logic shows how to program and read a module using block transfers. Data table values are also included.

```
Rockwell Software Company
6200 Series Software
PLC-5 Programming Terminal Software
Release 5.21
Program Listing Report

1731H Block Transfer Programming Example
Thu Mar 19, 1998 - 12:38:18 pm

File: C:\IPDS\ARCH\PLC5\1730HBLK

REPORT OPTIONS
Page Width: 80
Page Length: 66
Graphics Capabilities: NO
Right Power Rail: YES
Address Display: SYMBOL
Address Comments: YES
Rung Comments: YES
Output Cross Reference: NO
Ladder Cross Reference: NONE
Starting Rung: 2:0
Ending Rung: 999:32767
Formatting Commands: ACTIVE
```

BLOCK TRANSFER DATA FORMAT



Sample Program (continued)

1731H Block Transfer Programming Example Thu Mar 19, 1998 Page 1
 Program Listing Report PLC-5/11 File 1730HBLK Rung 2:0

Rung 2:0
 Block Transfer Read the data from the 1731H module located in rack 0 slot 0 of the PLC rack. If a 1732H module is being used, the Block Transfer Read length should be set to 4 words.

BTR enable bit BT9:0]/[EN	BTR for 1731H module +BTR-----+ BLOCK TRANSFER READ +- (EN) -+ Rack 00 Group 0+- (DN) Module 0 Control block BT9:0+- (ER) Data file N7:10 Length 2 Continuous N +-----+
---	---

Rung 2:1
 When the BTR Done Bit is set, and if both of the 1731H error bits are not set, move through a mask the Block Transfer Read position data to N7:20, and move the velocity data to N7:21. The ladder logic program should act on the buffered data because it will not change during the entire program scan. Please note, if either of the error bits are set, the buffered data will not change until the errors have been cleared.

1731H BTR Done bit BT9:0] [-----] / [-----] / [DN 15 14	1731H data upper error bit N7:10 1731H data lower error bit N7:10 buffered 1731H position data +MVM-----+ MOVE WITH MASK +-+ Source N7:10 188 Mask 1FFF Destination N7:20 188 +-----+ buffered 1731H velocity data +MOV-----+ +MOVE Source N7:11 0 Destination N7:21 0 +-----+
---	---



BLOCK TRANSFER DATA FORMAT

Sample Program (continued)

1731H Block Transfer Programming Example
Program Listing Report

Thu Mar 19, 1998 Page 2
File 1730HBLK Rung 2:2

Rung 2:2

Manually set bit N7:0/0 to program the 1731H module. The one word of data contained in register N7:30 programs the scale factor to its maximum value of 1024 by setting bits 4, 5, and 6. Bit 15, the Program Bit, is also set in word N7:30.

manually set to program 1731H	manually set to zero 1731H	programs 1731H
N7:0	N7:0	
0	1	
+BTW-----+ +BLOCK TRANSFER WRITE +-(EN)-+		
		Rack 00
		Group 0--(DN)
		Module 0
		Control block BT9:1--(ER)
		Data file N7:30
		Length 1
		Continuous N

Rung 2:3

Manually set bit N7:0/1 to cause the 1731H modules position to go to zero. The data contained in register N7:31 only has bit 0 set because you cannot zero the position and program the module at the same time.

manually set to program 1731H	manually set to zero 1731H	zeros 1731H
N7:0	N7:0	
0	1	
+BTW-----+ +BLOCK TRANSFER WRITE +-(EN)-+		
		Rack 00
		Group 0--(DN)
		Module 0
		Control block BT9:2--(ER)
		Data file N7:31
		Length 1
		Continuous N