

# SERIES 1960/V

## INTELLIGENT RESOLVER INTERFACE MODULE

### USER'S MANUAL

Catalog Number 1960-195M

This manual is written to explain the operation of the following AMCI Modules for the GE-Fanuc Series 90™-70 and standard VMEbus systems:

1961	1961V
1962	1962V
1961-06	1961V-06

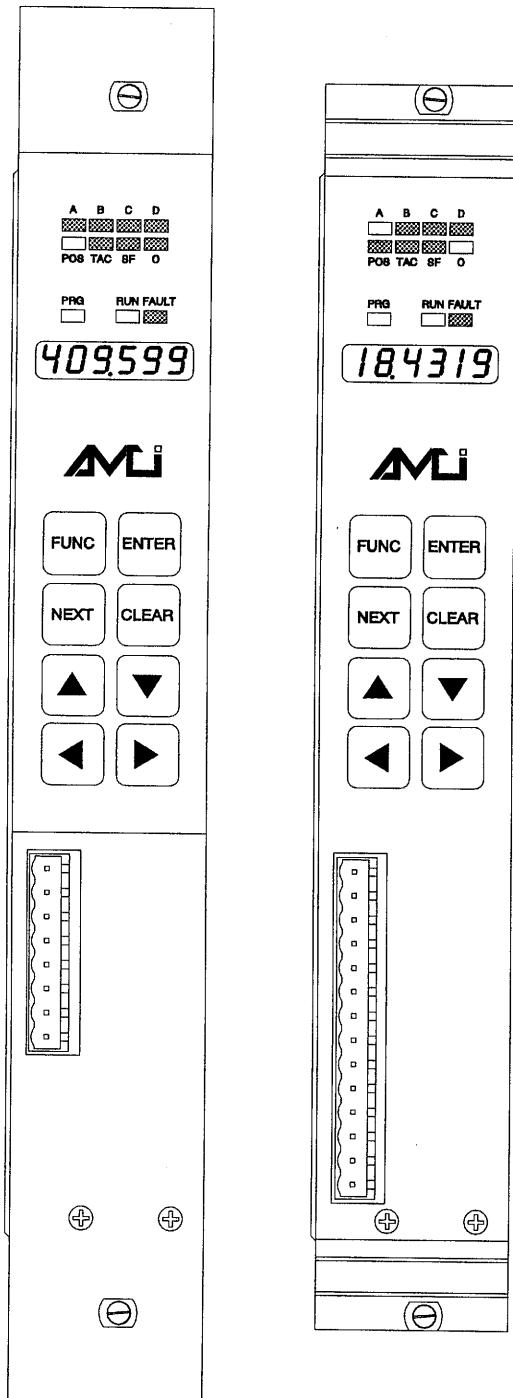

# General Information

---

## *Important User Information*

The products and application data described in this manual are useful in a wide variety of different applications. Therefore, the user and others responsible for applying these products described herein are responsible for determining the acceptability for each application. While efforts have been made to provide accurate information within this manual, AMCI assumes no responsibility for the application or the completeness of the information contained herein.

UNDER NO CIRCUMSTANCES WILL ADVANCED MICRO CONTROLS, INC. BE RESPONSIBLE OR LIABLE FOR ANY DAMAGES OR LOSSES, INCLUDING INDIRECT OR CONSEQUENTIAL DAMAGES OR LOSSES, ARISING FROM THE USE OF ANY INFORMATION CONTAINED WITHIN THIS MANUAL, OR THE USE OF ANY PRODUCTS OR SERVICES REFERENCED HEREIN.

Throughout this manual the following two notices are used to highlight important points.



**WARNINGS** tell you when people may be hurt or equipment may be damaged if the procedure is not followed properly.



**CAUTIONS** tell you when equipment may be damaged if the procedure is not followed properly.

No patent liability is assumed by AMCI, with respect to use of information, circuits, equipment, or software described in this manual.

The information contained within this manual is subject to change without notice.

## *Standard Warranty*

ADVANCED MICRO CONTROLS, INC. warrants that all equipment manufactured by it will be free from defects, under normal use, in materials and workmanship for a period of [1] year. Within this warranty period, AMCI shall, at its option, repair or replace, free of charge, any equipment covered by this warranty which is returned, shipping charges prepaid, within one year from date of invoice, and which upon examination proves to be defective in material or workmanship and not caused by accident, misuse, neglect, alteration, improper installation or improper testing.

The provisions of the "STANDARD WARRANTY" are the sole obligations of AMCI and excludes all other warranties expressed or implied. In no event shall AMCI be liable for incidental or consequential damages or for delay in performance of this warranty.

## *Returns Policy*

All equipment being returned to AMCI for repair or replacement, regardless of warranty status, must have a Return Merchandise Authorization number issued by AMCI. Call (203) 585-1254 with the model number and serial number (if applicable) along with a description of the problem. A "RMA" number will be issued. Equipment must be shipped to AMCI with transportation charges prepaid. Title and risk of loss or damage remains with the customer until shipment is received by AMCI.

## *24 Hour Technical Support Number*

24 Hour technical support is available on this product.

For technical support, call (203) 583-7271.

## General Information

Important User Information .....	Inside Front Cover
Standard Warranty .....	Inside Front Cover
Returns Policy .....	Inside Front Cover
24 Hour Technical Support Number .....	Inside Front Cover

## About This Manual

Introduction .....	I
Revision Record .....	I

## Chapter 1: Introduction to the 1960 Resolver Interface Module

The 1960 Resolver Interface Modules .....	1-1
Series 1900/1900V Family Members .....	1-1
Brushless Resolver Description .....	1-2
Resolver Based Position Transducers .....	1-3
Compatible Position Transducers .....	1-3
1960 Functions and Parameters .....	1-4

## Chapter 2: 1960 Module Description

Front Panel Description .....	2-1
Function and Parameter Displays .....	2-2
Position Data Display .....	2-2
Tachometer Data Display .....	2-2
Transducer Type Parameter .....	2-2
Full Scale Number of Turns Parameter .....	2-3
Full Scale Count Parameter .....	2-3
Counts Per Turn Display .....	2-3
Circular Offset Parameter .....	2-4
Linear Offset Parameter .....	2-4
Decimal Point Parameter .....	2-4
Status Indicators .....	2-5
Error Class 1: Transducer Fault .....	2-5
Error Class 2: E <sup>2</sup> PROM Fault .....	2-5
Program Switch .....	2-6
Keyboard Description .....	2-7
Transducer Input Connector .....	2-8
Fuse Replacement .....	2-8
Series 1900 Specifications .....	2-9
Series 1900V Specifications .....	2-10

## Chapter 3: Installation

Power Requirements .....	3-1
AM Code Configuration .....	3-1
Memory Address Allocation .....	3-1
Installing the Module .....	3-3
Transducer Mounting .....	3-3
Transducer Cable Installation .....	3-4

# Series 1960/V Table of Contents

---

## Chapter 4: Keyboard Programming

Conventions .....	4-1
Transducer Type .....	4-1
Scale Factor Parameters .....	4-2
Circular Offset .....	4-2
Auto Zero .....	4-2
Linear Offset .....	4-3
Decimal Point .....	4-3

## Chapter 5: Series 1960 Data Transfer and Format

VME READ BYTE Function .....	5-1
Parts of the VME_RD_BYTE Function .....	5-1
Contact Input .....	5-1
Coil Output .....	5-1
AM (Address Modifier) Code .....	5-2
LENgth Parameter .....	5-2
Memory Address .....	5-3
Q: (Transfer Destination Address) .....	5-3
Data Byte Significance .....	5-3
Data Format .....	5-4

## Chapter 6: Series 1960V Data Transfer and Format

Standard VME Systems .....	6-1
Data Byte Significance .....	6-1
Addressing Capabilities .....	6-1
D08(E0) Data Transfer .....	6-1
Dual Port RAM Bank Switching .....	6-2
Factory AM Code Configuration .....	6-2
Changing the AM Code .....	6-2
Setting Standard Memory Addresses (A16 - A23) .....	6-5
Data Format .....	6-6

## Prints

B1173	Series 1900 Outline Drawing .....	P-1
B1197	Series 1900V Outline Drawing .....	P-2
B1016 Rev. A	HTT-20-(x) Outline Drawing .....	P-3
B1040 Rev. A	CTT-(x) Transducer Cable Drawing .....	P-4
B1091 Rev. B	C2TT-(x) Transducer Cable Drawing .....	P-5

*Chapter 1: Introduction to the 1960 Resolver Interface Module*

Figure 1.1 Resolver Cut away View .....	1-2
Figure 1.2 Resolver Schematic .....	1-2

*Chapter 2: 1960 Module Description*

Figure 2.1 1960 and 1960V Front Panels .....	2-1
Figure 2.2 Position Display .....	2-2
Figure 2.3 Tach Display .....	2-2
Figure 2.4 Transducer Type .....	2-2
Figure 2.5 Full Scale Number of Turns .....	2-3
Figure 2.6 Full Scale Count .....	2-3
Figure 2.7 Counts per Turn .....	2-3
Figure 2.8 Circular Offset .....	2-4
Figure 2.9 Linear Offset .....	2-4
Figure 2.10 Decimal Point .....	2-4
Figure 2.11 Transducer Fault .....	2-5
Figure 2.12 E <sup>2</sup> PROM Fault .....	2-5
Figure 2.13 Program Switch .....	2-6
Figure 2.14 Keyboard Description .....	2-7
Figure 2.15 Transducer Input Connector Part Numbers .....	2-8
Figure 2.16 Power Fuse .....	2-8

*Chapter 3: Installation*

Figure 3.1 Address Modifier Codes .....	3-1
Figure 3.2 DIP Switch Location .....	3-1
Figure 3.3 DIP Switch Settings .....	3-2
Figure 3.4 Recommended Shaft Loading Maximums .....	3-3
Figure 3.5 HTT-20-(x) Outline Drawing .....	3-4
Figure 3.6 Transducer Cable Part Numbers .....	3-4
Figure 3.7 CTT-(x) Wiring Diagram .....	3-5
Figure 3.8 C2TT-(x) Wiring Diagram .....	3-6

*Chapter 5: Series 1960 Data Transfer and Format*

Figure 5.1 GE Fanuc's VME_READ Function .....	5-1
Figure 5.2 Address Modifier (AM) Code .....	5-2
Figure 5.3 Length Parameter Values .....	5-2
Figure 5.4 Address Allocations .....	5-3
Figure 5.5 Series 1960 Data Format .....	5-4

*Chapter 6: Series 1900V Data Transfer and Format*

Figure 6.1 Last Used Memory Addresses .....	6-1
Figure 6.2 1960V Side Panel Removal .....	6-2
Figure 6.3 AM Code Jumpers .....	6-3
Figure 6.4 BJP6 Pin-out .....	6-3
Figure 6.5 Jumper Settings - VME Specified AM Codes .....	6-4
Figure 6.6 Jumper Settings - User Defined AM Codes .....	6-5
Figure 6.7 Jumper Settings - Standard Address .....	6-5
Figure 6.8 Series 1960V Data Format .....	6-6

## Series 1900/V List of Figures

---

*Notes*

### *Introduction*

This manual explains the operation, installation, programming, and servicing of two families of Resolver Interface Modules. The first is the Series 1960 family of Resolver Interface Modules for the GE Fanuc Series 90™-70 programmable controller system. GE Fanuc's Series 90™-70 is a VME based system that defines several User Definable options in the VME protocol. The second family of modules is the Series 1960V which are designed for all standard VMEbus systems. It is strongly recommended that you read the following instructions. If there are any unanswered questions after reading this manual, call the factory. An applications engineer will be available to assist you.

Because GE Fanuc has defined several options under the VME protocol, the Series 1960 Modules and the Series 1960V Modules are very similar, but not identical. The major differences are front panel layout and, more importantly, format of the data sent to the programmable controller or VME Master.

Most of the information in this manual applies to both families of modules. The major exceptions are Chapter 5, that applies only to the Series 1960 Modules and Chapter 6, that applies only to the Series 1960V modules. Throughout this manual, the following conventions are used to tell you when information applies to the Series 1960 Modules, the Series 1960V Modules, or both families.

- Sentences that contain the phrase "Series 1960 Modules" such as "Series 1960 Modules for the GE Fanuc Series 90™-70 system use the Intel Convention of storing the least significant byte of data at the even byte locations in memory." signifies that the information applies **ONLY** to the Series 1960 family of modules.
- Sentences that contain the phrase "Series 1960V Modules" such as "Series 1960V Modules use the Motorola Convention of storing the least significant byte of data at the odd byte locations in memory." signifies that the information applies **ONLY** to the Series 1960V family of modules.
- Sentences that contain the phrase "1960 Modules" such as "The following is a description of the features found on the 1960 Modules." signifies that the information applies to **BOTH** the Series 1960 and Series 1960V Modules.

"Series 90" is a trademark of GE Fanuc Automation North America, Inc.

Manuals at AMCI are constantly evolving entities. Your questions and comments on this manual and the information it contains are both welcomed and necessary if this manual is to be improved. Please direct all comments to: Technical Documentation, AMCI, Plymouth Industrial Park, Terryville CT 06786, or fax us at (203) 584-1973.

### *Revision Record*

This manual (1960-195M) supercedes manual 1960-A93M. This revision updates print B1091 to Rev C. (Wiring error for the second transducer.) and clarifies how to set the Addressing Dip Switches. It was first released 1/5/95.

## About This Manual

---

*Notes*



## *The 1960 Resolver Interface Modules*

Today's manufacturing processes are becoming more and more complex. Achieving the goals of lower cost production, higher output, less wasted material, and fewer rejects is important if a company is to compete in today's global economy. To achieve these goals, programmable controller systems are being used in more and more applications because of the precise control and flexibility that such a system provides.

One device that accurately and dependably measures rotary position is the brushless resolver. With the introduction of the Series 1960 Modules for the GE Fanuc Series 90™-70 programmable controllers and the Series 1960V for standard VMEbus controllers, interfacing absolute multi-turn brushless resolver transducers to your system has been greatly simplified.

Built around a 16 bit microcontroller and a patented resolver to digital conversion technology, (US patent 4,989,001), the 1960 Modules are direct interfaces between brushless resolvers and your VMEbus programmable controller system. The many features of the 1960 Modules make them the most advanced products on the market today.

- Interfaces one or two absolute multi-turn brushless resolver based transducers to your programmable controller.
- Efficiently communicate absolute position and velocity data to the processor.
- Position resolution fully programmable down to 1024 Counts per Turn. Optionally, the 1961-06 and 1961V-06 Modules offer position resolution to 4096 Counts per turn. Other features include programmable Circular and Linear Position Offsets.
- Self-contained design eliminates the need for an external power supply.
- Extensive diagnostics continuously monitor the transducer and module for fault conditions.
- Sealed display and keyboard for setup programming or position and velocity data monitoring.

## *Series 1900/1900V Family Members*

1931/1931V	10 bit, one channel module	Maximum:	1024 total counts
1932/1932V	10 bit, two channel module	Maximum:	1024 total counts
1933/1933V	10 bit, three channel module	Maximum:	1024 total counts
1934/1934V	10 bit, four channel module	Maximum:	1024 total counts
1941/1941V	13 bit, one channel module	Maximum:	8192 total counts
1942/1942V	13 bit, two channel, module	Maximum:	8192 total counts
1943/1943V	13 bit, three channel module	Maximum:	8192 total counts
1944/1944V	13 bit, four channel module	Maximum:	8192 total counts
1961/1961V	18 bit, one channel module	Maximums:	100/180 turns 1024 counts per turn 184,320 total counts
1962/1962V	18 bit, two channel module	Maximums:	Same as 1961/1961V
1961/1961V-06	20 bit, one channel module	Maximums:	100/180 4096 Counts per turn 737280 total counts

This manual deals with the programming and operation of the 1960 modules. For instructions on the other modules, refer to the Series 1900/V User's Manual.

# CHP 1: Introduction to the 1960 Resolver Interface Modules

## Brushless Resolver Description

The brushless resolver is unsurpassed by any other type of rotary position transducer in its ability to withstand the harsh industrial environment. Originally developed for military applications, the resolver has benefited from more than 40 years of continuous use and development.

The resolver is essentially a variable rotary transformer, with one primary winding, the Reference Winding and two secondary windings, the SIN and COS Windings. (See Fig 1.1). The Reference Winding is located in the rotor of the resolver, the SIN and COS Windings in the stator. The SIN and COS Windings are mechanically displaced 90 degrees from each other.

In general, the Reference Winding is excited by an AC voltage called the Reference Voltage ( $V_R$ ). (See Fig 1.2). In a brushless resolver, the Reference Voltage is supplied to the rotor by using a second rotary transformer on the input. The induced voltages in the SIN and COS Windings are equal to the value of the Reference Voltage multiplied by the SIN or COS of the angle of the input shaft from a fixed zero point.

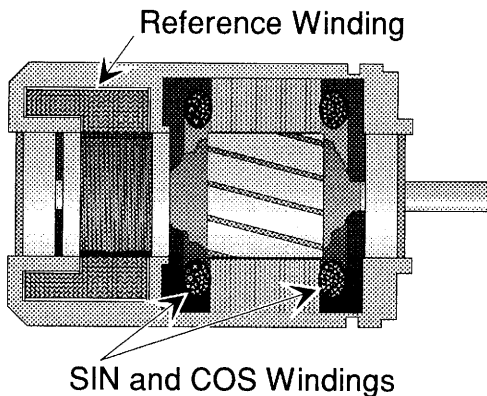

Fig 1.1 Resolver Cut away View

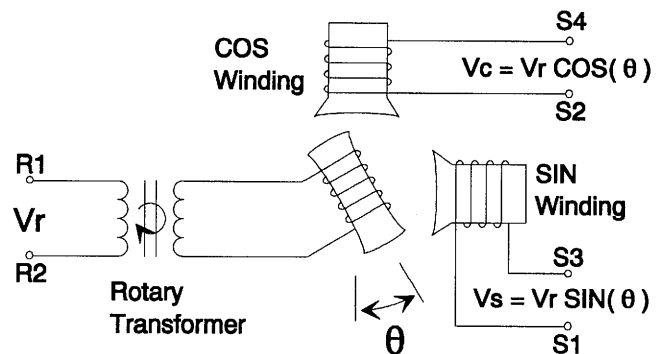

Fig 1.2 Resolver Schematic

The ratio of the SIN voltage to the COS voltage is equal to  $TAN \theta$ , where  $\theta$  is the angle of the input shaft from a fixed zero point. Thus, the resolver can provide a set of voltages whose ratio represents the absolute position of the input shaft. Because the ratio of the SIN and COS voltages is considered, any change in the resolvers' characteristics, such as those caused by aging or a change in temperature, are ignored.

### *Resolver Based Position Transducers*

Mechanically connected to the shaft of the controlled machine, the transducer is subjected to severe environmental conditions such as continuous mechanical shock and vibration, extreme temperature and humidity variations, and exposure to contaminants such as oil mists, coolants, and solvents. AMCI manufactures four rugged, brushless resolver transducers for use with the 1960 Resolver Interface Modules to meet the challenges of this harsh environment. Every transducer manufactured by AMCI have the following features in common.

- Sealed Shaft Bearing.
- MIL Spec Connector for the transducer cable. Every connector bonded to prevent the resolver wires from breaking off due to any vibration that the transducer is subjected to.
- Entire transducer is sealed against liquid and airborne contaminants. (NEMA 13)
- Flexible Coupler between the transducer shaft and resolver protects the resolver from radial and axial shaft loading and high shaft acceleration that can occur when a motor is started.
- Simple ten wire cabling to the modules' transducer input connector.

### *Compatible Position Transducers*

The following resolver based transducers manufactured by AMCI can be used with any 1960 module.

- HTT-20-100 100 Turn absolute position transducer  
1024/4096 counts per turn
- HTT-20-180 180 Turn absolute position transducer  
1024/4096 counts per turn
- HTT-20-1000 1000 Turn absolute position transducer  
102.4/409.6 counts per turn
- HTT-20-1800 1800 Turn absolute position transducer  
102.4/409.6 counts per turn

# CHP 1: Introduction to the 1960 Resolver Interface Modules

---

## *1960 Functions and Parameters*

The 1960's perform two operations. These two operations are called Functions. These Functions are:

**Position Function** - Gives you information on the position of the transducers' shaft relative to a programmable zero point.

**Tachometer Function** - Gives you information on the angular velocity of the transducers' shaft in RPM.

One or more inputs define each Function. One input is the AMCI resolver based transducer. The other inputs are programmable from the keyboard. These inputs are called Parameters.

**Transducer Type** - Specifies the type of transducer attached to the module.

**Full Scale Number of Turns** - Sets the number of turns the transducer completes before rolling over to the zero count.

**Full Scale Counts** - Sets the number of counts over the specified number of turns.

**Circular Offset** - Changes the value of the Position Function without mechanically rotating the transducers shaft.

**Linear Offset** - Adds a fixed number to the value of the Position Function.

**Decimal Point** - Sets the decimal point position for the Position and Offset displays.

*Front Panel Description*

The following is a description of the features found on the 1960 Modules. Separate sections of this chapter describe the parts in detail. Unless otherwise noted, all information presented in this chapter is applicable to all 1960 Modules.

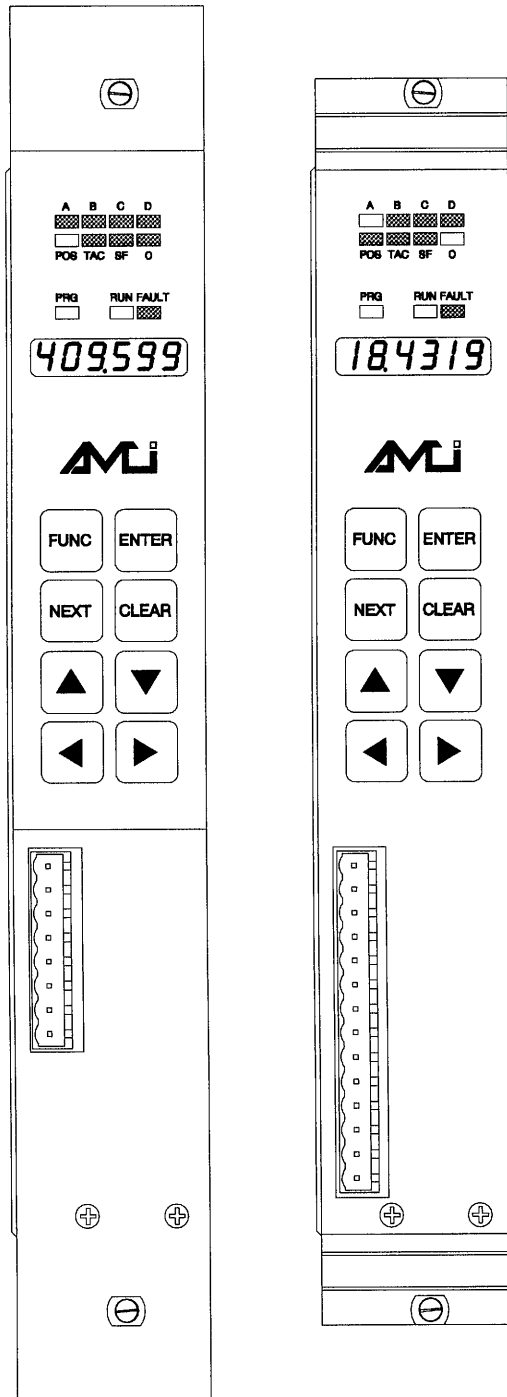

Fig 2.1 1960 and 1960V Front Panels

**Function Display** - Used to show the Functions and Parameters of the 1960 Module. The eight LED indicators designate what is showing on the alpha-numeric display. When in Program Mode, a blinking digit on the display shows the position of the *Cursor*.

**Status Indicators** - Indicates the operating condition of the module.

**PRG** - Yellow light is on when the module is in Program Mode.

**RUN** - Green light is blinking when the module is operating.

**FAULT** - Red light is on when there is a fault condition. The nature of the fault is shown on the alpha-numeric display.

**Program Switch** - Located on the top panel, hidden from view. Used to enable or disable Program Mode. When enabled, the module is programmable from the keyboard.

**Keyboard** - Used to examine or change the Functions and Parameters of the Module.

**Transducer Input Connector** - Connector for one or two AMCI absolute multi-turn brushless resolver based transducers.

### Function and Parameter Displays

The following displays are available on the 1960 Modules. A brief description of each Function or Parameter is given to the right of the display. Unless noted, each of the displays is available on all 1960 Modules. Please note that a shaded LED indicator is not lit on the display.

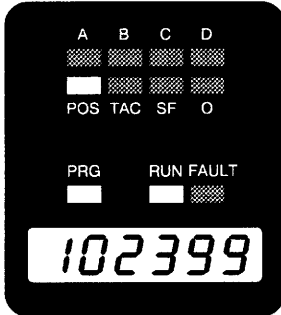

Fig 2.2 Position Display

**Position Data Display** - This display shows the current position of the transducer's shaft. Its value varies from (Linear Offset) to (Linear Offset + (Scale Factor - 1)) On two channel modules, the Position Data Display of the additional transducer is sequentially available by pressing the [NEXT] Key. When displaying the second transducer, the 'D' LED is also on. The Position data is available to the processor.

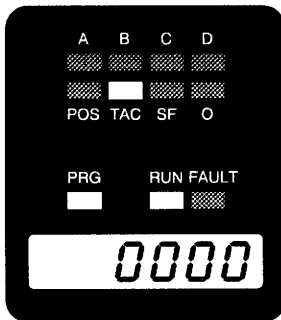

Fig 2.3 Tach Display

**Tachometer Data Display** - This display shows the speed of rotation of the transducer's shaft in RPM. Maximum speed that can be displayed is 2000 RPM. The time between updates, which is the time it takes to determine a new speed and show it on the display is set to 32 mSec. On two channel modules, the Tachometer Data Display of the additional transducer is sequentially available by pressing the [NEXT] Key. When displaying the second transducer, the 'D' LED is also on. Tachometer data is available to the processor.

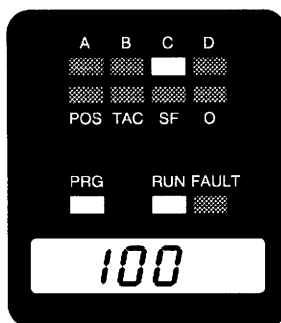

Fig 2.4 Transducer Type

**Transducer Type Parameter** - This parameter configures the module for 100 or 180 turn transducers. If you are using a 1000 turn transducer set this parameter for 100. Likewise, if you are using a 1800 turn transducer, set this parameter for 180. If this parameter is set to the incorrect value, the module will not compute the position value correctly. This parameter also affects the values that can be entered for the Full Scale Number of Turns parameter. On two channel modules, the transducer Type parameter of the additional transducer is sequentially available by pressing the [NEXT] Key. When displaying the second transducer, the 'D' LED is also on.

Function and Parameter Displays (cont'd)

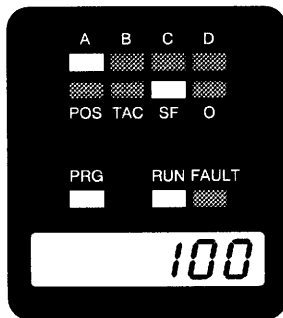

Fig 2.5 Full Scale Number of Turns

**Full Scale Number of Turns Parameter** - This parameter sets the number of turns the transducer must complete before rolling over to the zero count. Linear applications should set this parameter greater than the number of turns in the maximum travel. The allowable values for this parameter depend on the Transducer Type Parameter. If programmed for a 100 turn transducer, the allowable values are 1, 2, 4, 5, 10, 20, 25, 50, and 100. If programmed for a 180 turn transducer, the allowable values are 1, 2, 3, 4, 5, 6, 9, 10, 12, 15, 18, 20, 30, 36, 45, 60, 90, and 180. If you are using a 1000 or 1800 turn transducer, the actual number of turns the transducer must complete is ten times what is shown on the display. On two channel modules, the Full Scale Number of Turns of the additional transducer is sequentially available by pressing the [NEXT] Key. When displaying the second transducer, the 'D' LED is also on.

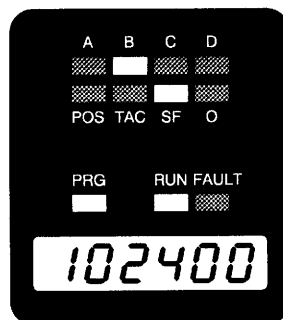

Fig 2.6 Full Scale Count

**Full Scale Count Parameter** - This parameter sets the number of counts over the specified number of turns. This parameter defaults to 1024 counts per turn when the Full Scale Number of Turns parameter is entered. The 1961/V-06 defaults to 4096 counts per turn. On two channel modules, the Full Scale Count of the additional transducer is sequentially available by pressing the [NEXT] Key. When displaying the second transducer, the 'D' LED is also on.

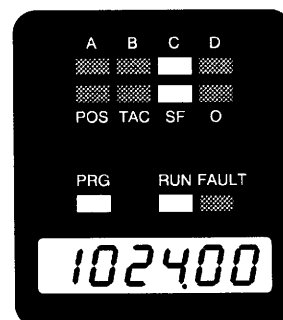

Fig 2.7 Counts per Turn

**Counts Per Turn Display** - For reference only, this display shows the calculated number of counts per turn. If you are using a 1000 or 1800 turn transducer, the actual Counts per Turn is one tenth of what is displayed. To change the number of counts per turn, the Full Scale Number of Turns or Full Scale Count parameters must be changed. On two channel modules, the Counts per Turn display of the additional transducer is sequentially available by pressing the [NEXT] Key. When displaying the second transducer, the 'D' LED is also on.

### Function and Parameter Displays (cont'd)

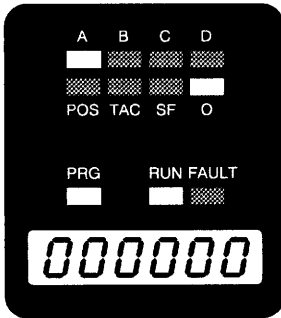

Fig 2.8 Circular Offset

**Circular Offset Parameter** - The Circular Offset parameter allows you to change the value of the Position Function without rotating the transducers' shaft. This offset is most commonly used to force the position to the correct count after the machine has been aligned. The maximum value of the Circular Offset is (Full Scale Count - 1). On two channel modules, the Circular Offset Parameter of the additional transducer is sequentially available by pressing the [NEXT] Key. When displaying the second transducer, the 'D' LED is also on.

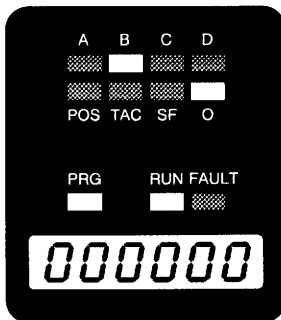

Fig 2.9 Linear Offset

**Linear Offset Parameter** - The Linear Offset Parameter is used to change the RANGE of values of the Position Function. This offset is most commonly used when measuring linear distances. The maximum Position value is 999,999. Therefore, the maximum value for the Linear Offset is (1,000,000 - Full Scale Count). On two channel modules, the Linear Offset Parameter of the additional transducer is sequentially available by pressing the [NEXT] Key. When displaying the second transducer, the 'D' LED is also on.

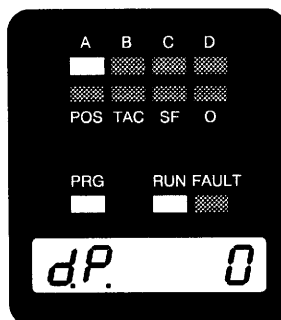

Fig 2.10 Decimal Point

**Decimal Point Parameter** - This parameter forces the module to show a decimal point when displaying the Position and Offset displays. The value of this parameter specifies the number of digits to the right of the decimal point. For example, if this parameter is set to 3 and the position is 25000, it will display as 25.000. This parameter does not affect the position data sent to the PLC. On two channel modules, the Decimal Point Parameter of the additional transducer is sequentially available by pressing the [NEXT] Key. When displaying the second transducer, the 'D' LED is also on.



*Status Indicators*

There are three single LED indicators below the alpha-numeric display that show the operating status of the module.

- PRG: This yellow light is on when the module is in Program Mode. While in Program Mode, all of the parameters can be inspected and altered from the keyboard.
- RUN: A blinking green light indicates that the module is powered and operational.
- FAULT: This red light is on when the module recognizes a fault condition. The type of fault is shown on the alpha-numeric display. The 1960 Modules recognize two types of faults.

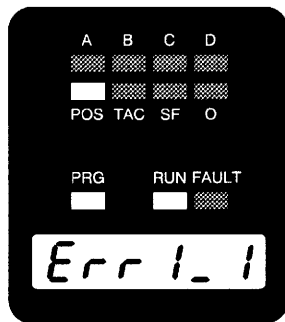

Fig 2.11 Transducer Fault

**Error Class 1: Transducer Fault** - This message is shown only when the module is displaying the Position or Tachometer Functions. The Parameters will be displayed normally. If the message is blinking, press the [CLEAR] key to clear the fault and display the Position or Tachometer data. There are four major causes of this fault:

- Broken Transducer Cable.
- Non-compatible Transducer.
- Improper wiring of the Transducer Cable.
- Faulty Transducer.

If you are using a two channel module, the transducer fault may not be on the channel that is being shown on the modules' display. In this case, the fault light will be on but the module will be displaying Position and Tachometer information. Use the [NEXT] Key to cycle to the next channel. If there is a fault on both channels, the display will show 'Err1 \_2'

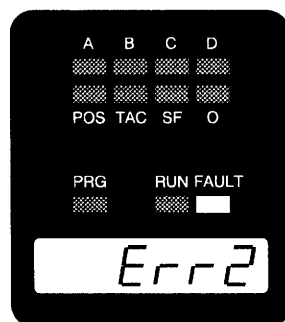

Fig 2.12 E<sup>2</sup>PROM Fault

**Error Class 2: E<sup>2</sup>PROM Fault** - This message is displayed at all times. The module recognizes that the program data (Scale Factor, Offsets, etc.) is incorrect. This error can be cleared by pressing the [CLEAR] Key. If the "Err 2" message remains after pressing the [CLEAR] Key, the E<sup>2</sup>PROM memory is damaged and the module must be returned for repairs. See inside front cover *Returns Policy*: for additional information.

### Program Switch

The Program Switch is used to enable or disable programming of the 1900 Module. The module is programmable (Program Mode, PRG light ON) when the switch is pushed towards the front of the module. When in Program Mode, all parameters can be modified. The module is not programmable (Display Mode, PRG light OFF) when the switch is pushed towards the back of the module. When in Display Mode, all parameter values can be examined but cannot be modified.

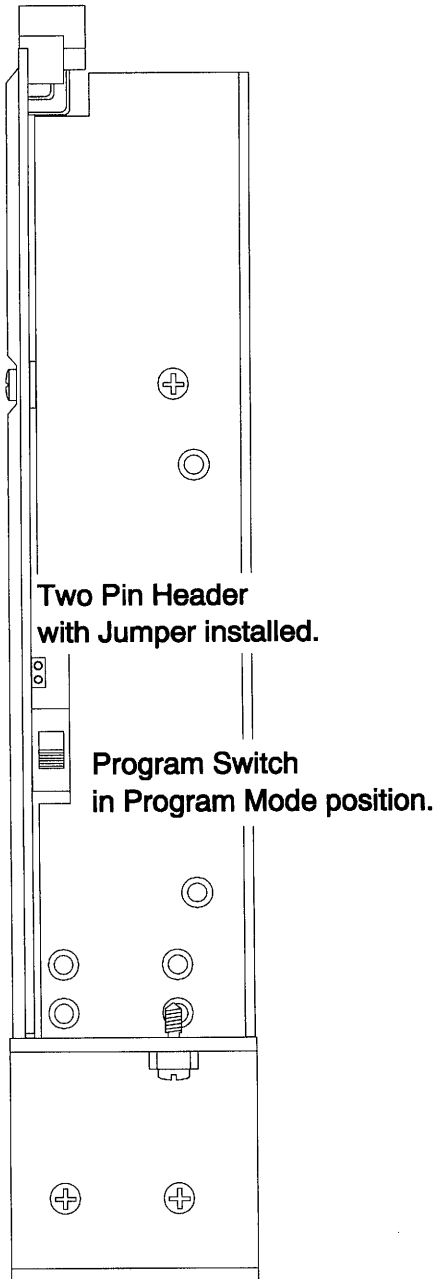

Fig 2.13 Program Switch



Remove system power before removing or installing a module in the I/O Rack. Failure to observe this warning can result in damage to the module's circuitry and/or undesired operation with possible injury to personnel.

The Program Switch can be disabled by removing the jumper on the two pin header next to the switch. Removing this jumper locks the 1960 in Display Mode. It is usually good practice to remove this jumper once the system is operational. This will prevent someone from accidentally changing the 1960's parameters while the system is running. The only times that changes to the modules programming should be allowed are during set-up or trouble shooting procedures.

*Keyboard Description*

The following table describes what the keys do when you are in Display Mode, (PRG light OFF) or Program Mode (PRG light ON). When in Program Mode, a parameter that you show on the display can be changed if one of the digits on the display is blinking. The blinking digit shows the position of the Cursor.



<i>Key</i>	<i>Display Mode</i>	<i>Program Mode</i>
	Use this key to select the function or parameter you wish to show on the display.	Same as Display Mode.
	Not used in Display Mode.	If a parameter is shown with the Cursor, pressing this key will store the displayed value in E2PROM Memory.
	Use this key to recover from fault conditions. The exact nature of the fault is shown on the display. See <i>Status Indicators</i> Pg. 2-5.	Same as Display Mode. If the Position Function is on the display, press this key to use the AUTO ZERO feature
	Used to switch between the transducer inputs on a multi-channel module.	Same as Display Mode.
	Not used in Display Mode.	If the Cursor is shown, use these keys to increment [▲] or decrement [▼] the number under the cursor.
	These Keys can be used to select the Function or Parameter that you wish to show on the display.	If the Cursor is shown, these keys shift the Cursor to the left [◀] or the right [▶] by one digit.

Fig 2.14 Keyboard Description

## CHP 2: 1960 Module Description

---

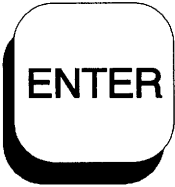
### Transducer Input Connector

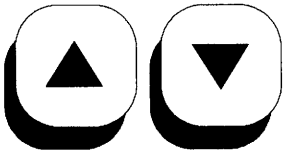
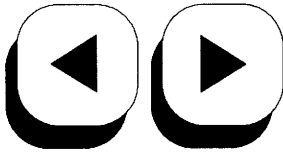
The Transducer Input Connector on the 1961, 1961V, 1961-06, and 1961V-06 modules has eight contacts while the Transducer Input Connector on the 1962 and 1962V modules has fourteen contacts. The following table lists the AMCI and Phoenix Contact part numbers on the mating connectors:

	1 Channel Modules	2 Channel Modules
AMCI Part #	MS-8	MS-14
Phoenix Part #	MSTB1.5/8-ST-5.08	MSTB1.5/14-ST-5.08

Fig 2.15 Transducer Input Connector Part Numbers

The pin-out of the cables are given in Chapter 3, **Installation**.

### Fuse Replacement

If the Power Fuse fails, it can be easily replaced. The factory installed fuse is a 1.5 Amp Fast Blow, Littelfuse Part Number 22501.5. Fuse kits are available from AMCI. The AMCI Part number is SKF-3. Each fuse kit contains five fuses.



To insure continued and adequate protection, any replacement fuse must have a rating of 1.5 Amp Fast Blow. Using a higher ampere rating or slow blow fuses may not protect the module from damage if the fault conditions are again applied to the module.



Remove system power before removing or installing a module in the I/O Rack. Failure to observe this warning can result in damage to the module's circuitry and/or undesired operation with possible injury to personal.

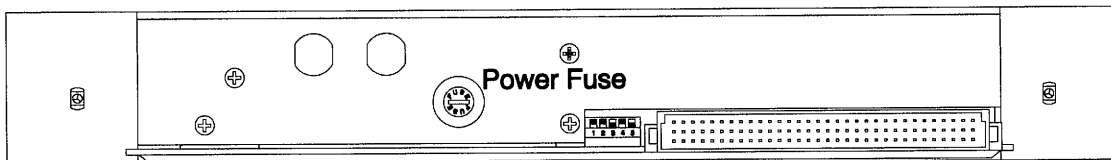

Fig 2.16 Power Fuse

### Series 1900 Specifications

#### Module Interface

Bus slave module. Compatible with GE Fanuc's Industrialized VMEbus (VME-I).

#### Position Transducer

AMCI Brushless Resolver

#### Transducer Input

Transformer Isolated

#### Compatible Transducers

1930/40V: HT-20(/S), H25F/SE, HT-20-(X)

1960V: HTT-20-100/180/1000/1800

#### Maximum Position Resolution

1930V: Programmable to 1 part in 1024

1940V: Programmable to 1 part in 8192

1960V: Programmable to 1 part in 1024 per turn

#### New Position Throughput Time

400  $\mu$ Sec: 1931, 32, 41, 42, 61

800  $\mu$ Sec: 1933, 34, 43, 44, 62

#### Programmable Parameters

Scale Factor

Number of Turns (1961/2 only)

Decimal Point Position (1961/2 only)

Circular Offset

Linear Offset

Tachometer response time (1930/40 only)

Tachometer resolution (1930/40 only)

#### Number of Turns

1930/40: 1, 2, 3, 4, 6, 7, 8, 10, 12, 16, 20, 24, 36, 40, 50, 60, 64, 100, 150, 250.

1960: 100 Turn Transducer:

1, 2, 4, 5, 10, 20, 25, 50, 100 turns.

180 Turn Transducer:

1, 2, 3, 4, 5, 6, 9, 10, 12, 15, 18, 20, 30, 36, 45, 60, 90, 180 turns.

#### Programmable Tach Response Time

32, 60, 120, or 240 mSec: (1930/40)

Set to 32 mSec: (1960)

#### Tachometer Resolution

1 RPM at 32, 60, 120 mSec response times.

Programmable to 1.0 RPM or 0.1 RPM at 240 mSec response time.

#### Tachometer Range

0 to 2000 RPM at 32, 60, or 120 mSec response times

0 to 1000 RPM or 0.0 to 999.9 RPM at 240 mSec response time

#### Position Offset

Circular Offset programmable from 0 the Full Scale Count

Linear Offset programmable from 0 to:  
(9999 - Full Scale Count) 1930/40  
(999999 - Full Scale Count) 1960

#### Data Available to Processor

Transducers' Shaft Position, Shaft Velocity, and Fault Diagnostics data

#### Program Input

Modules' self-contained keyboard and display

#### Program Storage

E<sup>2</sup>PROM Memory

#### DC Supply Current from Backplane

+5 Vdc @ 1.05 A max. (1934/44/62 Modules)

#### Modules' +5 Vdc Supply Fuse

1.5A Fast Blow (Littelfuse 22501.5)

#### Environmental Conditions

Operating Temperature: 0 to 60° C

Relative Humidity: 5 to 95%  
(w/o condensation)

Storage Temperature: -40 to 85° C

## CHP 2: 1960 Module Description

---

### Series 1900V Specifications

#### Module Interface

2 Slot, 6U Bus slave module. Compatible with A16, A24, and D08(EO) protocols.

#### Position Transducer

AMCI Brushless Resolver

#### Transducer Input

Transformer Isolated

#### Compatible Transducers

1930/40V: HT-20(/S), H25F/SE, HT-20-(X)

1960V: HTT-20-100/180/1000/1800

#### Maximum Position Resolution

1930V: Programmable to 1 part in 1024

1940V: Programmable to 1 part in 8192

1960V: Programmable to 1 part in 1024 per turn

#### New Position Throughput Time

400  $\mu$ Sec: 1931V, 32V, 41V, 42V, 61V

800  $\mu$ Sec: 1933V, 34V, 43V, 44V, 62V

#### Programmable Parameters

Scale Factor

Number of Turns (1961/2V only)

Decimal Point Position (1961/2V only)

Circular Offset

Linear Offset

Tachometer response time (1930/40V only)

Tachometer resolution (1930/40V only)

#### Number of Turns

1930/40V: 1, 2, 3, 4, 6, 7, 8, 10, 12, 16, 20, 24, 36, 40, 50, 60, 64, 100, 150, 250.

1960V: 100 Turn Transducer:

1, 2, 4, 5, 10, 20, 25, 50, 100 turns.

180 Turn Transducer:

1, 2, 3, 4, 5, 6, 9, 10, 12, 15, 18, 20, 30, 36, 45, 60, 90, or 180 turns.

#### Programmable Tach Response Time

32, 60, 120, or 240 mSec: (1930/40V)

Set to 32 mSec: (1960V)

#### Tachometer Resolution

1 RPM at 32, 60, or 120 mSec response times.

Programmable to 1.0 RPM or 0.1 RPM at 240 mSec response time.

#### Tachometer Range

0 to 2000 RPM at 32, 60, or 120 mSec response times

0 to 1000 RPM or 0.0 to 999.9 RPM at 240 mSec response time

#### Position Offset

Circular Offset programmable from 0 the Full Scale Count

Linear Offset programmable from 0 to:

(9999 - Full Scale Count) 1930/40V

(999999 - Full Scale Count) 1960V

#### Data Available to Processor

Transducers' Shaft Position, Shaft Velocity, and Fault Diagnostics data

#### Program Input

Modules' self-contained keyboard and display

#### Program Storage

E<sup>2</sup>PROM Memory

#### DC Supply Current from Backplane

+5 Vdc @ 1.05 A max. (1934/44/62 Modules)

#### Modules' +5 Vdc Supply Fuse

1.5A Fast Blow (Littelfuse 22501.5)

#### Environmental Conditions

Operating Temperature: 0 to 60° C

Relative Humidity: 5 to 95%

(w/o condensation)

Storage Temperature: -40 to 85° C

*Power Requirements*

Each 1960 Module draws its power from the backplane's +5 Vdc Supply. The maximum current draw is 1.050 Amps (5.25W). Add this to the power requirements of all other cards in the rack to avoid exceeding backplane or power supply capacity.

*AM Code Configuration*

Every 1960 Module is factory configured to respond to the address modifier (AM) code of 29h. This AM code stands for Short (16 bit address) Non-Privileged VME access and is the default used by GE-Fanuc Series 90™-70 systems. For GE-Fanuc installations, you need only set the slot number (address range) with DIP Switches located next to the backplane connector.

If you use a Series 1960V Module in a VME system, you can configure the module to respond to the following Standard AM Codes:

Address Modifier Code	Transfer Type	# of Address Bits
29h	Short Non-Privileged Access	16
2Dh	Short Supervisory Access	16
39h	Standard Non-Privileged Data Access	24
3Dh	Standard Supervisory Data Access	24

Fig 3.1 Address Modifier Codes

You can also configure a Series 1960V Module for User Defined AM Codes, however your VME Master must be able to generate these AM Codes. If you need to change the AM Code that the module responds to, refer to *Changing the AM Code*, Pgs 6-2 to 6-5.

*Memory Address Allocation*

After configuring the module to respond to the correct AM code, you must assign the memory addresses that the module responds to. When using the AM code of 29h, the 1960 Module can be located anywhere in the A16 Short Address space of the VMEbus at 2k boundaries by setting the DIP Switches located next to the backplane connector. (See Fig 3.2 below.)

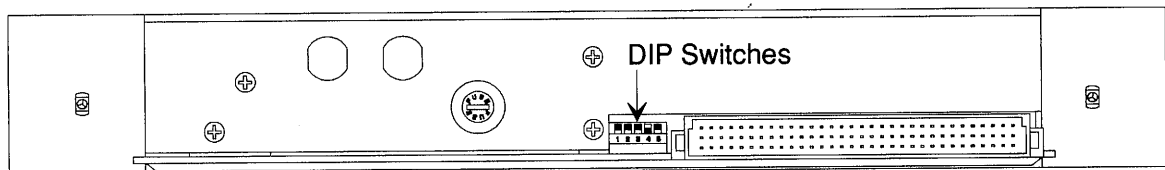

Fig 3.2 DIP Switch Location

DIP Switches 1 through 5 correspond to address lines A15 through A11 on the VMEbus backplane. The starting memory location, in Binary, of the 1960 Module is:

XXXX X000 0000 0000b, where: XXXX X are the values specified by the DIP Switches.

A closed DIP Switch, (towards the PC Board), sets the Address bit to a "0". An open Dip Switch, (towards the metal case), sets the Address bit to a "1".

# CHP 3: Installation

## Memory Address Allocation (cont'd)

GE Fanuc assigns default memory locations for each slot in an I/O rack. In most applications, the 1900 Module should be configured to use the memory locations assigned to the slot that it resides in. GE Fanuc systems also set aside a User Defined Memory Area, addresses 5000h to FFFFh, in each rack. This memory area can be used by a 1960 Module if another module in the rack requires the memory normally assigned to the module.

A closed DIP Switch, (lever towards the PC Board), sets the Address bit to a "0". An open Dip Switch, (lever towards the metal case), sets the Address bit to a "1".

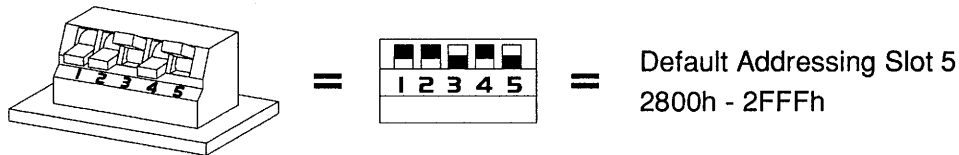

Memory Locations	GE Slot #	DIP Switch	Memory Locations	GE Slot #	DIP Switch
0000h - 07FFh	None		8000h - 87FFh	User Def.	
0800h - 0FFFh	None		8800h - 8FFFh	User Def.	
1000h - 17FFh	2		9000h - 97FFh	Used Def.	
1800h - 1FFFh	3		9800h - 9FFFh	User Def.	
2000h - 27FFh	4		A000h - A7FFh	User Def.	
2800h - 2FFFh	5		A800h - AFFFh	User Def.	
3000h - 37FFh	6		B000h - B7FFh	User Def.	
3800h - 3FFFh	7		B800h - BFFFh	User Def.	
4000h - 47FFh	8		C000h - C7FFh	User Def.	
4800h - 4FFFh	9		C800h - CFFFh	User Def.	
5000h - 57FFh	User Def.		D000h - D7FFh	User Def.	
5800h - 5FFFh	User Def.		D800h - DFFFh	User Def.	
6000h - 67FFh	User Def.		E000h - E7FFh	User Def.	
6800h - 6FFFh	User Def.		E800h - EFFFh	User Def.	
7000h - 77FFh	User Def.		F000h - F7FFh	User Def.	
7800h - 7FFFh	User Def.		F800h - FFFFh	User Def.	

Fig 3.2 DIP Switch Settings



*Installing the Module*



Remove system power before removing or installing a module in the VME rack. Failure to observe this warning can result in damage to the module's circuitry and/or undesired operation with possible injury to personal.

After selecting the proper AM Code and memory addresses, the module is ready to be inserted into the rack. Insert the P.C. Board into the card guides and gently seat the P1 connector into the backplane. Seating the connector does not require a great amount of force. Applying too much pressure on a mis-aligned connector may damage the module or backplane.

After seating the module in the backplane, secure the module the rack with the two mounting screws.



The two mounting screws that secure the module to the rack are also the grounding points for the 1960. These two screws **MUST** be tightly screwed into the rack for proper operation.

*Transducer Mounting*

All AMCI resolver based transducers are designed to operate in the industrial environment and therefore require little attention. However, there are some general guidelines that should be observed to ensure long life.

- Limit transducer shaft loading to the following maximums:

Radial Loads	100 lbs. (445 N)
Axial Loads	50 lbs. (222.5 N)

Fig 3.4 Recommended Shaft Loading Maximums

- Minimize shaft misalignment when direct coupling shafts. Even small misalignments produce large loading effects on front bearings. It is recommended that you use a flexible coupler whenever possible.

The figure on the following page is the dimensional drawing of the HTT-20-(x) transducers for use with the 1960 modules. An Engineering Print is at the back of the manual. The print number is B1016.

# CHP 3: Installation

## Transducer Mounting (cont'd)

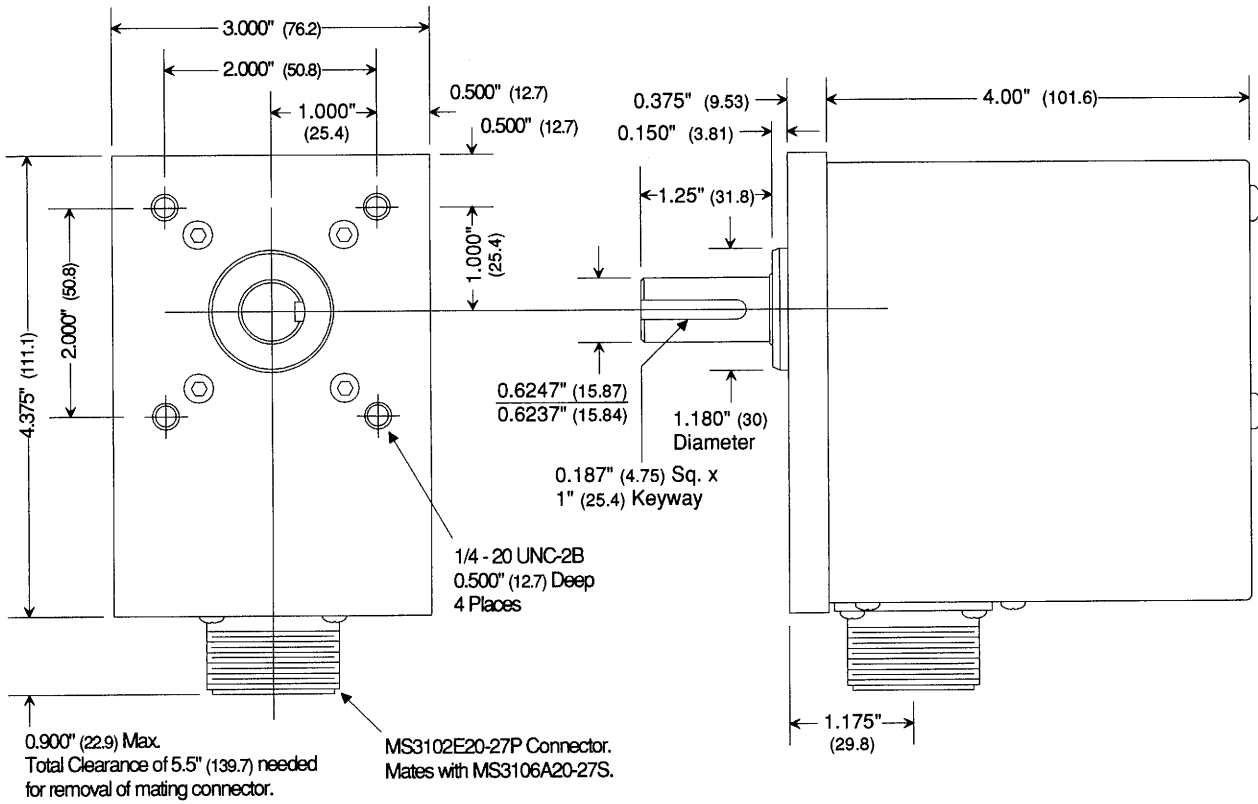

Fig 3.5 HTT-20-(x) Outline Drawing

## Transducer Cable Installation

Use the table below to determine the correct cable and connectors for your application. Cables that have been assembled and tested are available from AMCI under the given part numbers. If you plan to make your own cables, the required cable and connectors can be ordered from AMCI.

Module	AMCI Cable #	Belden #	Module Conn.	Transducer Conn.
1961	CTT - (x)	9731	MS-8	MS-20 (1)
1962	C2TT - (x)	9731	MS-14	MS-20 (2)

Fig 3.6 Transducer Cable Part Numbers

The figures below and on the following page are the wiring diagrams of the transducer cables. Engineering prints of these cables are also given at the back of the manual. The print numbers are:

- **B1040 Rev A:** CTT-(x) Cable Drawing
- **B1091 Rev C:** C2TT-(x) Cable Drawing

**ⓘ CAUTION**

Cable shields must be grounded at the 1900 Module ONLY! The shields must not be connected to the transducer and must be isolated from the raceway that the cable is installed in. This practice will eliminate ground loops that may induce EMI noise into the cable or damage the 1960 module.

**ⓘ CAUTION**

Pin 1 of the Transducer Input Connector is located towards the top of the module, NOT the bottom as this drawing may imply. Reversing the wires on the Module Connector will not harm the module or the transducer, but the transducer will not operate.

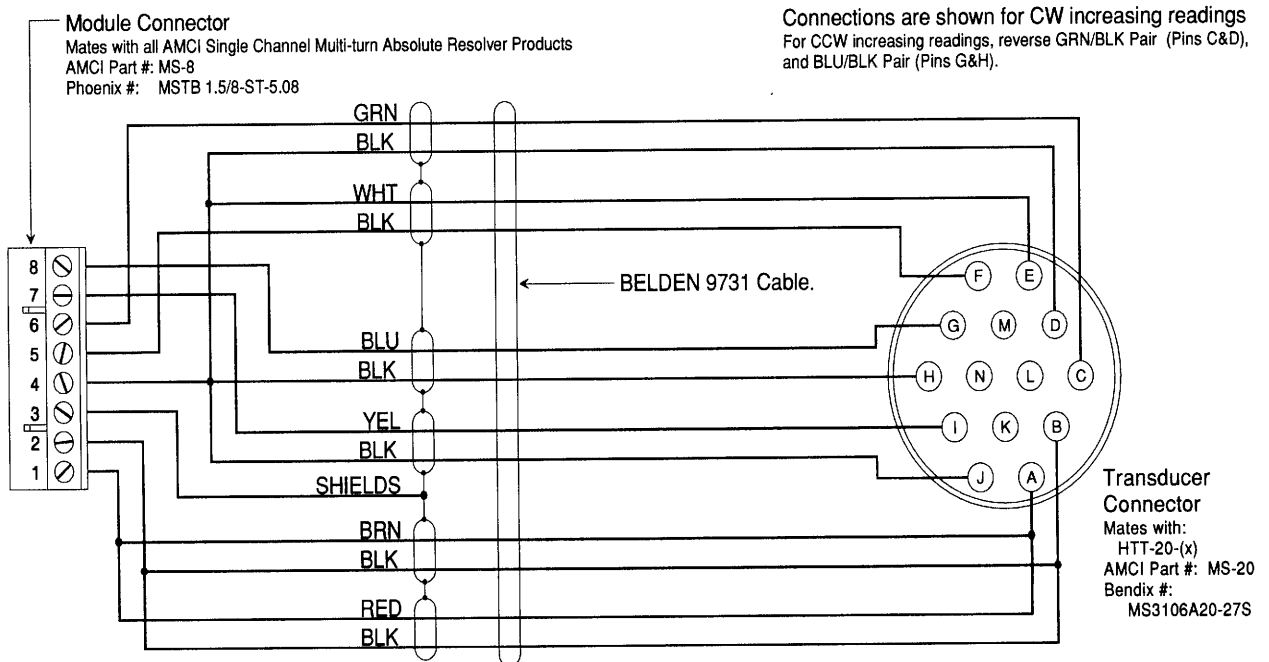

Fig 3.7 CTT-(x) Wiring Diagram

# CHP 3: Installation

## Transducer Cable Installation (cont'd)

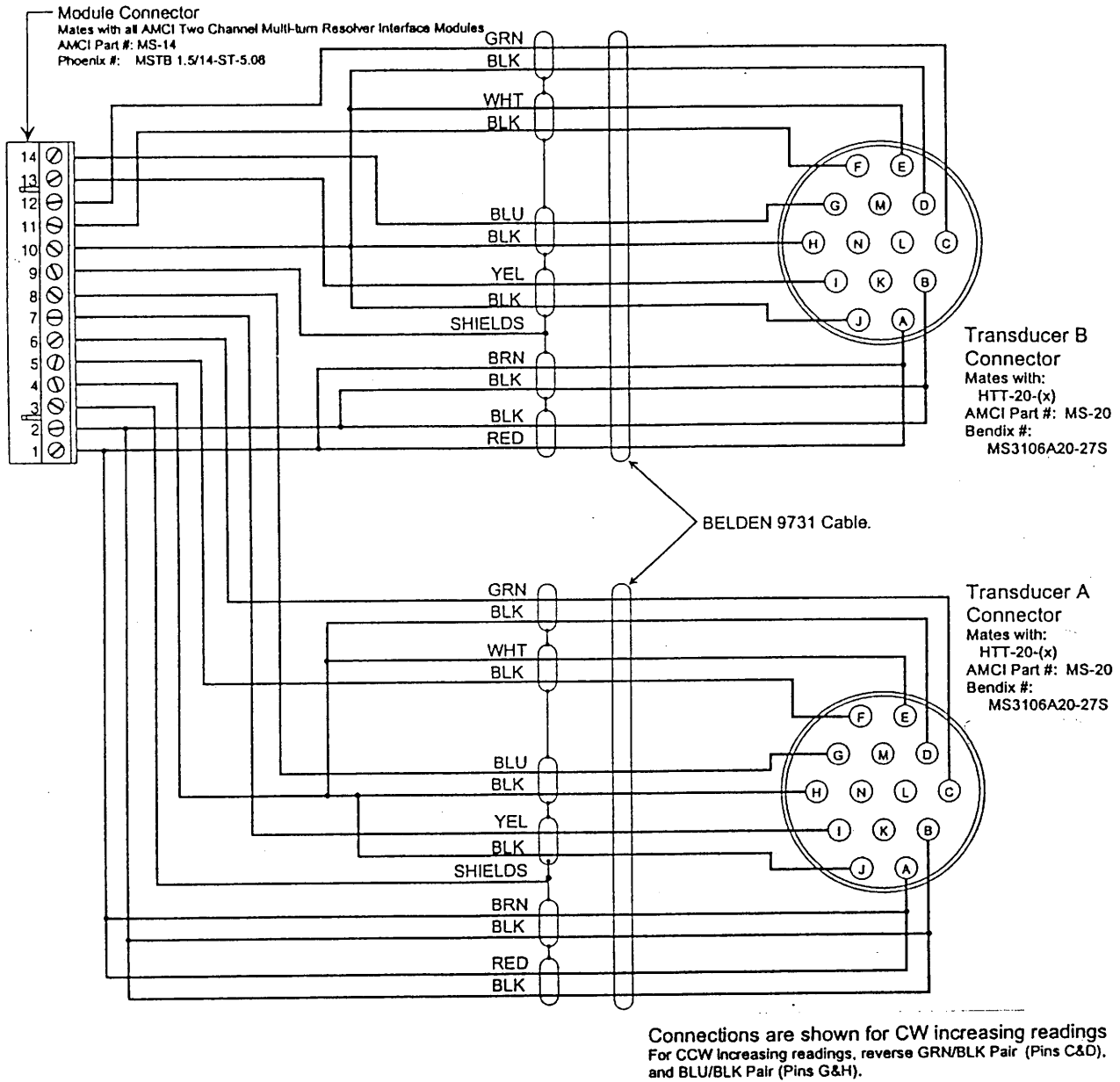

Fig 3.8 C2TT-(x) Wiring Diagram

This chapter offers examples on how to program the 1960 Modules. Unless noted, all programming examples are applicable to all 1960 Modules.

Before any of the 1960's parameters can be programmed, the module must be in Program Mode. (Program Switch set ON. See *Program Switch* Pg. 2-6 for more information.) When the module is in this mode, the yellow PRG light on the front panel is lit.

## Conventions

The following conventions are used when describing the keystrokes needed to program the different parameters.

[KEY]: Used to show the key pressed on the module. The key's name will be inside the brackets.

If an asterisk appears before a key, (Example: \*[FUNCTION]), the key must be pressed until the display matches what is shown in the instructions.

If a "X" and a number follow a key, (Example: [▲]X3), the key must be pressed the shown number of times. (In this example, the [▲] key would be pressed 3 times.)

IND. LEDS: Indicator LEDs that indicate the function or parameter being displayed or programmed.

"Display": Information shown on the 6 digit display. The blinking cursor is shown by a double underline.

The following keystroke examples use the least number of keystrokes. However, any series of keystrokes is valid as long as the data is correct before the [ENTER] key is pressed.

The following examples use the parameters for the first transducer only. The examples are equally valid for the second channel of a 1962 Module. the only change is that the [NEXT] Key must first be pressed to switch to the second channel. The first and second channels are distinguished by the 'D' Indicator Light. This light is on when displaying functions and parameters of the second transducer.

## Transducer Type

You want to use an HTT-20-100 Transducer with the module. The module is presently configured for the HTT-20-180. Note that a 1962 module can connect to each type simultaneously.

PRESS	IND. LEDS	DISPLAY	COMMENTS
*[FUNCTION]	C	" <u>180</u> "	Present Value.
[▲]	C	" <u>100</u> "	100 Turn Transducer Type.
[ENTER]	C	" 100 "	Value stored in E <sup>2</sup> PROM. Blinking Cursor removed.

## CHP 4: Keyboard Programming

### Scale Factor Parameters

Your setup requires a Full Scale Number of Turns of 50 and a Full Scale Count of 50,000. Presently, the defaults for a 100 turn transducer of 100 and 102400 are programmed in.

PRESS	IND. LEDS	DISPLAY	COMMENTS
*[FUNCTION]	SF + A	" <u>1</u> 00"	Present Number of Turns.
[▼], [▶], [▲]X4, [ENTER]	SF + A	" 050"	Desired Number of Turns. Value stored in E <sup>2</sup> PROM. Blinking Cursor removed.
[FUNCTION]	SF + B	" <u>0</u> 51200"	Default Full Scale Count. 50 * 1024 = 51200 If using a 1961-06, default of 50 * 4096 = 204800
[▶]X2, [▼], [▶], [▼]X2, [ENTER]	SF + B	"050000"	Programmed Full Scale Count
[FUNCTION]	SF + C	"1000.00"	Calculated Counts per Turn.

### Circular Offset

You want to program a Circular Offset of 25 counts. The default value of 0000 is presently in memory.

PRESS	IND. LEDS	DISPLAY	COMMENTS
*[FUNCTION]	OF + A	" <u>0</u> 00000"	Present Offset.
[▶]X4, [▲]X2, [▶], [▼]X5	OF + A	"0000 <u>2</u> 5"	Desired Circular Offset of 25 Counts.
[ENTER]	OF + A	"000025"	Value stored in E <sup>2</sup> PROM. Blinking Cursor removed.

### Auto Zero

The machine is at mechanical zero. You want to reset the transducers' position to 000000. Instead of calculating the required Circular Offset, you can use the Auto Zero feature.

PRESS	IND. LEDS	DISPLAY	COMMENTS
*[FUNCTION]	POS	"xxxxxx"	xxxxxx = Present Position.
[CLEAR]	POS	"000000"	Position reset to zero..
*[FUNCTION]	OF + A	"yyyyyy"	yyyyyy = Calculated Offset

### Linear Offset

In your application, the transducer is used to measure a linear distance between 25.000 meters and 75.000 meters. You decide to program a Scale Factor of 50000 and a Linear Offset of 25000. The default value of 000000 for the Linear Offset is presently in memory. The Auto Zero feature has been used to force the position data to zero.

PRESS	IND. LEDS	DISPLAY	COMMENTS
*[FUNCTION]	OF + B	" <u>0</u> 00000"	Present Linear Offset.
[▶], [▲]X2, [▶], [▲]X5	OF + B	"02 <u>5</u> 000"	Desired Linear Offset of 25000 Counts.
[ENTER]	OF + B	"025000"	Value stored in E <sup>2</sup> PROM. Blinking Cursor removed.
*[FUNCTION]	POS	"025000"	Desired Position Value, Position Values will range from 25000 to 75000.

### Decimal Point

You want to program a decimal point so that the last three digits are after it. The parameter presently has its default setting of zero, (no decimal point).

PRESS	IND. LEDS	DISPLAY	COMMENTS
	POS	" 12345"	Present Position
*[FUNCTION]	A	"d.P. <u>0</u> "	No decimal point on display.
[▲]X3, [ENTER]	A	"d.P. 3"	Value stored in E <sup>2</sup> PROM. Blinking Cursor removed.
*[FUNCTION]	POS	" 12.345"	Three digits to right of decimal point <sup>7</sup> .

# CHP 4: Keyboard Programming

---

*Notes*



THIS CHAPTER EXPLAINS THE VME READ FUNCTION USED BY GE FANUC PROGRAMMABLE CONTROLLERS TO TRANSFER DATA FROM A **SERIES 1960** MODULE AS WELL AS THE **SERIES 1960** DATA FORMAT. IF YOU ARE A **SERIES 1960V** USER, **DO NOT** USE THE INFORMATION IN THIS CHAPTER. INSTEAD, REFER TO CHAPTER 6: SERIES 1960V DATA TRANSFER AND FORMAT.

## VME READ BYTE Function

The VME READ BYTE (VME\_RD\_BYTE) Function is used to read the Position and Tachometer data from the Series 1960 Module to the GE Fanuc CPU. Figure 5.1 shows a VME\_RD Function for a single channel module in a ladder logic rung. The highlighted sections contain information that you must supply when the Function is entered.

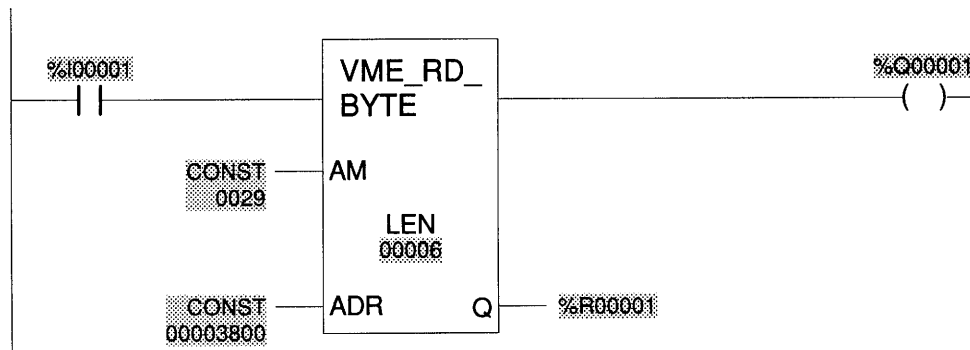

Fig 5.1 GE Fanucs' VME\_READ Function

**NOTE:** There are two VME READ Functions, one for transferring bytes of data, the other for transferring words. The VME\_RD\_WORD Function will not work with the Series 1960 Modules. The VME\_RD\_BYTE Function must be used.

## Parts of the VME\_RD\_BYTE Function

### Contact Input (%I00001)

Any type of contact can be used to enable the VME READ Function. In this example, the 1960 Module will be read by the CPU when contact %I00001 is a logic "1". If you want the 1960 Module to be read by the CPU on every scan, the contact can be omitted.

### Coil Output (%Q00001)

The coil output will become true when the VME READ Function successfully completes. Any type of coil can be used. In this example, coil %Q00001 will become true when the Function successfully completes.

You should use a coil output with the VME READ Function. This will allow you to test the coil at a later point in the scan to be sure that the Function has completed successfully and the data is valid.

## CHP 5: Series 1960 Data Transfer and Format

---

### Parts of the VME\_RD\_BYTE Function (cont'd)

#### AM (Address Modifier) Code

All 1960 Modules are factory configured to respond to the AM Code of 29H. This corresponds to the Standard Short Non-Privileged VME access (16 bit address). The actual AM Code programmed into the VME READ Function depends on the rack that the module resides in. Figure 5.2 lists the AM Codes for the different racks. Note that the AM Code that the module is configured for remains 29H. The GE Fanuc Expansion Module that controls the expansion rack uses the programmed AM Code to determine when it's rack is being accessed and converts the AM Code to 29H before it accesses the modules in it's rack.

Rack	Programmed AM Code	Board Configured AM Code
0	29h	29h
1	1Eh	29h
2	1Dh	29h
3	1Ch	29h
4	1Bh	29h
5	1Ah	29h
6	19h	29h
7	18h	29h

AM Code 1Fh is reserved

Fig 5.2 Address Modifier (AM) Codes

#### LENgth Parameter

The Length Parameter tells the CPU the number of Bytes to transfer from the Series 1960 Module. Figure 5.3 lists the number of bytes that must be transferred from each 1900 Module.

Module Type	# of Bytes
1961	6
1962	12

Fig 5.3 Length Parameter Values



All 1960 Modules use a device called a Dual Port RAM as it's interface to the VME Bus. This device has two banks of RAM. When the module is writing the new Position and Tach values to one bank, the VME Bus has access to the other bank so that it can read the latest, complete information. Once the VME Bus has accessed a bank, the 1960 Module will not switch the banks until the VME Bus has read the LAST Byte of information in the bank. **CONSEQUENTLY, If the Length Parameter is set to a value less than the ones listed above, the VME Bus will NEVER have access to the new Position and Tach Information from the 1960 Module. **You Must Read All Information From The Series 1960 Modules, Even If You Will Only Use Some Of The Available Information In Your Program.****

### Parts of the VME\_RD\_BYTE Function (cont'd)

#### Memory Address

This parameter must be set to the Memory address set by the bank of 5 DIP Switches located on the back of the Module. (See Memory Address Allocation: Pgs 3-1 and 3-2.) You have two choices when allocating memory addresses to the Series 1960 Module. You can choose the default memory addresses used by the GE Fanuc Modules or you can choose a 2K section of the User Defined memory addresses. Figure 5.4 lists the address allocations used by the GE Fanuc Modules and the User Defined Area.

Slot	Address Range	Slot	Address Range
PS	None	5	2800h - 2FFFh
1	None	6	3000h - 37FFh
2	1000h - 17FFh	7	3800h - 3FFFh
3	1800h - 1FFFh	8	4000h - 47FFh
4	2000h - 27FFh	9	4800h - 4FFFh
User Defined 5000h - FFFFh			

Fig 5.4 Address Allocations

#### Q: (Transfer Destination Address)

Q specifies the first location in the CPU user reference into which the data read from the Series 1960 module is to be stored. In this example the information from the 1960 Module will be stored starting at the first Register Memory Address. Note that only 3 Register Memory Words per channel will be used because the Transfer Length is 6 Bytes. (2 Bytes = 1 Word.)

#### Data Byte Significance

As noted in Chapter 5 of the GE Fanuc's GFK-0448A, "User's Guide To Integration of 3rd Party VME Modules" GE Fanuc uses the Intel Convention for storing word data in bytes. In this convention, the least significant byte of data is stored at the even byte location in memory. The VME Standard, and therefore most VME modules including the Series 1960V Modules, use the Motorola Convention of storing the least significant byte of data at the odd byte locations in memory. Because of this difference, you must perform byte, and sometimes word, swapping before the data from a standard VME Module can be used. **THIS DOES NOT HOLD TRUE FOR THE SERIES 1960 MODULES. HOWEVER,** it does hold true if you use a Series 1960V Module in a GE Fanuc system.

Because the Series 1960 Modules use the VMEbus D8(E0) data transfer method, the GE Fanuc CPU will automatically place the bytes of data in their proper location in the memory registers. **BYTE SWAPPING IS NOT NECESSARY WHEN USING A SERIES 1960 MODULE.**

# CHP 5: Series 1960 Data Transfer and Format

---

## Data Format

When a VME READ BYTE Function accesses a Series 1960 Module, the Module transmits eight bytes to the CPU for each of its channels. The first and second bytes contain the three most significant digits of the Position value, the third and fourth contain the three least significant digits of the Position value. The fifth and sixth bytes contain the Tachometer value. Data is always transmitted in Binary format. The order of the words is shown below.

**NOTE:**

- 1961 transmit words 1-3 only      • 1962 transmit words 1-6
- **BYTE SWAPPING IS NOT NECESSARY WHEN USING A SERIES 1960 MODULE**

	ODD BYTE				EVEN BYTE				
Word 1	E*	0	0	0	Upper 3 digits Position Data TRANSDUCER 1				
Word 2	E*	0	0	0	Lower 3 digits Position Data TRANSDUCER 1				
Word 3	E*	0	0	0	0	11 Bit Tachometer Data			TRANSDUCER 1
Word 4	E*	0	0	0	Upper 3 digits Position Data TRANSDUCER 2				
Word 5	E*	0	0	0	Lower 3 digits Position Data TRANSDUCER 2				
Word 6	E*	0	0	0	0	11 Bit Tachometer Data			TRANSDUCER 2

Fig 5.5 Series 1960 Data Format

**NOTES:**

E\* - When there is a fault condition, the hexadecimal number 8000, (1000 0000 0000 0000 BIN), is sent to the CPU in place of the Position and Tachometer values. Fault conditions reported in this way are transducer and E<sup>2</sup>PROM Errors. This is the only time bit 16 is set by the 1960 Module so the bit can be used for efficient error detection. When there is a transducer fault, only the words of the affected transducer are changed. In the case of an E<sup>2</sup>PROM error, all transmitted words are changed. For more information on fault conditions, refer to Status Indicators, Pg 2-5.

Because both the Position and Tachometer values are less than 16 bits in length, both have preceding zeros to complete the 16 bit words.

If you want to convert the Position Data to a continuous 24 bit word use the following formula: ((Word 1) \* 1000 + (Word 2)).

THIS CHAPTER EXPLAINS THE ADDRESSING AND DATA TRANSFER CAPABILITIES OF THE **SERIES 1960V** MODULES AS WELL AS THE **SERIES 1900V** DATA FORMAT. IF YOU ARE A **SERIES 1960** USER, **DO NOT** USE THE INFORMATION IN THIS CHAPTER. INSTEAD, REFER TO CHAPTER 5: SERIES 1960 DATA TRANSFER AND FORMAT.

## Standard VME Systems

GE Fanuc's Series 90<sup>TM</sup>-70 programmable controller system define several User Definable options in the VME protocol. This allowed GE Fanuc to simplify module configurations and system set-ups for the end user. Consequently, AMCI was able to produce a "plug and play" module for the GE Fanuc system that only required setting DIP switches on the rear panel before use. However, there are hundreds, if not thousands, of VME Masters and software programs for VME systems. Therefore it's impossible to write a chapter that covers every possible application for a Series 1960V Module. Instead, this chapter is a technical discussion of Series 1960V Module configurations. It is up to you to determine the correct configuration for your application.

## Data Byte Significance

Series 1960V Modules use the Motorola Convention of storing the least significant byte of data at the odd byte locations in memory. This convention is specified by the VME protocol and is used by all standard VME modules. Series 1960 Modules for the GE Fanuc Series 90<sup>TM</sup>-70 system use the Intel Convention of storing the least significant byte of data at the even byte locations in memory. This convention is specified by the GE Fanuc Series 90<sup>TM</sup>-70 protocol. Therefore, if you use a Series 1960 module in a standard VME system, you must perform byte swapping before the data can be used.

## Addressing Capabilities

A Series 1960V module can be located at any 2K boundary of either the Short (A16) Address space or the Standard (A24) Address space. The address space used by the Series 1960V is set by the AM Code. A Series 1960V module will use 6 bytes of memory for each transducer channel. The first byte used by a module has the address XXXX XX00h. The last byte used is given below.

Module Number	Last Used Memory Address
1961V	XXXX XX05h
1962V	XXXX XX0Bh

Fig 6.1 Last Used Memory Addresses

## D08(E0) Data Transfer

Every Series 1960V Module uses D08(E0) data transfers. Because of this, the data from a Series 1960V Module enters consecutive byte addresses in the VME memory. Position values occupy 2 Words of memory, (4 bytes), and Tachometer values occupy 1 Word. Therefore, four consecutive byte reads are necessary to access one complete Position value and two consecutive byte reads are necessary to access one complete Tachometer value. The least significant byte of a word is located at the odd address and is transferred over D00-D07 data lines. The most significant byte of a word is located at the even address and is transferred over D08-D15 data lines.

## CHP 6: Series 1960V Data Transfer and Format

### Dual Port RAM Bank Switching

Every 1960 Module uses a Dual Port RAM (DPRAM) as its interface to the VMEbus. This DPRAM consists of two "banks" of memory. The 1960 Module controls these two banks. While the 1960 is writing new position and tachometer data into one bank, it gives the VME master access to the other bank. This prevents addressing collisions that could occur if the VME Master tries to read from a memory location while the 1960 Module tries to write to it.

When the 1960 Module finishes writing new values to the DPRAM it will "switch" the banks to give the VME Master access to fresher data *providing* the VME Master has not accessed the older data in the other bank. This prevents bank switching while the VME Master is reading data. Imagine the problems if this precaution was not taken. For example, if the old data is 8191 (1FFFh) and the new data is 0000, switching banks while reading the two bytes of data would result in a value of 7936 (1F00h). Therefore, once the VME Master has accessed its bank, the 1960 will not switch the banks until the LAST memory location used by the 1960 is accessed.



There are no limitations on the order or number of bytes read by the VME Master. **The only limitation on the read sequence is that the last memory location used by the 1960 Module** (See Fig 6.1, Pg 6-1) **MUST be the last location in the read sequence and access to this location MUST occur.** If the last location is not accessed, the Position and Tachometer data will not update.

### Factory AM Code Configuration

Each 1960V Modules is configured at the factory for Short Non-Privileged Access (AM = 29h). As shown in the *Memory Address Allocation* Section of Chapter 3, (Pgs 3-1 and 3-2), DIP switches on the rear panel allow you to locate the module anywhere in the Short (A16) Address space of the VMEbus at 2K boundaries. Module re-configuration is not necessary if you intend to use this Address Modifier.

### Changing the AM Code

If your application requires you to change the AM Code that the module responds to, the 1960V Module must first be opened. Figure 6-2 below illustrates the screws that must be removed to gain access to the jumpers. The remaining figures in this chapter assume that the module is in the orientation shown below.



1960 Modules contain static sensitive devices. All work on a module must be done in a ESD safe environment.

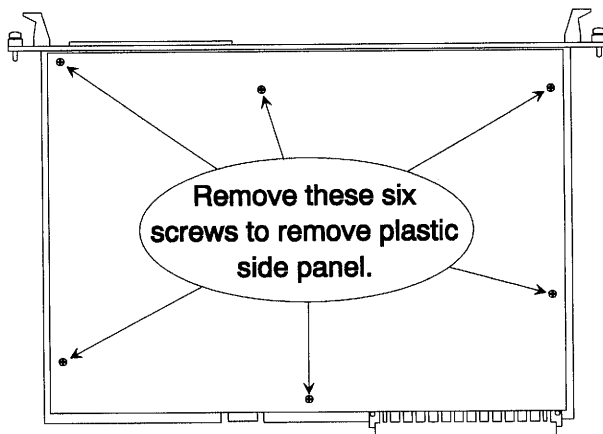

Fig 6.2 1960V Side Panel Removal

## Changing the AM Code (cont'd)

Once the module is opened, you can easily set the AM Code by changing the jumpers on header BJP6, control points BE26-BE28 and control points BE41-BE43. The locations of the header and control points are shown in Figure 6.3. The additional header, BJP7, is used if you configure the module for Standard (A24) addressing.

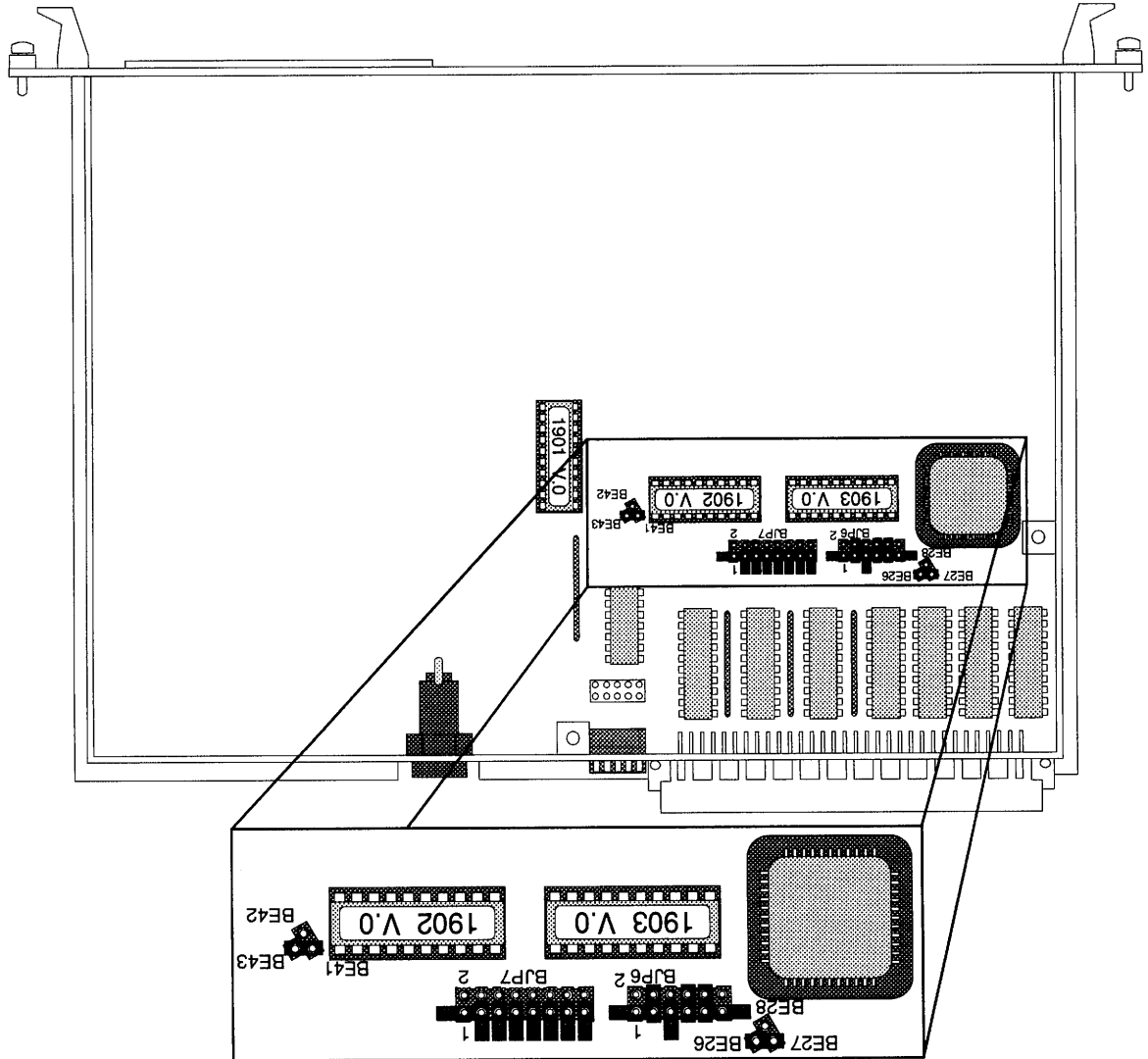

Fig 6.3 AM Code Jumpers

The 12 pin header BJP6 sets the AM Code. Each pair of pins ( (1,2), (3,4), ... , (11,12) ) represent one of the Address Modifier bits as shown in Figure 6.4 below. A jumper placed across a pair of pins represents a binary "0", leaving the pins open represents a binary "1".

Pin Numbers	AM Bit	Pin Numbers	AM Bit
11 - 12	AM0	5 - 6	AM3
9 - 10	AM1	3 - 4	AM4
7 - 8	AM2	1 - 2	AM5

Fig 6.4 BJP6 Pin-out

# CHP 6: Series 1960V Data Transfer and Format

## Changing the AM Code (cont'd)

The jumper on control points BE26-BE28 determines how a Series 1960V module responds to Non-Privileged and Supervisory accesses. If you want the AM Code to determine the type of access, leave the jumper across BE26-BE27. If you want the 1960V to respond to both type of accesses, configure the Module for Non-Privileged access and place the jumper across BE27-BE28.

You must change the jumper on control points BE41-BE43 if you plan to use Standard (A24) addressing. If this jumper is not changed, the 1960V will not decode address lines A16 - A23. This will most likely cause bus contention problems with other modules in your system. If you use Short (A16) addressing with the Module, leave the jumper across BE41-BE43. If you use Standard (A24) addressing, place the jumper across BE41-BE42.

Figure 6.5 gives the jumper settings for the 4 VME Specified AM Codes that the module can be configured for.

AM Code	Transfer Type	Jumpers		
		BJP6	BE26-28	BE41-43
29h	Short Non-Privileged			
2Dh	Short Supervisory			
	Short N.P. and Super.			
39h	Standard Non-Privileged			
3Dh	Standard Supervisory			
	Standard N.P. and Super.			

Fig 6.5 Jumper Settings - VME Specified AM Codes

In addition to the 4 VME Specified AM Codes, a 1960V Module can also be configured for any one of the sixteen User Defined AM Codes specified by the VME protocol. These AM Codes are numbered 10h to 1Fh and the jumper settings are given in Figure 6.6 on the following page. Note that your VME Master must be able to generate these AM Codes. It is your responsibility to correctly set the BE26-BE28 and BE41-BE43 control points. Follow the general guidelines at the top of this page to set the control points.



## Changing the AM Code (cont'd)

AM Code	Jumpers BJP6	AM Code	Jumpers BJP6
10h		18h	
11h		19h	
12h		1Ah	
13h		1Bh	
14h		1Ch	
15h		1Dh	
16h		1Eh	
17h		1Fh	

Fig 6.6 Jumper Settings - User Defined AM Codes

## Setting Standard Memory Addresses (A16 - A23)

If you configure a 1960V Module to use Standard (A24) Addresses, you can locate the module anywhere in the Standard address space of the VMEbus at 2K boundaries. The low order addresses A11 - A15 are set with the DIP Switches located next to the P1 Connector. Switch 1 corresponds to A15, Switch 2 to A14, through Switch 5 to A11. See Fig 3.3 DIP Switch Settings, Pg 3-2, for information on setting these switches. A16 through A23 are set with header BJP7. See Figure 6.3 AM Code Jumpers, Pg 6-3 for the location of the header.

As shown in Figure 6.7 below, pins 1-2 represent A23, pins 3-4 represent A22, through pins 15-16 that represent A16. A jumper placed across a pair represents a binary "0", leaving the pair open represents a binary "1".

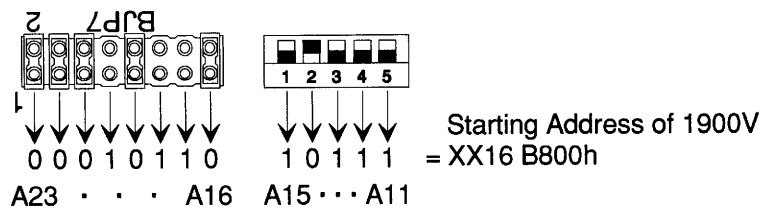

Fig 6.7 Jumper Settings - Standard Address

# CHP 6: Series 1960V Data Transfer and Format

## Data Format

When a VME Master accesses a Series 1960V Module, the Module transmits eight bytes to the CPU for each of its channels. The first and second bytes contain the three most significant digits of the Position value, the third and fourth contain the three least significant digits of the Position value. The fifth and sixth bytes contain the Tachometer value. Data is always transmitted in Binary format. The order of the words is shown below.

**NOTE:**

- 1961 transmit words 1-3 only      • 1962 transmit words 1-6
- BYTE SWAPPING IS NOT NECESSARY WHEN USING A SERIES 1960V MODULE

	EVEN BYTE	ODD BYTE
Word 1	E* 0 0 0	Upper 3 digits Position Data TRANSDUCER 1
Word 2	E* 0 0 0	Lower 3 digits Position Data TRANSDUCER 1
Word 3	E* 0 0 0 0	11 Bit Tachometer Data TRANSDUCER 1
Word 4	E* 0 0 0	Upper 3 digits Position Data TRANSDUCER 2
Word 5	E* 0 0 0	Lower 3 digits Position Data TRANSDUCER 2
Word 6	E* 0 0 0 0	11 Bit Tachometer Data TRANSDUCER 2

Fig 6.8 Series 1960V Data Format

**NOTES:**

E\* - When there is a fault condition, the hexadecimal number 8000, (1000 0000 0000 0000 BIN), is sent to the CPU in place of the Position and Tachometer values. Fault conditions reported in this way are transducer and E<sup>2</sup>PROM Errors. This is the only time bit 16 is set by the 1960V Module so the bit can be used for efficient error detection. When there is a transducer fault, only the words of the affected transducer are changed. In the case of an E<sup>2</sup>PROM error, all transmitted words are changed. For more information on fault conditions, refer to Status Indicators, Pg 2-5.

Because both the Position and Tachometer values are less than 16 bits in length, both have preceding zeros to complete the 16 bit words.

If you want to convert the Position data to a continuous 24 bit value, use the following formula:  
 ((Word 1) \* 1000 + (Word 2)).



DATE	SYM	REVISION RECORD	AUTH	DR	CK

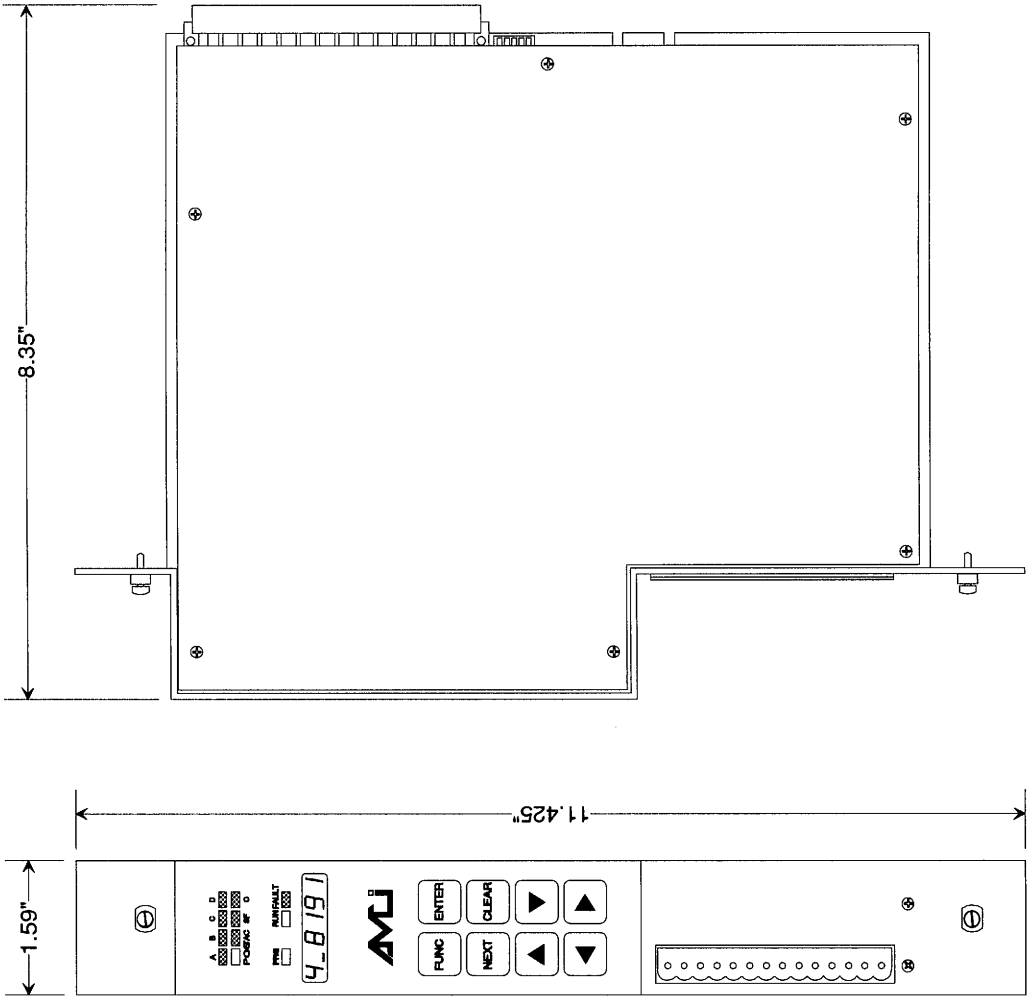

 <b>ADVANCED MICRO CONTROLS INC.</b>	
TOLERANCES (EXCEPT AS NOTED)	SCALE
DECIMAL	DRAWN BY <b>DWN</b>
FRACTIONAL	APPROVED BY
ANGULAR	TITLE <b>Outline Drawing</b>
DATE <b>12/24/91</b>	DRAWING NUMBER <b>B1173</b>

DATE	BY	REVISION RECORD	AUTH	DR	CK

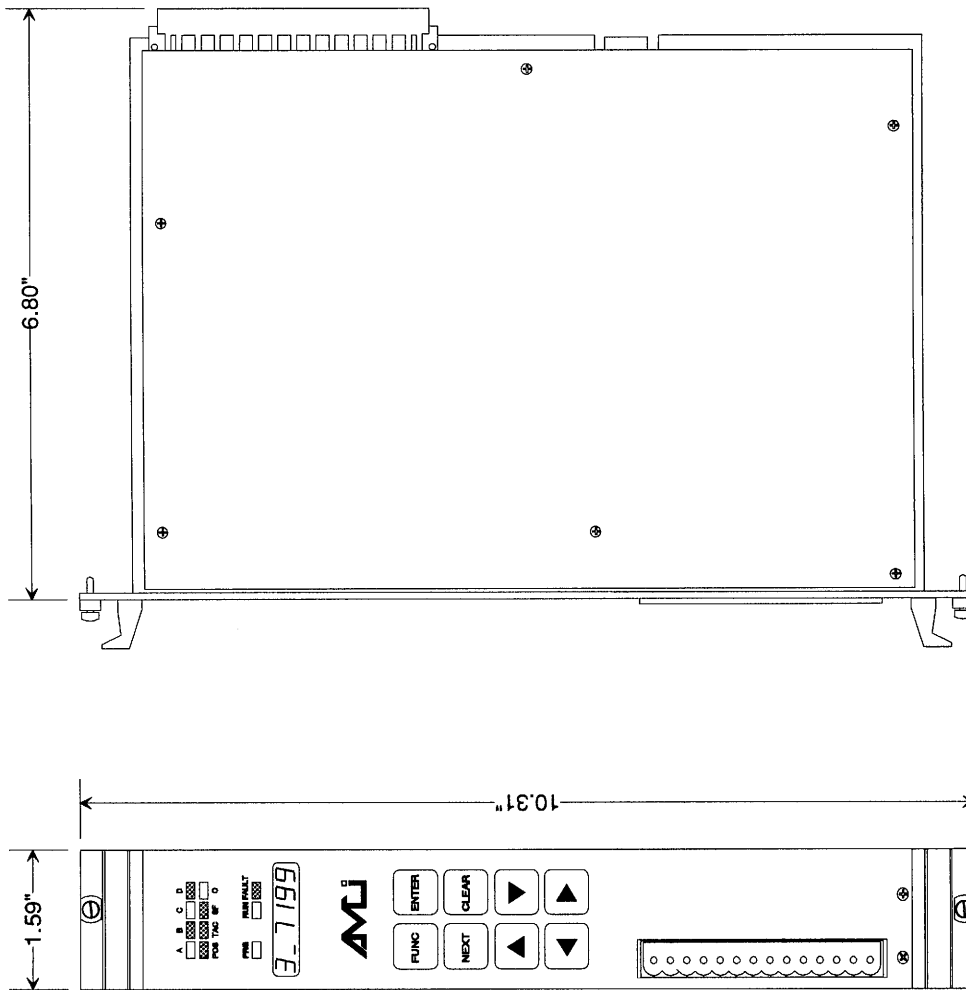

TOLERANCES (EXCEPT AS NOTED)	<b>AMCI</b> ADVANCED MICRO CONTROLS INC.		
DECIMAL	SCALE	DRAWN BY	DWN
FRACTIONAL	None	APPROVED BY	
ANGULAR	TITLE Outline Drawing		
	DATE	DRAWING NUMBER	
	4/21/93	B1197	

DATE	BY/	REVISION RECORD	AUTH.	DR.	CK.
1/93	A	Added Specifications	DWN		

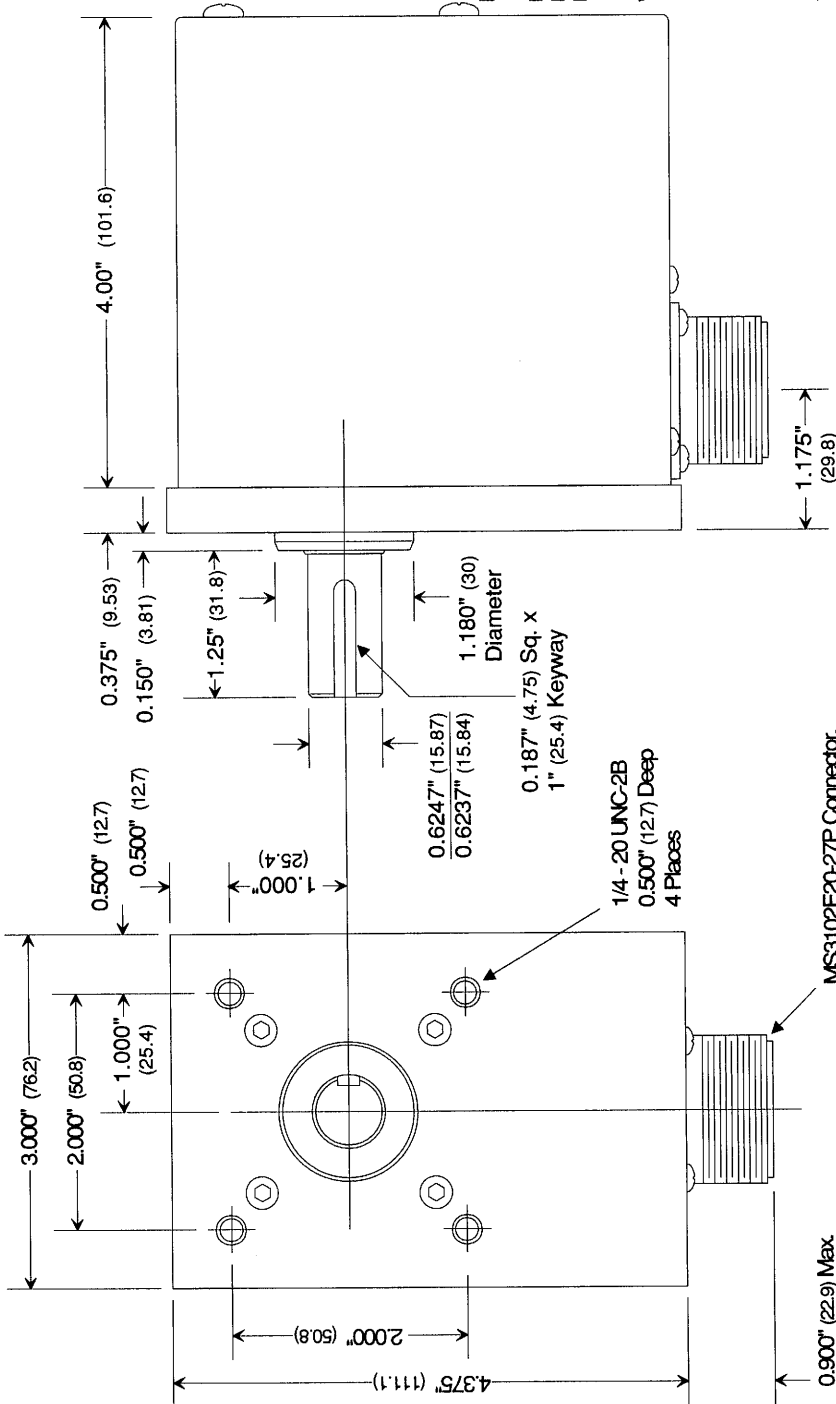

**MECHANICAL SPECIFICATIONS**

Max. Starting Torque @ 25°C ..... 8 oz.in.  
 Moment of Inertia ..... 20 oz-in-sec<sup>2</sup>  
 Max. Shaft Loading:  
 Radial ..... 400 lbs.  
 Axial ..... 200 lbs.  
 Weight ..... 3 lbs.

**ENVIRONMENTAL SPECIFICATIONS**

Operating Temperature ..... -20 to 125°C.  
 Shock ..... 50 G's for 11 mSec.  
 Vibration ..... 5 to 2000 Hz @ 20 G's  
 Nema Rating ..... Nema 13

TOLERANCES (EXCEPT AS NOTED)	<b>AMC</b> ADVANCED MICRO CONTROLS INC.		
DECIMAL	HIT-20(X)	SCALE	DRAWN BY DWN
FRACTIONAL	(X) = Full Scale TUNTS	1:1	APPROVED BY
ANGULAR	TITLE OUTLINE DRAWING		
	DATE 6/1/87	DRAWING NUMBER	B1016 REV. A

DATE	BY	REVISION RECORD	AUTH	DR	CK
3/93	A	Added 1460/1960 Note			

Module Connector  
 Mates with all AMCI Single Channel Multi-turn Absolute Resolver Products  
 AMCI Part #: MS-8  
 Phoenix #: MSTB 1.5/8-ST-5.08

→ BELDEN 9731 Cable.

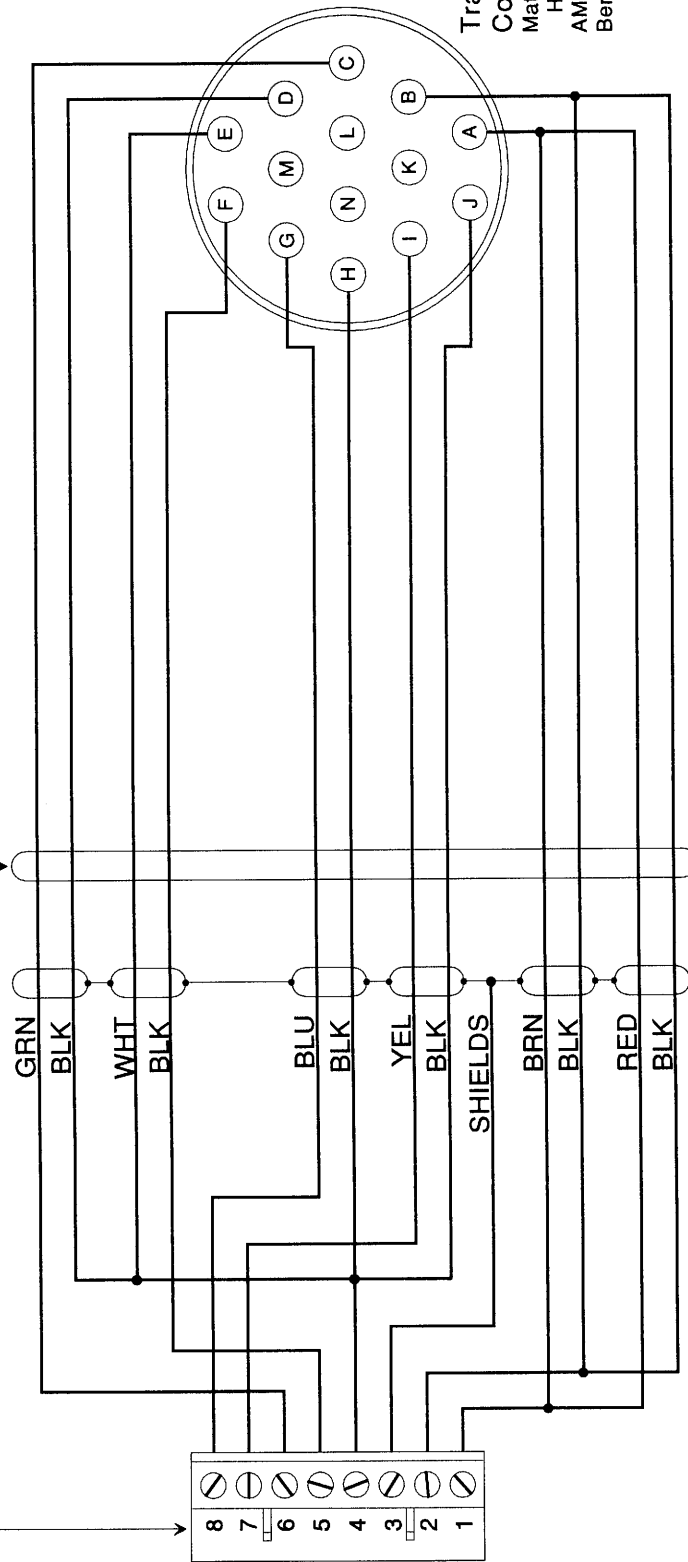

Transducer Connector  
 Mates with:  
 HTT-20-(X) B1016  
 AMCI Part #: MS-20  
 Bendix #:  
 MS3106A20-27S

Connections are shown for CW increasing readings  
 For CCW increasing readings, reverse GRN/BLK Pair (Pins C&D),  
 and BLU/BLK Pair (Pins G&H).

1460/1960 Users:  
 Pin 1 of the Transducer Input Connector is located towards the top of the module, NOT the bottom as this drawing may imply. Reversing the wires on the Module Connector will not harm the module or the transducer, but the transducer will not operate. **IF YOUR MODULE HAS THE REMOTE DISPLAY OPTION**, the cable must be a CTTW-(X). Refer to Print B1190.

TOLERANCES EXCEPT AS NOTED	DECIMAL	SCALE	DRAWN BY	APPROVED BY
		None	DMW	
FRACTIONAL		TITLE		
ANGULAR		DRAWING NUMBER		
		DATE	REV. A	
		5/23/86	B1040	



CTT-(X)  
 (X) = Length in Feet

Transducer Cable Drawing

B1040 REV. A

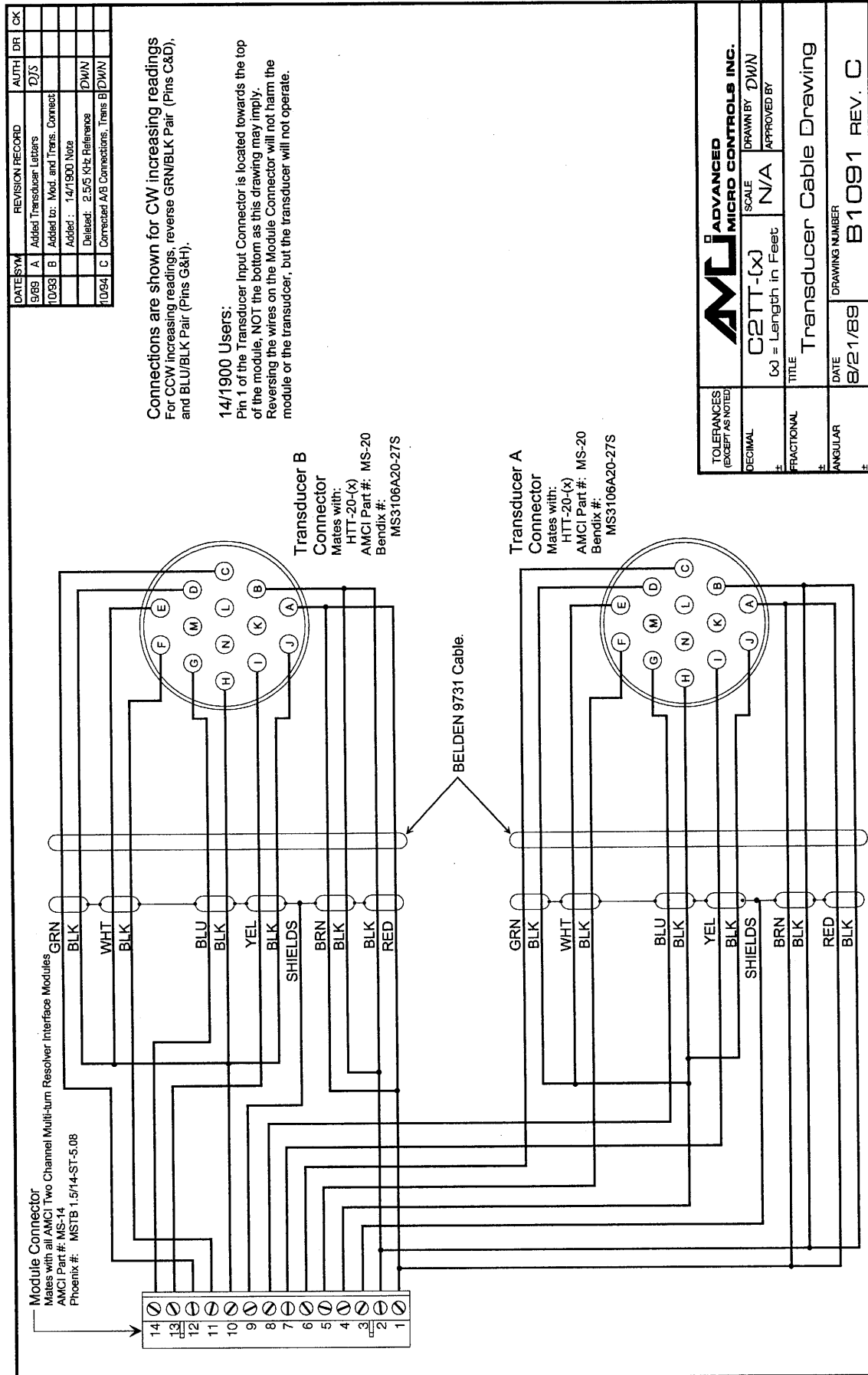

DATE/SYM	REVISION RECORD	AUTH	DR	CK
9/69	A Added Transducer Letters	DJS		
10/93	B Added to: Mod. and Trans. Connect			
	Added: 14/1900 Note	DWN		
	Deleted: 2.5/5 KHz Reference	DWN		
10/84	C Connected A/B Connections, Trans B	DWN		

**Connections are shown for CW increasing readings**  
 For CCW increasing readings, reverse GRN/BLK Pair (Pins C&D), and BLU/BLK Pair (Pins G&H).

**14/1900 Users:**  
 Pin 1 of the Transducer Input Connector is located towards the top of the module, NOT the bottom as this drawing may imply. Reversing the wires on the Module Connector will not harm the module or the transducer, but the transducer will not operate.

<b>AMCI ADVANCED MICRO CONTROLS INC.</b>	
TOLERANCES (EXCEPT AS NOTED)	SCALE
DECIMAL	N/A
FRACTIONAL	APPROVED BY
ANGULAR	TITLE
	Transducer Cable Drawing
DATE	DRAWING NUMBER
8/21/89	B1091 REV. C





**AMCI** *ADVANCED  
MICRO CONTROLS INC.*

PLYMOUTH INDUSTRIAL PARK, TERRYVILLE, CT 06786  
TEL. (203) 585-1254 FAX. (203) 584-1973