

DC425 Gas Tube Arrestor Outline Drawing

RELIANCE 210VSR2
Gas Tube Arrestors
or exact equivalent.
Shown with cover
installed. Allow 2.5" (64)
clearance for installation.

Access Holes (2 Places)
For access to flexible shaft coupler.
Oiflex #52005990 Dummy
Plugs and #52005750 O-Rings
supplied with transducer.

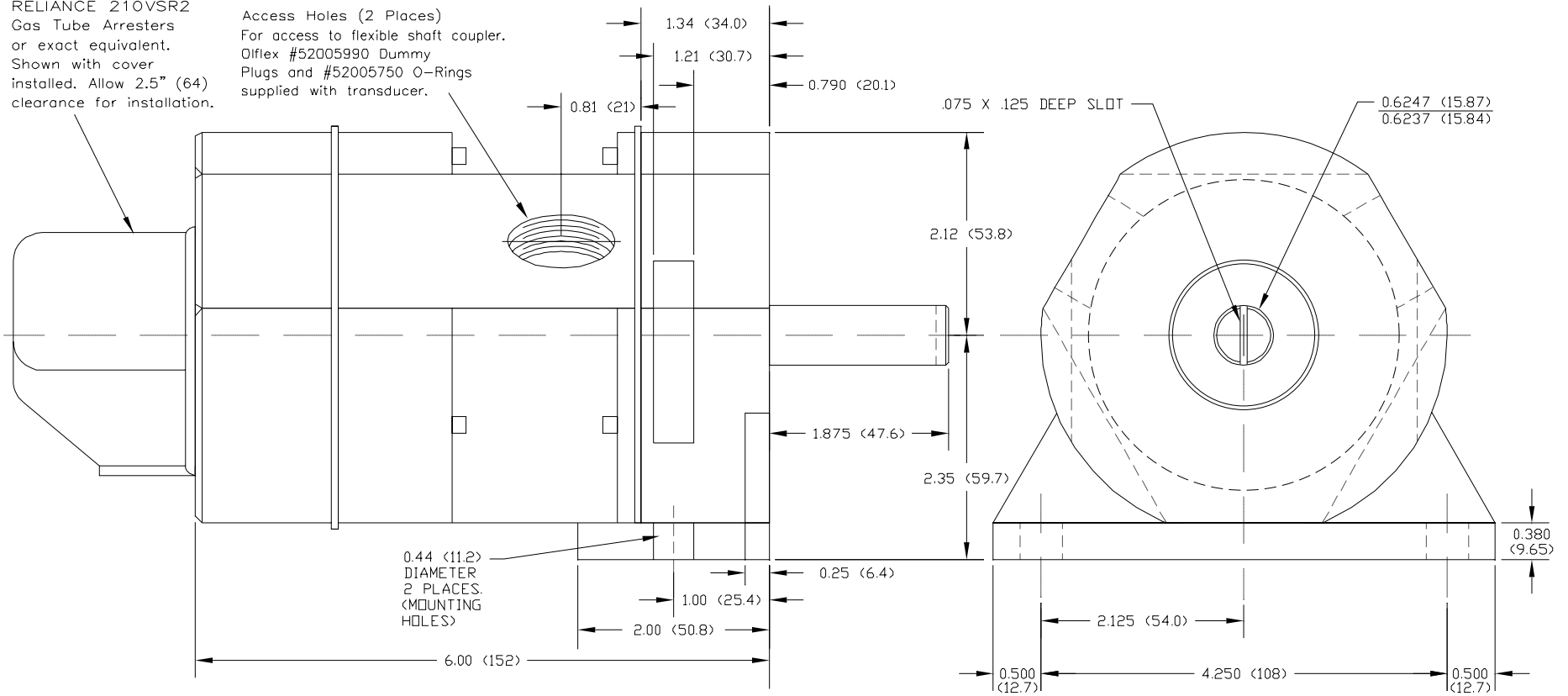

DC425 Side MS Connector Outline Drawing

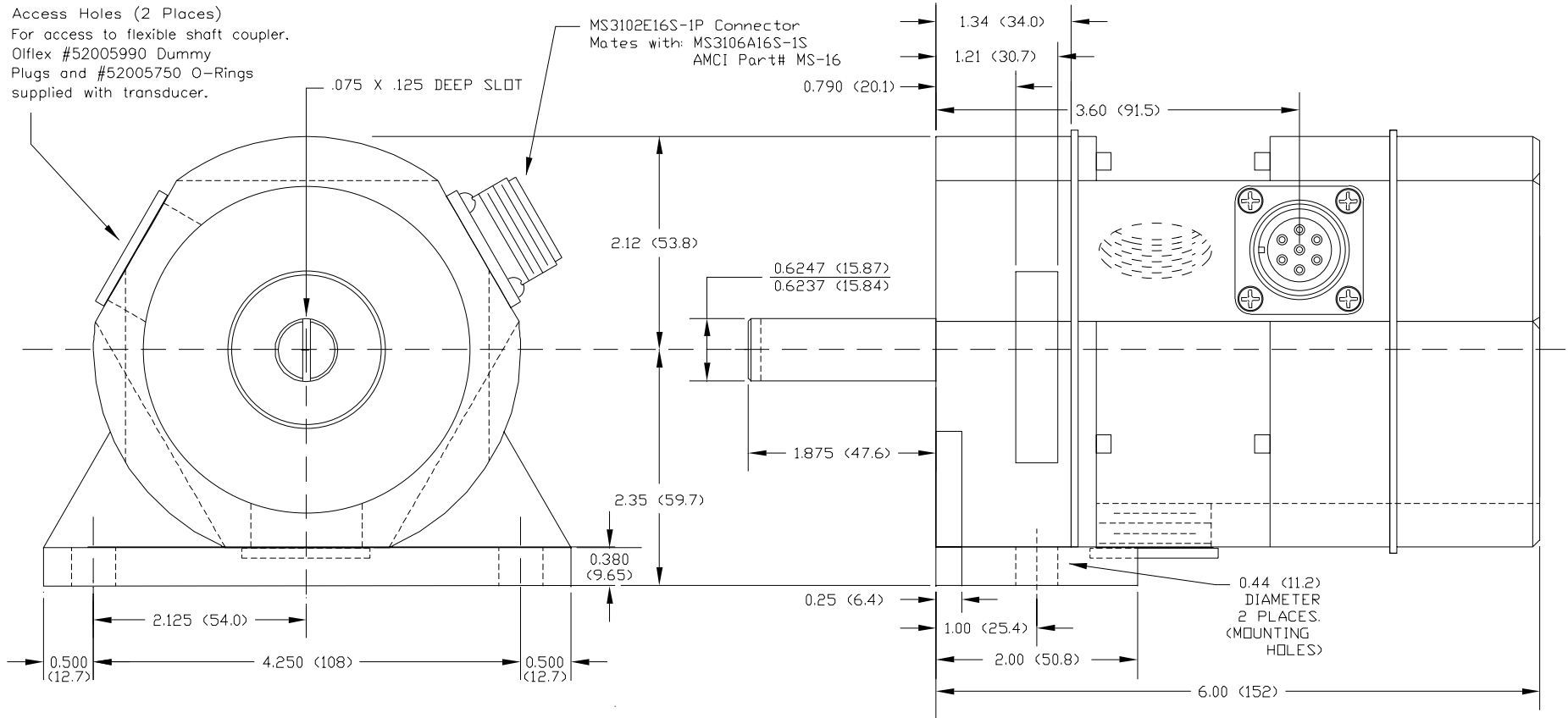

DC425 End MS Connector Outline Drawing

