

Specification Sheet

H25-SS-R1A, H25-SS-R2A, & H25-SS-R3A

SHEET # 940-2T601

DESCRIPTION

The H25-SS-R1A, H25-SS-R2A, and H25-SS-R3A are AMCI size 25, servo mount, single turn transducers with side connectors that are mechanical and electrical replacements for Allen-Bradley's 846-SJHA2CG-R1, 846-SJHA2CG-R2, and 846-SJHA2CG-R3 Industrial Resolvers. Physically identical, the only difference is the resolver embedded in the transducer. Their IP64 rating means they will survive most industrial applications including washdowns.

Several variations of this package, that do not have Allen-Bradley equivalents, are available as special orders. The first option is a shaft seal that raises the environmental rating from IP64 to IP67. The other options are three different shaft sizes, including 1/4 inch, 10 mm, and 3/8 inch with a 3mm keyway. For additional information on these options, contact the factory through our general sales e-mail account; sales@amci.com, or directly at (860) 585-1254 from 8AM to 5PM EST, Monday through Friday.

For additional information on all products available from AMCI, visit our website, www.amci.com.

PRODUCT COMPATIBILITY

AMCI Part Number	Harowe Equ.	Commonly Used With
H25-SS-R1A	11BRW-300-F	IMC-120™, IMC-123™ & 8200 CNC
H25-SS-R2A	11BRCX-300-C	8600 CNC, Creonics Resolver Modules
H25-SS-R3A	11BRCX-300-J1	All AMCI Resolver Products

DIMENSIONAL DRAWING

() = Dimensions in millimeters

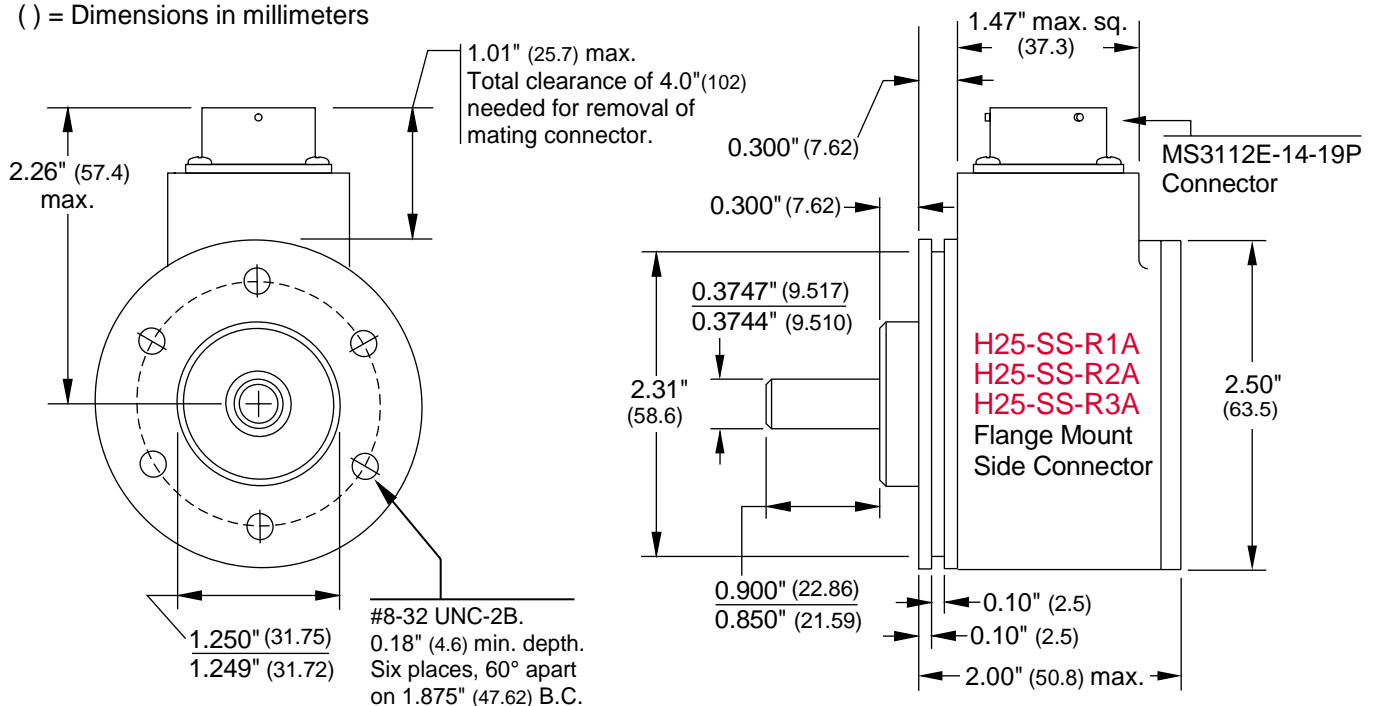

H25-SS-R1A, -R2A, & -R3A Specification Sheet

SPECIFICATIONS

"R1A" ELECTRICAL

Resolver Type: Control Transformer
Primary: Stator
Input Voltage: 12.0 V
Input Freq: 2500 Hz
Input Current: 20.0 mA Max.
Output Voltage: 6.00 V Nom.
Trans. Ratio (TR): 0.50 ± 5%
Accuracy: ± 12 min. (max error)

"R2A" ELECTRICAL

Resolver Type: Transmitter
Primary: Rotor
Input Voltage: 6.0 V
Input Freq: 1000 Hz
Input Current: 20.0 mA Max.
Output Voltage: 2.7 V Nom.
Trans. Ratio (TR): 0.45 ± 5%
Accuracy: ± 12 min. (max error)

"R3A" ELECTRICAL

Resolver Type: Transmitter
Primary: Rotor
Input Voltage: 7.0 V
Input Freq: 5000 Hz
Input Current: 20.0 mA Max.
Output Voltage: 6.65 V Nom.
Trans. Ratio (TR): 0.95 ± 5%
Accuracy: ± 12 min. (max error)

MECHANICAL

Shaft Loading: Radial: 40 lbs. max.
Axial: 20 lbs. max.
Starting Torque: 1.5 oz.in. @ 25°C
Moment of Inertia: 6.00X10⁻⁴ oz-in-sec² max.
Weight: 1 lb.

ENVIRONMENTAL

Shock: 50 g's for 11 mSec
Vibration: 15 g's to 2000 Hz
Operating Temp: -20 to 125°C
Enclosure: IP64
Powder Coat
Aluminum Body
303 Stainless Steel Shaft

IP67 available as option-
Consult factory.

IP Ratings: 6 = Totally protected
against dust.

AND: 4 = Protected against
sprays from all
directions.

OR: 7 = Protected against the
effects of temporary
immersion between
15cm and 1m.

CONNECTOR PINOUT

The figure below shows the connector pinout to industry standard designations and wire colors. Mating connectors available from AMCI are also given.

Female Mating Connector	AMCI Part #
MS3112F14-19S STRAIGHT	MS-19

AMP CONNECTOR: MS3112E14-19P

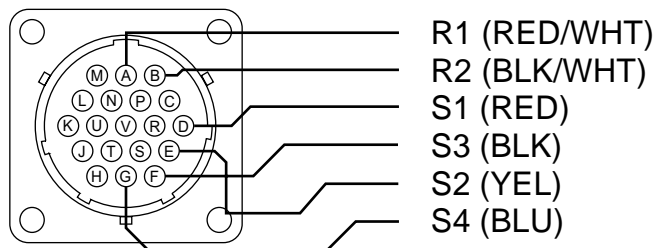

FOR MORE INFORMATION

If you need more information on the H25-SS-R1A, -R2A, or -R3A, use these three resources:

- * If you have internet access, check our website at <http://www.amci.com>. We've worked hard to make our site the repository of information you need to specify and use AMCI products. New product news, product specifications, compatibility tables, application notes, and PDF manuals are all available 24 hours a day.
- * You can also call AMCI for sales or technical support at (860) 585-1254 from 8AM to 5PM EST, Monday through Friday. An applications engineer will be available to assist you.
- * Finally, you can e-mail us at sales@amci.com or techsupport@amci.com.