

H25-M1E Specification Sheet

SHEET # 940-2T740

DESCRIPTION

The H25-M1E is an AMCI size 25, single turn transducer with an end connector. Its mounting flange allows it to be directly mounted to various motors for position and velocity feedback. Its IP 67 rating means it will survive most industrial applications including washdowns. Because this transducer is a resolver instead of an optical encoder, it can be used in harsh applications where an optical encoder cannot even be considered.

The H25-M1E ships with a helical shaft coupler which allows you to couple the transducer to a 3/8" motor shaft. The unit also ships with three plugs in the access holes shown in the dimensional drawing below.

Because the H25-M1E is an absolute sensor, it cannot "lose counts" as an incremental transducer can. If the H25-M1E appears to be losing counts when operating, the usual cause is a shaft slipping in a loose coupler.

DIMENSIONAL DRAWING

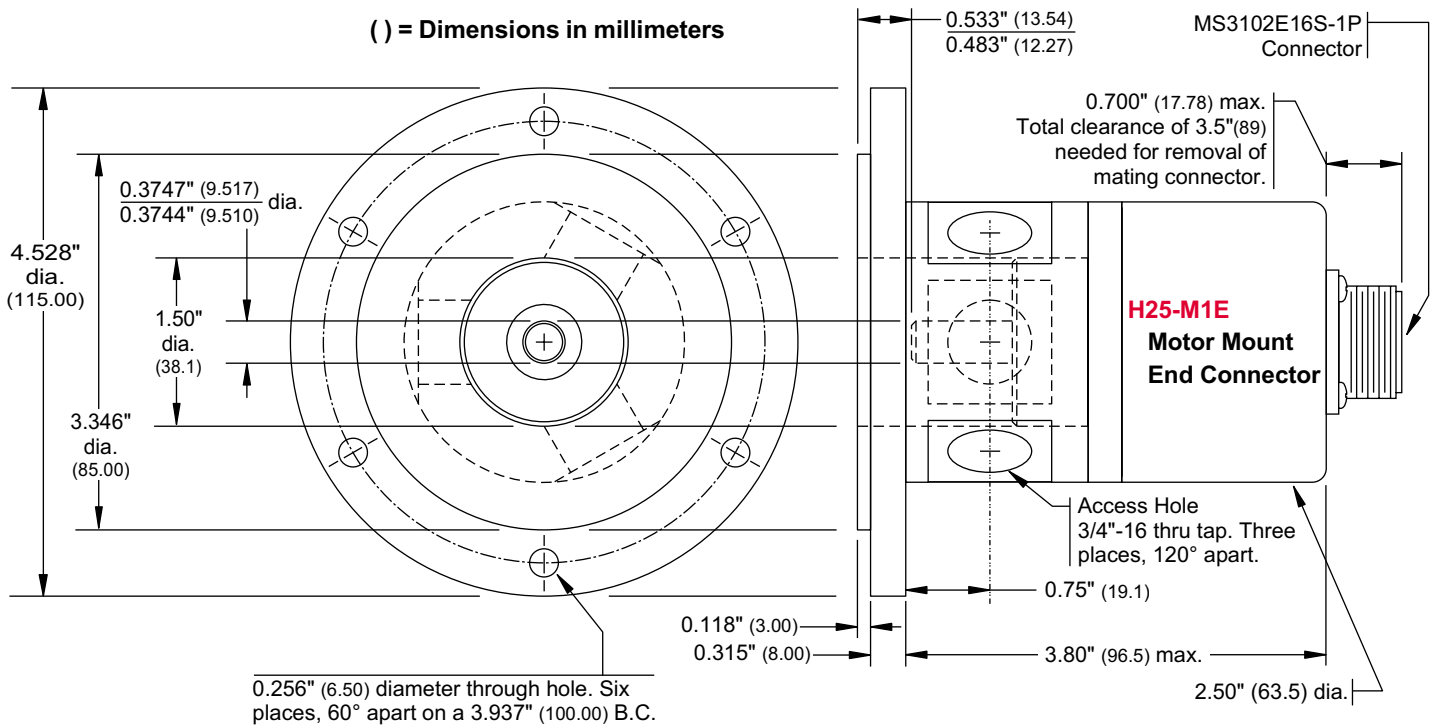

Shaft Coupler included with transducer
Helical Part Num. ACR-100-12-12
<http://www.heli-cal.com>

0.375" (9.53) dia.
Both ends.

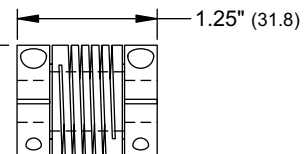
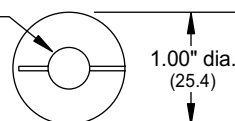

H25-M1E Specification Sheet

CONNECTOR PINOUT

The figure below shows the connector pinout to industry standard designations and wire colors. Mating connectors available from AMCI are also given.

BENDIX CONNECTOR: MS3102E16S-1P

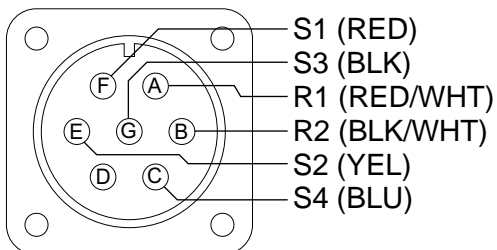

Female Mating Connector AMCI Part #

MS3106A16S-1S	STRAIGHT	MS-16
MS3108A16S-1S	RT. ANGLE	MS-18
MS3106F16S-1S	WATERTIGHT	MS-161

SPECIFICATIONS

ELECTRICAL

Input Voltage: 7.0 V
Input Freq: 5000 Hz
Primary: Rotor
Input Current: 20.0 mA Max.
Output Voltage: 6.65 V Nom.
Trans. Ratio (TR): $0.95 \pm 5\%$
Accuracy: ± 12 min. (max error)

MECHANICAL

Shaft Loading: Radial: 40 lbs. max[†].
Axial: 20 lbs. max[†].
Starting Torque: 2.0 oz.in. @ 25°C
Moment of Inertia: 6.00×10^{-4} oz-in-sec² max.
Weight: 2.3 lb.
[†] Bearing life rated at 2×10^9 revolutions min.
at maximum shaft load.

ENVIRONMENTAL

Shock: 50 g's for 11 mSec
Vibration: 15 g's to 2000 Hz
Operating Temp: -20 to 125°C
Enclosure: IP 67
Power Coated
Aluminum Body
303 Stainless Steel Shaft
Nitrile Shaft Seal

FOR MORE INFORMATION

If you need more information on the H25-M1E use these three resources:

- * If you have internet access, check our website at <http://www.amci.com>. We've worked hard to make our site the repository of information you need to specify and use AMCI products. New product news, product specifications, compatibility tables, application notes, and PDF manuals are all available 24 hours a day.
- * You can also call AMCI for sales or technical support at (860) 585-1254 from 8AM to 5PM EST, Monday through Friday. An applications engineer will be available to assist you.
- * Finally, you can e-mail us at sales@amci.com or techsupport@amci.com.