

H25-FE Specification Sheet

SHEET # 940-2T144

DESCRIPTION

The H25-FE is an AMCI size 25, flange mount, single turn transducer with an end connector that is a bolt-in replacement for most flange mount optical encoders. Its IP 67 rating means it will survive most industrial applications including washdowns. Because this transducer is a resolver instead of an optical encoder, it can be used in harsh applications where an optical encoder cannot even be considered.

The outline drawing below details our standard unit with a 3/8" shaft. This transducer is also available with a 1/4" or 10mm shaft or a 3/8" shaft with a three millimeter keyway under the following part numbers. Dimensional drawings of these shafts are on the next page.

- H25-FE-03: 1/4" Dia. Shaft
- H25-FE-06: 3/8" Dia. Shaft with 3mm Keyway
- H25-FE-10: 10mm Dia. Shaft

Because the H25-FE is an absolute sensor, it cannot "lose counts" as an incremental transducer can. If the H25-FE appears to be losing counts when operating, the usual cause is a shaft slipping in a loose coupler.

SPECIFICATIONS

ELECTRICAL

- Input Voltage: 7.0 V
- Input Freq: 5000 Hz
- Primary: Rotor
- Input Current: 20.0 mA Max.
- Output Voltage: 6.65 V Nom.
- Trans. Ratio (TR): 0.95 ± 5%
- Accuracy: ± 12 min. (max error)

MECHANICAL

- Shaft Loading: Radial: 40 lbs. max[†].
Axial: 20 lbs. max[†].
- Starting Torque: 2.0 oz.in. @ 25°C
- Moment of Inertia: 6.00X10⁻⁴ oz-in-sec² max.
- Weight: 1.3 lb.
- [†] Bearing life rated at 2X10⁹ revolutions min. at maximum shaft load.

ENVIRONMENTAL

- Shock: 50 g's for 11 mSec
- Vibration: 15 g's to 2000 Hz
- Operating Temp: -20 to 125°C
- Enclosure: IP 67
- Power Coated
- Aluminum Body
- 303 Stainless Steel Shaft
- Nitrile Shaft Seal

DIMENSIONAL DRAWING

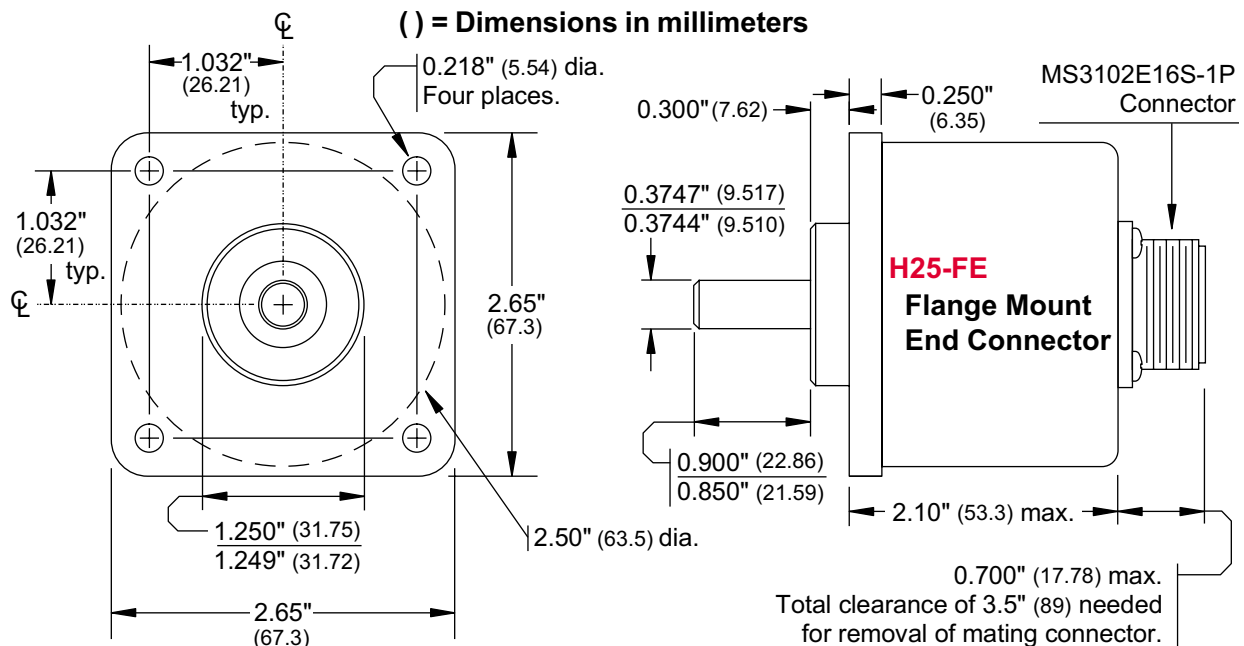

H25-FE Specification Sheet

CONNECTOR PINOUT

The figure below shows the connector pinout to industry standard designations and wire colors. Mating connectors available from AMCI are also given.

BENDIX CONNECTOR: MS3102E16S-1P

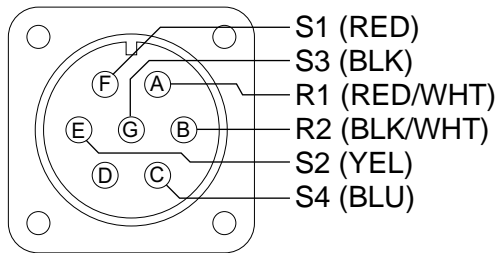

Female Mating Connector	AMCI Part #
MS3106A16S-1S STRAIGHT	MS-16
MS3108A16S-1S RT. ANGLE	MS-18
MS3106F16S-1S WATERTIGHT	MS-161

ALTERNATE SHAFT DETAIL

-03 Shaft

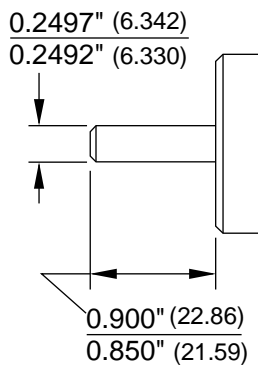

-06 Shaft

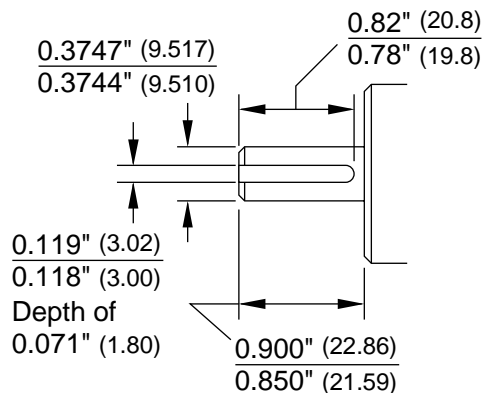

-10 Shaft

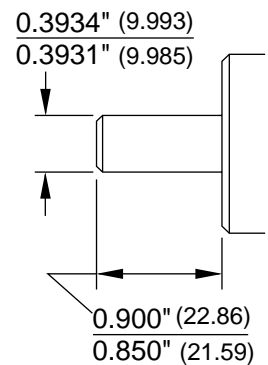

FOR MORE INFORMATION

If you need more information on the H25-FE use these three resources:

- * If you have internet access, check our website at <http://www.amci.com>. We've worked hard to make our site the repository of information you need to specify and use AMCI products. New product news, product specifications, compatibility tables, application notes, and PDF manuals are all available 24 hours a day.
- * You can also call AMCI for sales or technical support at (860) 585-1254 from 8AM to 5PM EST, Monday through Friday. An applications engineer will be available to assist you.
- * Finally, you can e-mail us at sales@amci.com or techsupport@amci.com.