

RD750

Resolver Feedback Option Module

**for
PowerFlex[®] 750-Series Drives**

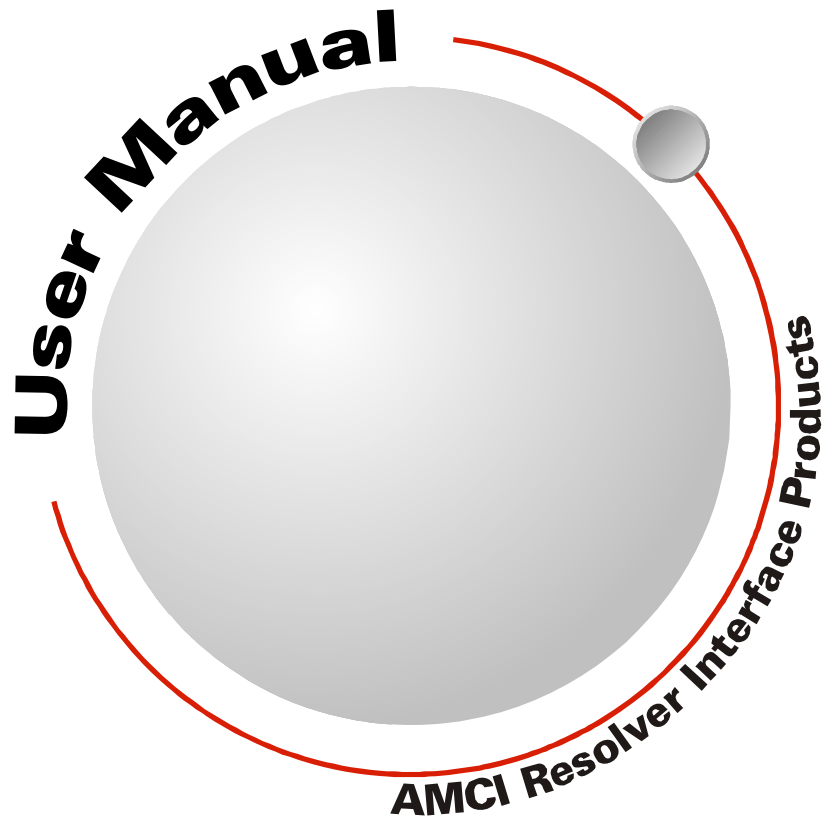

GENERAL INFORMATION

Important User Information

The products and application data described in this manual are useful in a wide variety of different applications. Therefore, the user and others responsible for applying these products described herein are responsible for determining the acceptability for each application. While efforts have been made to provide accurate information within this manual, AMCI assumes no responsibility for the application or the completeness of the information contained herein.

UNDER NO CIRCUMSTANCES WILL ADVANCED MICRO CONTROLS, INC. BE RESPONSIBLE OR LIABLE FOR ANY DAMAGES OR LOSSES, INCLUDING INDIRECT OR CONSEQUENTIAL DAMAGES OR LOSSES, ARISING FROM THE USE OF ANY INFORMATION CONTAINED WITHIN THIS MANUAL, OR THE USE OF ANY PRODUCTS OR SERVICES REFERENCED HEREIN.

No patent liability is assumed by AMCI, with respect to use of information, circuits, equipment, or software described in this manual.

The information contained within this manual is subject to change without notice.

This manual is copyright 2013 by Advanced Micro Controls Inc. You may reproduce this manual, in whole or in part, for your personal use, provided that this copyright notice is included. You may distribute copies of this complete manual in electronic format provided that they are unaltered from the version posted by Advanced Micro Controls Inc. on our official website: www.amci.com. You may incorporate portions of this documents in other literature for your own personal use provided that you include the notice "Portions of this document copyright 2013 by Advanced Micro Controls Inc." You may not alter the contents of this document or charge a fee for reproducing or distributing it.

Standard Warranty

ADVANCED MICRO CONTROLS, INC. warrants that all equipment manufactured by it will be free from defects, under normal use, in materials and workmanship for a period of [18] months. Within this warranty period, AMCI shall, at its option, repair or replace, free of charge, any equipment covered by this warranty which is returned, shipping charges prepaid, within eighteen months from date of invoice, and which upon examination proves to be defective in material or workmanship and not caused by accident, misuse, neglect, alteration, improper installation or improper testing.

The provisions of the "STANDARD WARRANTY" are the sole obligations of AMCI and excludes all other warranties expressed or implied. In no event shall AMCI be liable for incidental or consequential damages or for delay in performance of this warranty.

Returns Policy

All equipment being returned to AMCI for repair or replacement, regardless of warranty status, must have a Return Merchandise Authorization number issued by AMCI. Call (860) 585-1254 with the model number and serial number (if applicable) along with a description of the problem during regular business hours, Monday through Friday, 8AM - 5PM Eastern. An "RMA" number will be issued. Equipment must be shipped to AMCI with transportation charges prepaid. Title and risk of loss or damage remains with the customer until shipment is received by AMCI.

24 Hour Technical Support Number

24 Hour technical support is available on this product. If you have internet access, start at www.amci.com. Product documentation and FAQ's are available on the site that answer most common questions.

If you require additional technical support, call (860) 583-7271. Your call will be answered by the factory during regular business hours, Monday through Friday, 8AM - 5PM Eastern. During non-business hours an automated system will ask you to enter the telephone number you can be reached at. Please remember to include your area code. The system will page an engineer on call. Please have your product model number and a description of the problem ready before you call.

We Want Your Feedback

Manuals at AMCI are constantly evolving entities. Your questions and comments on this manual are both welcomed and necessary if this manual is to be improved. Please direct all comments to: Technical Documentation, AMCI, 20 Gear Drive, Terryville CT 06786, or fax us at (860) 584-1973. You can also e-mail your questions and comments to techsupport@amci.com

TABLE OF CONTENTS

General Information

Important User Information	2
Standard Warranty	2
Returns Policy	2
24 Hour Technical Support Number	2
We Want Your Feedback	2

About this Manual

Audience	5
Trademark Notices	5
Revision Record	5
Previous Revisions	5
Navigating this Manual	5
Manual Conventions	6
Where To Go From Here	6

Introduction to the RD750

The RD750	7
R-D Converter	7
Encoder Output	8
Software Configuration	8
Additional Notes on	
Reversing Count Direction	9
Status LED's	10
LED1: Host Drive	
Connection State	10
LED2: Resolver State	11
Compatible Sensors	12
Resolver Transmitters	12
Resolver Control Transformers	12
Single and Multi-Speed	
Resolvers	13
Resolver Tracking Speed	13

Specifications

RD750 Specifications	14
----------------------------	----

Installing the RD750

Setting Encoder Jumper and	
DIP Switches	15
RD750 Orientation	15
Setting the Encoder Jumper	15
DIP Switch Settings	16
Settings for Common Resolvers ..	17
Determining Settings for	
Other Resolvers	17
Frequency Setting	17
TR Setting for Transmitter	
Resolvers	18
TR Setting for Control	
Transformer Resolvers	18
Installing the RD750	19
Wiring the Resolver Input	20
Reversing Count Direction	20
Encoder Output Wiring	20
Determining the TR Setting of a	
Control Transformer Resolver	21
With a True RMS	
Meter or Scope	21
With the Resolver	
Status LED (LED2)	21

Option Module Parameters

Parameter List	22
----------------------	----

Troubleshooting

Faults and Alarms	25
-------------------------	----

Software Configuration

Drive Add On Profiles	26
Integrated Motion	26
Connected Components Workbench	26
DriveTools / DriveExecutive	26

Notes

ABOUT THIS MANUAL

Read this chapter to learn how to navigate through this manual and familiarize yourself with the conventions used in it. The last section of this chapter highlights the manual's remaining chapters and their target audience.

Audience

This manual explains the set-up, installation, and operation of AMCI's RD750 Resolver Feedback Option Module for the Allen-Bradley PowerFlex 750-Series AC Drives. It is written for the engineer responsible for incorporating these modules into a design, as well as the engineer or technician responsible for its actual installation.

Trademark Notices

The AMCI logo is a trademark of Advanced Micro Controls Inc.

All other trademarks contained herein are the property of their respective holders.

Revision Record

This manual, 940-0E013, is the fourth release of this manual. It adds additional information about not removing or installing the resolver connector under power. It was initially released on November 13th, 2013.

Previous Revisions

940-0E012: Third Release. 9/16/2013. Added information on the encoder emulator and its outputs.

940-0E011: Second Release. 9/3/2013. Added information on using control transformer resolvers.

940-0E010: Initial Release. 8/15/2013.

Navigating this Manual

This manual is designed to be used in both printed and on-line formats. Its on-line form is a PDF document, which requires Adobe Acrobat Reader version 7.0+ to open it. Bookmarks of all the chapter names, section headings, and sub-headings were created in the PDF file to help navigate it. The bookmarks should have appeared when you opened the file. If they didn't, press the F5 key on Windows platforms to bring them up.

Throughout this manual you will find *blue text that functions as a hyperlink* in HTML documents. Clicking on the text will immediately jump you to the referenced section of the manual. If you are reading a printed manual, most links include page numbers. You will also find *red text that functions as a hyperlink*. These links will bring you to the AMCI website. Note that after clicking on a red link, the program may ask for confirmation before connecting to the Internet.

The PDF file is password protected to prevent changes to the document. You are allowed to select and copy sections for use in other documents and, if you own Adobe Acrobat version 7.0 or later, you are allowed to add notes and annotations.

Manual Conventions

Three icons are used to highlight important information in the manual:



NOTES highlight important concepts, decisions you must make, or the implications of those decisions.



CAUTIONS tell you when equipment may be damaged if the procedure is not followed properly.



WARNINGS tell you when people may be hurt or equipment may be damaged if the procedure is not followed properly.

The following table shows the text formatting conventions:

Format	Description
Normal Font	Font used throughout this manual.
<i>Emphasis Font</i>	Font used the first time a new term is introduced.
<i>Cross Reference</i>	When viewing the PDF version of the manual, clicking on the cross reference text jumps you to referenced section.
<i>HTML Reference</i>	When viewing the PDF version of the manual, clicking on the HTML reference text will open your default web browser to the referenced web page.

Where To Go From Here

This manual contains information that is of interest to everyone from engineers to operators. The table below gives a brief description of each section's contents to help you find the information you need to do your job.

Section Title	Starting Page	Intended Audience
<i>Introduction to the RD750</i>	7	Anyone new to the RD750 Resolver Feedback Option Module. This section gives a basic overview of the features available on the unit and status LED blink patterns.
<i>Specifications</i>	14	Specifications table for the RD750.
<i>Installing the RD750</i>	15	Anyone that must install an RD750. Includes information on DIP switch settings, mounting, grounding, and wiring.
<i>Option Module Parameters</i>	22	Anyone that needs a listing of the parameters available when using the 20-750-ENC-1 software profile and how the RD750 uses these settings.
<i>Troubleshooting</i>	25	Anyone that needs a listing of the fault codes available when using the 20-750-ENC-1 software profile and when the RD750 will generate these codes.
<i>Software Configuration</i>	26	Anyone that needs basic information on the Rockwell Automation software packages that can be used to configure a PowerFlex 750-Series AC Drives with an RD750.

INTRODUCTION TO THE RD750

The RD750

For over twenty years, Rockwell Automation and Advanced Micro Controls Inc. have partnered together to offer the most advanced sensor interface technology on the market. Based on this long standing relationship, AMCI is proud to announce the first and only resolver interface module for the PowerFlex 750-Series AC Drives from Rockwell Automation.

Utilizing advanced resolver to digital conversion technology, the RD750 can interface with a wide variety of resolvers, including those from AMCI, Moog, Reliance, and Tamagawa, as well as many others.

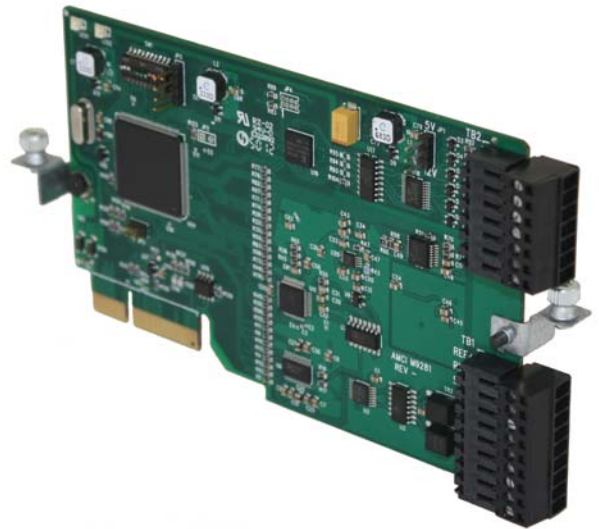

R-D Converter

The heart of the resolver-to-digital converter is a monolithic IC that utilizes a ratiometric, Type II tracking loop converter for high speed data acquisition without velocity induced errors.

To be as accurate as possible, the monolithic R/D converter requires a very specific return voltage from the sine and cosine windings, as well as minimal phase shift between the reference voltage and these return signals. The RD750 has additional hardware to guarantee R/D conversion accuracy.

- **Analog Buffer:** The analog buffer presents a specific load to the resolver. This load prevents the magnetic cores of the resolver from saturating if it is operated at a voltage higher than its published specification. (A resolver can always be operated at a lower voltage without accuracy concerns.)
- **Analog Multiplier:** On power up, or when the RD750 receives a reset signal from the drive, the card reads the sine and cosine return voltages multiple times for approximately sixty milliseconds. With these readings, the RD750 calculates the proper coefficient for an analog multiplier that adjusts the sine and cosine signals so they are optimized for the monolithic R/D converter.
- **Phase Compensator:** The readings that are used to set the analog multiplier are also used by the RD750 to determine the phase shift between the reference voltage and the return signals. Once this value is known, the RD750 generates a second reference signal that is identical in frequency to the first reference, but phase shifted by the proper amount. The first reference voltage signal drives the resolver. The second reference is fed into the R/D converter. To the R/D converter, the reference and return signals appear to be in phase, yielding a more accurate conversion.

The RD750 offers multi-turn position feedback with a single turn position resolution of up to 65,536 counts per turn and a tracking rate of up to 150,000 RPM. In addition to the single resolver interface, the RD750 offers an A/B quadrature output with Z pulse, powered by differential output drivers. These drivers are jumper selectable for 5 or 12 Vdc operation.

The module's basic configuration is accomplished with a bank of ten DIP switches located on the board. The parameters set with these switches are:

- **Transformation Ratio:** Thirteen settings that cover a range of 0.15 to 1.75[†]
- **Reference Frequency:** Fifteen settings from 2.0 to 20.0 kHz
- **Resolver Position Resolution:** Settings of 10, 12, 14, or 16 bits per turn

[†] In order to control the level of the return signals, Transformation Ratio is a more important setting to the RD750 than setting the level of the reference voltage. Setting the TR sets the reference voltage between 3.75 and 15.00 Vrms.

The RD750 (continued)

Encoder Output

In addition to the position, velocity, and status information available over the backplane, the RD750 offers the resolver position data as an incremental quadrature encoder output. The RD750 offers differential $\pm A$, $\pm B$, and $\pm Z$ outputs. The outputs have a factory default output voltage of 5 Vdc, but can be changed to 12 Vdc outputs with a single jumper.

The resolver position resolution also sets the resolution of the encoder output. As shown in the figure below, the encoder outputs make one quadrature state change for every one count change in resolver position. The equipment you attach to the RD750 must be capable of X4 decoding to achieve the same resolution as the resolver position.

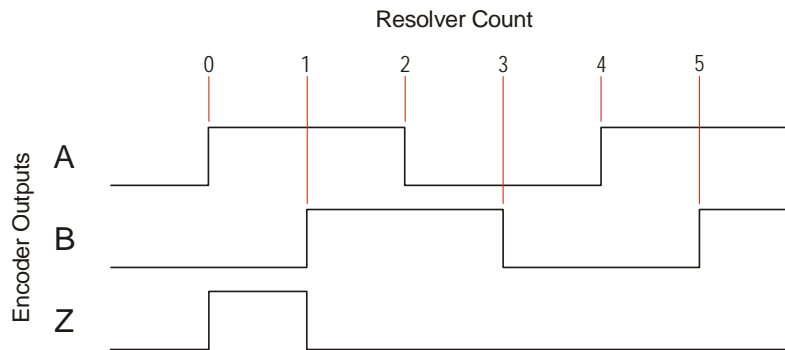

Figure 1 Encoder Output Waveforms

Software Configuration

Software configuration is simplified by closely emulating the Rockwell Automation 20-750-ENC-1 Single Incremental Encoder Option Module. In any Rockwell Automation software that supports the PowerFlex 750-Series Drives, such as RSLogix 5000 or Studio 5000 software, simply select the 20-750-ENC-1 module for the slot that the RD750 is plugged into and position and status information from the RD750 will be transferred to and from the drive.

The 20-750-ENC-1 module supplies captured position data to the drive during homing operations. With the ENC-1 module, homing can be done to the marker (Z) pulse of the encoder or to a discrete input. The RD750 does not have a discrete home input. If you issue a homing command to the drive that uses the marker pulse, the RD750 emulates the result by using the electrical zero position of the resolver. If you issue a homing command to the drive that uses the discrete input, the RD750 will respond, but it will still use the electrical zero position of the resolver.

Introduction to the RD750

The RD750 (continued)

Software Configuration (continued)

Most of the programmable settings on the 20-750-ENC-1 are not applicable to a resolver module. However, the following parameters do affect the operation of the RD750 and must be set correctly.

- **Z Chan Enable:** If this bit is reset to “0”, the RD750 will not generate *Marker Events*, which indicate that the resolver position has passed through electrical zero. If set to “1”, Marker Events are generated. Note that the RD750 always generates Z-pluses on the encoder outputs as well as in the Encoder Status bits reported to the drive.
- **Direction:** Setting this bit reverses the count direction of the resolver. It is *strongly recommended* that you issue a software reset or cycle power to the drive after the count direction is reversed. See additional notes below.
- **Encoder PPR:** Configures the drive for the number of Pulses Per Revolution (encoder lines) emulated by the RD750. This parameter must be set to $(\{\text{Resolver Position Resolution} \times \text{Resolver Speed}\} / 4)$. Resolver Position Resolution is set by the DIP switches on the RD750. Resolver Speed is an inherent property of the resolver and is equal to the number of electrical cycles generated per mechanical rotation of the resolver’s shaft. For example, when using 14 bit position resolution and a 2X speed resolver, the Encoder PPR must be set to $(\{16,384 \times 2\} / 4) = 8,192$.

Other parameters are emulated by the RD750 so it appears to be a 20-750-ENC-1 module to Rockwell Automation software. All ENC-1 parameters, and how the RD750 emulates them, are listed in the [Option Module Parameters](#) section starting on page 22.

Additional Notes on Reversing Count Direction

There are two ways to reverse the count direction when using resolvers. The first is to reverse the connections of the sine winding at the resolver input connector on the RD750. The second method is by setting a parameter bit in the software configuration registers.



Unlike the quadrature encoder, the resolver is an absolute position device. Because of this, using either of the two methods to reverse count direction will result in a change in position value reported to the PowerFlex drive by the RD750. In some cases, this change in position value may cause erratic movement or behavior when the drive is commanded to power a motor. Because of this, it is *strongly recommended* that you issue a software reset or cycle power to the drive after the count direction is reversed.



Do not, under any circumstances, insert or remove the resolver connector or change resolver connections while power is applied to the RD750. Doing so may result in a voltage spike that can damage the reference voltage op-amp.

The RD750 (continued)

Status LED's

As shown in figure 2, two bi-color status LED's on the RD750 offer visual feedback to simplify troubleshooting. LED1 shows the status of the connection to the host drive while LED 2 shows the status of the resolver. Each LED has several blink patterns that are shown in the following figures. Each column in the figure represents one eighth of a second, which means the table shows the LED's state for two seconds. For example, *Host Connection Lost* is indicated by blinking LED1 red at a 1 Hz rate.

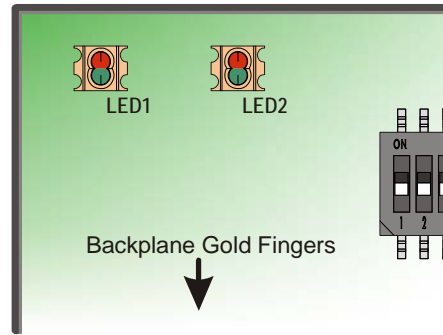

Figure 2 RD750 Status LED's

LED1: Host Drive Connection State

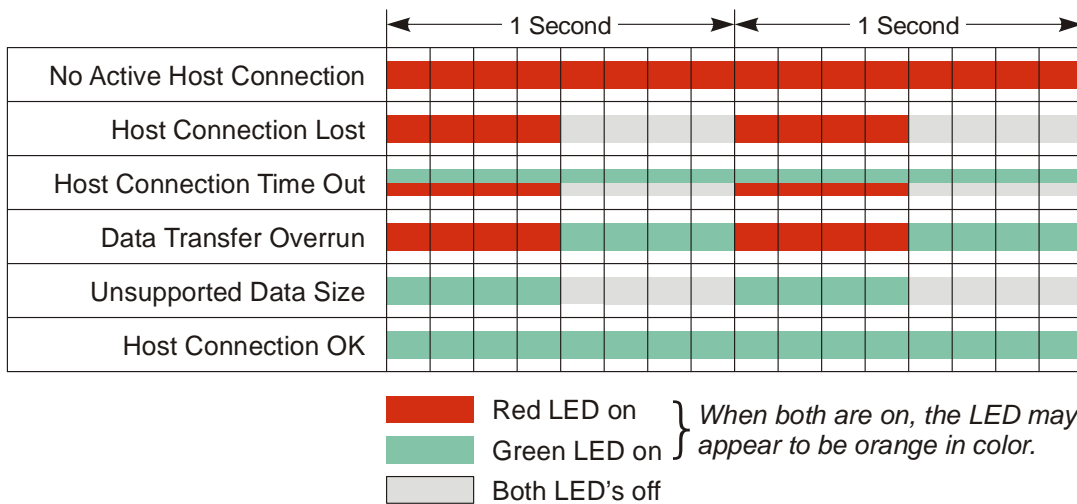

Figure 3 LED1 (Host Connection) Blink Patterns

Errors in communication with the host may occur if the slot the RD750 occupies is not configured as a Rockwell Automation 20-750-ENC-1 Single Incremental Encoder Option Module. Errors may also occur due to environmental conditions such as electrical noise. When an error does occur:

- Verify that the slot is configured as a 20-750-ENC-1 Single Incremental Encoder Option Module in your software
- Issue a drive reset command or cycle power to the drive.

If the error still exists, contact AMCI technical support for additional assistance.

Introduction to the RD750

The RD750 (continued) Status LED's (continued)

LED2: Resolver State

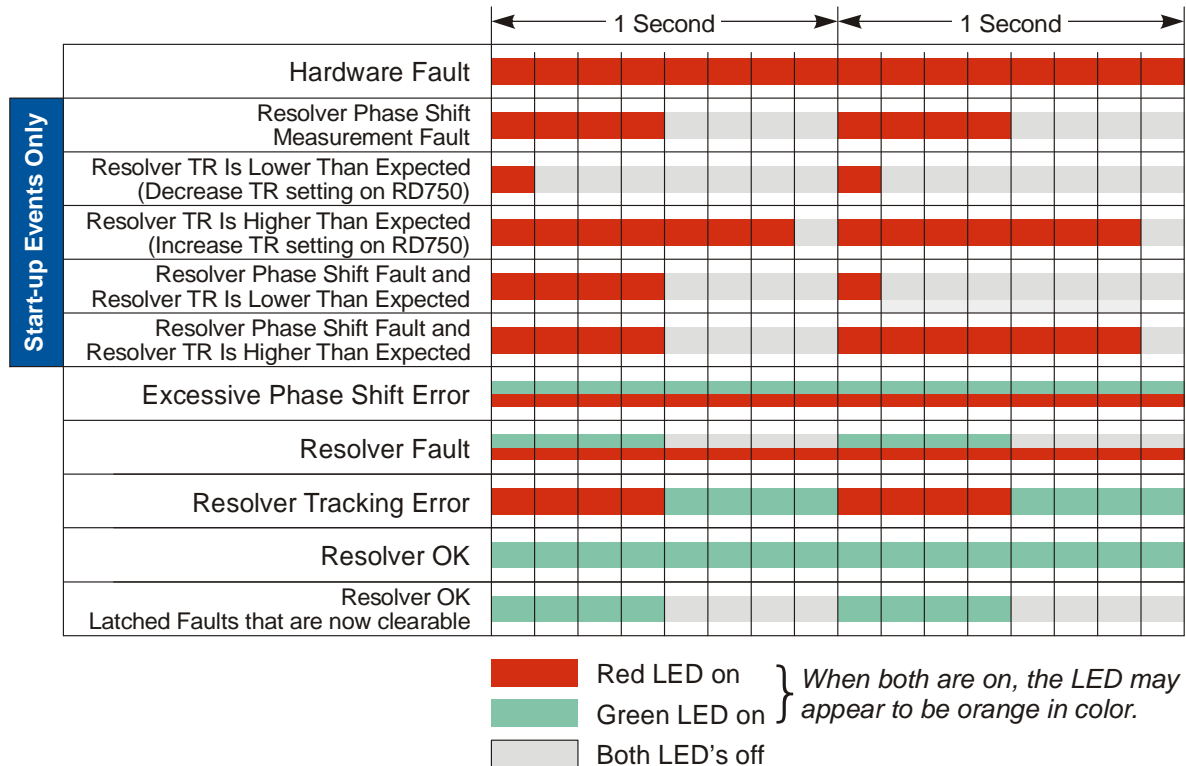

Figure 4 LED2 (Resolver State) Blink Patterns

- The Hardware Fault condition can occur at any time. If it does occur, check over the installation and cabling and reset the card by either issuing a software reset or cycling power to the drive. If the error remains, contact AMCI technical support for further assistance.
- The five red LED blink patterns, *Resolver Phase Shift Measurement Fault* through *Resolver Phase Shift Fault and Resolver TR Is Higher Than Expected*, will only occur when the RD750 is testing the connection to the resolver on power up. If they occur, check your cable type, cable and resolver wiring, and resolver specifications and adjust the DIP switch settings as suggested. DIP switch settings are only read on power up, so you must issue a software reset command or cycle power to the drive before the RD750 will accept the changes.
- Excessive Phase Shift Error should rarely occur, and only if the resolver or cable characteristics change significantly during drive operation. Consider this a warning of an installation issue or a failure of the resolver or RD750.
- Resolver Fault occurs when there is an error with the resolver signals. The RD750 checks the symmetry of the sine and cosine voltages as well as their actual values. A resolver fault is typically caused by cabling issues or improper DIP switch settings on the RD750. In the case of a transient fault, such as electrical noise on the resolver cable, the Resolver Fault condition will clear itself and begin to transmit valid data again. The occurrence of the fault is latched and is shown on this status LED as well as by bits in the backplane data. This bit can be cleared with a Clear Faults command from the drive.
- A Resolver Tracking Error may rarely occur during times of apparent extremely high acceleration. The error is non-fatal and will clear itself once the acceleration rate decreases.

Compatible Sensors

The RD750 is compatible with a broad range of resolvers and variable reluctance transducers including those listed below that are commonly used in VFD and servo systems.

Manufacturer	Model #	Speed	Specified Freq.	Specified TR	Specified Voltage
AMCI	R11X-C10/7	1X	1 kHz	0.45	6.0 Vac
AMCI	R11X-J10/7	1X	5 kHz	0.95	7.0 Vac
Moog / Poly-Scientific	JSSB-21-B-02J	1X	6.6 kHz	1.00	7.5 Vac
Reliance/ Tamagawa	800123-2R/ TS-2014N181E32	1X	2.4 kHz	0.45	26 Vac
Reliance/ Tamagawa	800123-2S/ TS-2014N182E32	2X	2.4 kHz	0.45	26 Vac
Reliance/ Tamagawa	800123-2T/ TS-2014N185E32	5X	2.4 kHz	0.45	26 Vac
Reliance/ Tamagawa	800123-R/ TS-2087N1E9	1X	2.4 kHz	0.45	26 Vac
Reliance/ Tamagawa	800123-S/ TS-2087N2E9	2X	2.4 kHz	0.45	26 Vac
Reliance/ Tamagawa	800123-T/ TS-2087N5E9	5X	2.4 kHz	0.45	26 Vac
Reliance/ Tamagawa	800123-1R/ TS-2087N11E9	1X	2.4 kHz	0.45	26 Vac
Reliance/ Tamagawa	800123-1S/ TS-2087N12E9	2X	2.4 kHz	0.45	26 Vac

Table 1 Common Resolver Sensors

Resolver Transmitters

Resolver transmitters have the rotor as their primary winding. The excitation voltage is applied to the primary and the return signals are read off of the sine/cosine stators. The RD750 is designed to be compatible with all common 1 kHz to 20 kHz resolver transmitters.

Resolver Control Transformers

Resolver control transformers have the stators as their primary windings. Two voltages are applied to the resolver that defines an electrical angle. The rotor output voltage and phase is equal to the difference between the electrical angle supplied through the stators and the mechanical angle of the resolver's shaft.

When using the RD750, it is possible to operate a control transformer "backwards" by applying the signal to the rotor and reading the resulting stator waveforms. You must be aware of the following when using control transformers:

- The operating frequency remains the same.
- The transformation ratio will not be what is stated on the resolver's label or its specifications sheet. Most likely, it won't even be the reciprocal of the specification. If you have an oscilloscope, you can easily measure and calculate the TR, or you can use the RD750 to determine settings that will work for the module.
- Positional accuracy will suffer. The final accuracy will depend on the resolver you use, but 10 bit accuracy or better (≤ 20 min) is typical.
- Repeatability, as opposed to accuracy, will remain extremely high, typically ± 1 count regardless of your resolution setting.

Introduction to the RD750

Compatible Sensors (continued)

Single and Multi-Speed Resolvers

The most common resolver is known as a *single speed* resolver. It is manufactured in such a way that one turn of the resolver's shaft produces one sinusoidal cycle on the sine and cosine output windings. *Multi-speed* resolvers are wound with additional poles so that one rotation of the resolver's shaft produces multiple sinusoidal cycles on the outputs. This is important in three ways in RD750 applications:

- ▶ **Z-Pulse Output:** The RD750 Encoder Output emulates the electrical cycles of the resolver. For example, if a 5-speed resolver is used, the RD750 will output five Z-pulses for every mechanical rotation of the resolver's shaft.
- ▶ **Maximum Position Resolution:** The RD750 emulates the 20-750-ENC-1 option module in Rockwell Automation software. The ENC-1 module has a resolution limit of 80,000 counts per turn. If this value is exceeded, velocity data and motor commutation angle calculations will be incorrect.
- ▶ **Resolver Tracking Speed:** As explained in the following section, Resolver Tracking Speed is the maximum rotational speed at which the resolver position can still be accurately decoded. This refers to the rate at which the sinusoidal outputs change, which is the mechanical rotational rate of the resolver's shaft multiplied by the resolver's speed. For example, a 5X speed resolver whose shaft is rotating at a rate of 2,000 RPM will have an apparent rotational rate of 10,000 RPM (2,000 RPM x 5).

Resolver Tracking Speed

Resolver Tracking Speed is the maximum rotational speed at which the resolver position can still be accurately decoded. Exceeding these speeds can affect positional accuracy. Resolver Tracking Speed is based on the operating frequency and desired position resolution.

Operating Frequency		Position Resolution	Resolver Tracking Speed (Single speed resolver)
2.0 to 2.5 kHz	OR	16 bit ^①	7,500 RPM
3.0 to 5.0 kHz	OR	14 bit ^②	30,000 RPM
6.0 to 8.0 kHz	OR	12 bit ^③	60,000 RPM
10.0 to 20.0 kHz	OR	10 bit ^③	150,000 RPM

①: Maximum operating frequency for 16 bit resolution is 10 kHz

②: Maximum operating frequency for 14 bit resolution is 12 kHz

③: Maximum operating frequency for 12 and 10 bit resolutions is 20 kHz

Table 2 Resolver Tracking Speeds

A resolver tracking error may be reported by the RD750 during times of apparent extremely high acceleration. The error is rare, non-fatal, and will clear itself once the acceleration rate decreases. The Resolver Tracking Speed refers to the rate at which the sinusoidal outputs are changing. For single speed resolvers, this is equal to the rotational rate of the resolver's shaft. For multi-speed resolvers, this is equal to the rotational rate of the resolver's shaft multiplied by the speed of the resolver.

SPECIFICATIONS

Sensor Type

Resolver Transmitters and similar sensors with sine/cosine stator outputs such as variable reluctance transducers.

Number of Resolver Input Channels

One

Installation Locations

Slots 4 or 5 of the PowerFlex 750 backplane

Weight

0.167 lbs. (0.076 kg.) with mating connectors

Input Power

All power is drawn from the 750-Series backplane

Current Draw

+12 Vdc: 145 mA without sensor
170 mA with AMCI R11X-J resolver
240 mA with reference shorted by 5 Ω (Fault Condition)

-12 Vdc: 60 mA without sensor
90 mA with AMCI R11X-J resolver
160 mA with reference shorted by 5 Ω (Fault Condition)

+24 Vdc: 10 mA with no load on encoder outputs

Measurement Method

Ratiometric. Compensates for and eliminates most sources of error, including phase shift, voltage drift, electrical noise, and temperature changes.

Maximum Cable Length

1000 ft. with proper cable and installation
Belden 9730 recommended for lengths < 100 ft.
Belden 9730 recommended for lengths > 100 ft.

Reference Output Frequency

Programmable from 2 kHz to 20 kHz
Factory Default of 2.5 kHz

Sensor Transformation Ratio

Programmable from 0.15 to 1.75
Factory Default of 0.45

Reference Output Voltage

Set by Sensor Transformation Ratio Setting.
Programmable from 3.75 to 15.0 Vrms
Factory Default of 10.30 Vrms

Reference Output Current

50 mArms maximum

Resolver Position Resolution

10, 12, 14, or 16 bits per turn. (1,024, 4,096, 16,384 or 65,536 steps over a single turn)^①
Factory Default of 14 bits per turn

Encoder Resolution

Set by Resolver Position Resolution setting

Encoder Output Type

Differential. Jumper selectable to 5 or 12 Vdc

Encoder Output Current

25 mA per channel

Environmental Specifications

Ambient Operating Temperature
..... 0° to 50° C (32° to 122° F)

Storage Temperature
..... -40° to 70° C (-40° to 158° F)

Product designed for operation in EN 61800-5-1
Pollution Degree 1 and 2 environments

Status LED's

See *Status LED's* starting on page 10

Connectors

Mating connectors are included with the RD750 and are available separately under the following AMCI part numbers

Connector	AMCI Part #	Wire	Strip Length	Max. Tightening Torque	Weidmueller #
Resolver	MW-9	28 - 14 AWG	0.236" (6 mm)	2.21 lb-in (0.25 Nm)	1615710000
Encoder	MW-7	28 - 14 AWG	0.236" (6 mm)	2.21 lb-in (0.25 Nm)	1610190000

① Assuming a single-speed resolver. Multi-speed resolvers will produce these counts over a single electrical cycle of the resolver's outputs. Care in programming must be exercised to ensure the total number of counts per mechanical rotation do not exceed 80,000 counts.

INSTALLING THE RD750

Setting Encoder Jumper and DIP Switches

RD750 Orientation

Figure 5 shows you how the card must be oriented before using the rest of this section to set the encoder jumper and the bank of DIP switches that configure the resolve interface. The figure also shows the location of the jumper and the bank of DIP switches.

In this orientation, the white silkscreen writing on the RD750 is upside down. However, this orientation makes the DIP switches follow a binary pattern, and this is the orientation that the RD750 will have once it is installed in the drive.

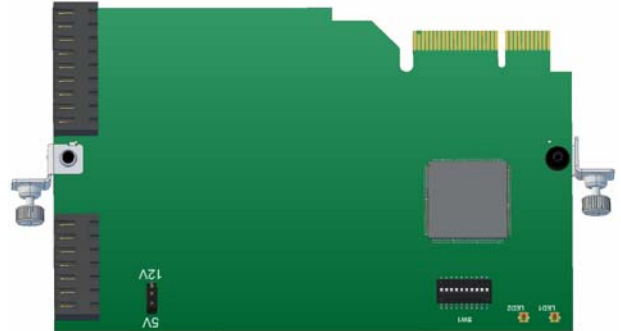

Figure 5 RD750 Orientation

Setting the Encoder Jumper

The encoder jumper selects the output voltage of the encoder signals generated by the RD750. The two choices are 5 Vdc or 12 Vdc outputs. Figure 6 is a close up of the Encoder Jumper. This image shows the two pin jumper on the pins that select the 5 Vdc outputs. This setting is the factory default. To make the encoder outputs operate at 12 Vdc, move the two pin header to the “12V” and center pins.

CAUTION

Verify the input voltage range of any equipment you attach to the encoder outputs. Operating the encoder outputs at 12 Vdc can potentially damage equipment that is designed for a 5 Vdc signal.

NOTE

If the jumper is missing, the encoder outputs will operate at 5 Vdc.

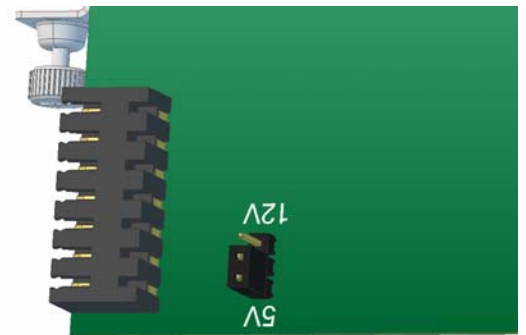

Figure 6 Encoder Output Voltage Jumper

Setting Encoder Jumper and DIP Switches (continued)

DIP Switch Settings

Figure 7 below shows the DIP Switch settings for selecting the resolver and encoder resolution, the reference frequency, and the resolver’s transformation ratio.

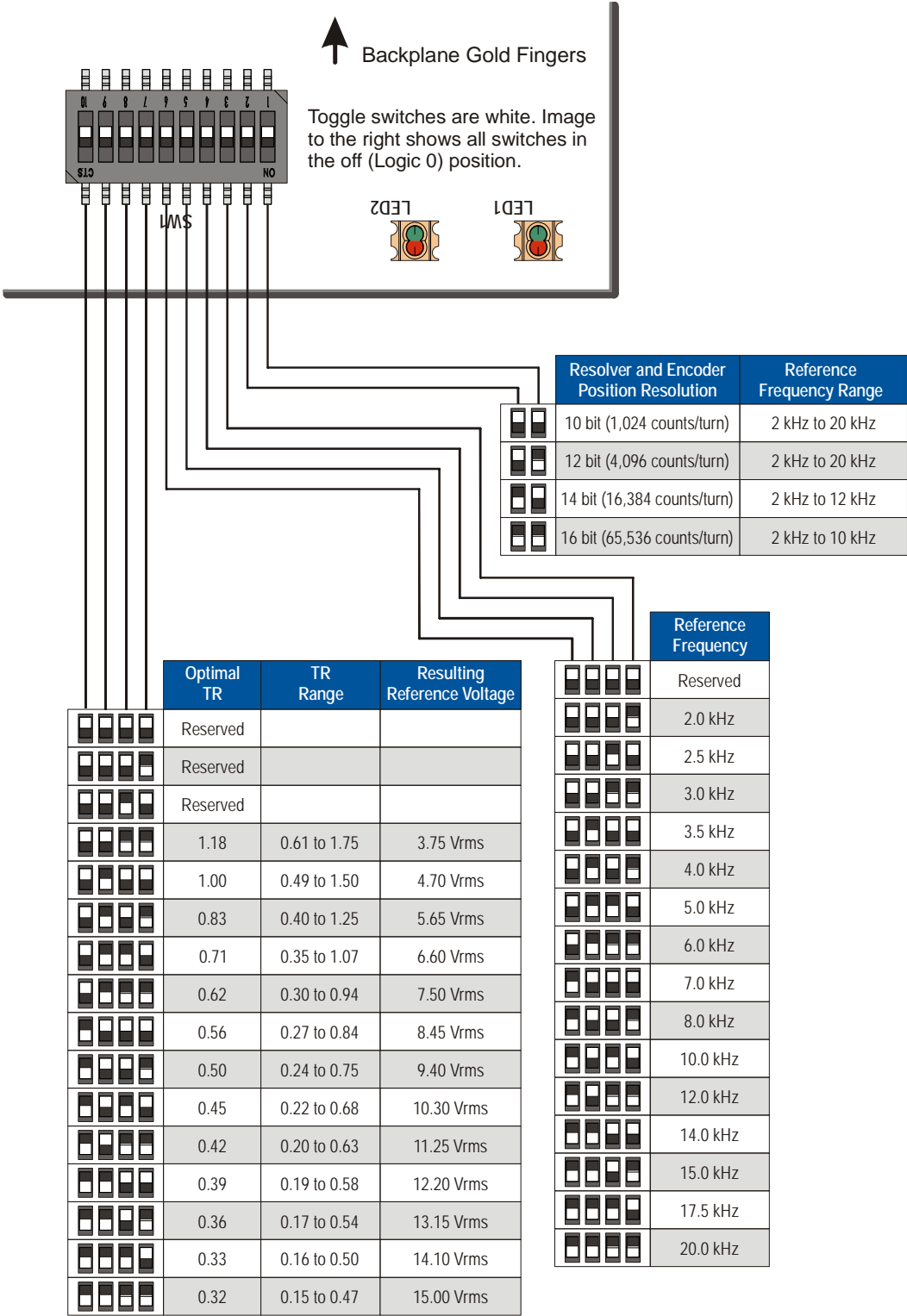

Figure 7 DIP Switch Settings

Installing the RD750

Setting Encoder Jumper and DIP Switches (continued)

Settings for Common Resolvers

						RD750 Suggested Settings		
Manufacturer	Model #	Speed	Specified Freq.	Specified TR	Specified Voltage	Reference Frequency	TR Setting	Maximum Resolution (bits) ^①
AMCI	R11X-C10/7	1X	1 kHz	0.45	6.0 Vac	2 kHz	0.45	16
AMCI	R11X-J10/7	1X	5 kHz	0.95	7.0 Vac	5 kHz	1.00	16
Moog / Poly-Scientific	JSSB-21-B-02J	1X	6.6 kHz	1.00	7.5 Vac	7 kHz	1.00	16
Reliance/Tamagawa	800123-2R/ TS-2014N181E32	1X	2.4 kHz	0.45	26 Vac	2.5 kHz	0.45	16
Reliance/Tamagawa	800123-2S/ TS-2014N182E32	2X	2.4 kHz	0.45	26 Vac	3.0 kHz ^②	0.45	14
Reliance/Tamagawa	800123-2T/ TS-2014N185E32	5X	2.4 kHz	0.45	26 Vac	3.0 kHz ^③	0.45	12
Reliance/Tamagawa	800123-R/ TS-2087N1E9	1X	2.4 kHz	0.45	26 Vac	2.5 kHz	0.45	16
Reliance/Tamagawa	800123-S/ TS-2087N2E9	2X	2.4 kHz	0.45	26 Vac	3.0 kHz ^②	0.45	14
Reliance/Tamagawa	800123-T/ TS-2087N5E9	5X	2.4 kHz	0.45	26 Vac	3.0 kHz ^③	0.45	12
Reliance/Tamagawa	800123-1R/ TS-2087N11E9	1X	2.4 kHz	0.45	26 Vac	2.5 kHz	0.45	16
Reliance/Tamagawa	800123-1S/ TS-2087N12E9	2X	2.4 kHz	0.45	26 Vac	3.0 kHz ^②	0.45	14

① Maximum Resolution is based on the 20-750-ENC-1 limit of 80,000 counts per turn. Exceeding this value will cause errors in velocity feedback and the motor commutation angle calculations. Total counts from a resolver equals the resolution multiplied by the speed of the resolver. For 2X resolvers, the maximum total count is $2^{14} \times 2 = 32,768$. For 5X resolvers, the maximum total count is $2^{12} \times 5 = 20,480$.

② Operating at 3.0 kHz instead of 2.5 kHz increases the Resolver Tracking Speed from 3,750 RPM to 15,000 RPM for 2X speed resolvers. See [Resolver Tracking Speed](#) on page 13 for more information.

③ Operating at 3.0 kHz instead of 2.5 kHz increases the Resolver Tracking Speed from 1,500 RPM to 6,000 RPM for 5X speed resolvers. See [Resolver Tracking Speed](#) on page 13 for more information.

Table 3 Suggested Settings for Common Resolvers

Determining Settings for Other Resolvers

Frequency Setting

For most applications, simply determine your resolver's rated operating frequency and choose the closest available setting on the RD750. This includes using the 2 kHz setting for any resolver that has an operating frequency rating of 1 kHz to 2 kHz. (The RD750 is not compatible with 400 Hz resolvers.) Generally speaking, a $\pm 20\%$ shift in operating frequency will have a negligible effect on the resolver's outputs.

Setting Encoder Jumper and DIP Switches (continued)

Determining Settings for Other Resolvers (continued)

TR Setting for Transmitter Resolvers

Referring back to figure 7, *DIP Switch Settings* on page 16, the “Optimal TR” column is the median value of the range listed in the “TR Range” column. If your resolver’s TR falls within the listed range, the setting will work with the RD750. For example, if your resolver has a TR of 0.45, any “Optimal TR” setting in the table from 0.83 to 0.32 will work, but the setting that is optimized for 0.45 gives the RD750 the widest range of adjustment to compensate for variations in the resolver’s TR.

Note that the TR setting also sets the value of the RD750’s reference voltage. Operating a resolver at a voltage below its specified value *never* affects the accuracy of the resolver. Operating a resolver at a voltage above its specified value *rarely* affects the accuracy of the resolver and this only occurs if the input power saturates the cores of the resolver. The RD750’s Analog Buffer minimizes the risk of this happening when you operate the resolver above its specified reference voltage. If you have concerns about operating your resolver at a higher reference voltage, you can choose your TR setting based on the reference voltage. However, the TR of your resolver must fall within the TR Range listed for that reference voltage.

TR Setting for Control Transformer Resolvers

Determining the TR setting for a control transformer resolver requires powering the system and either measuring the resolver signals or using the resolver status LED as feedback. For now, set the TR DIP switches to a value of 0.5. The procedure for setting the TR of a control transformer resolver is presented at the end of this chapter in the *Determining the TR Setting of a Control Transformer Resolver* section starting on page 21.

Installing the RD750

Installing the RD750

Installation of the RD750 follows the same procedure shared by all Allen-Bradley option modules:

- 1) Firmly press the module edge connector into the desired port. Note that the RD750 can only be installed in ports 4 or 5.
- 2) Tighten the top and bottom retaining screws.
 - Recommended torque = 4.0 lb•in (0.45 N•m)
 - Recommended screwdriver = T15 Hexalobular
 - **Important:** Do not over-tighten retaining screws.

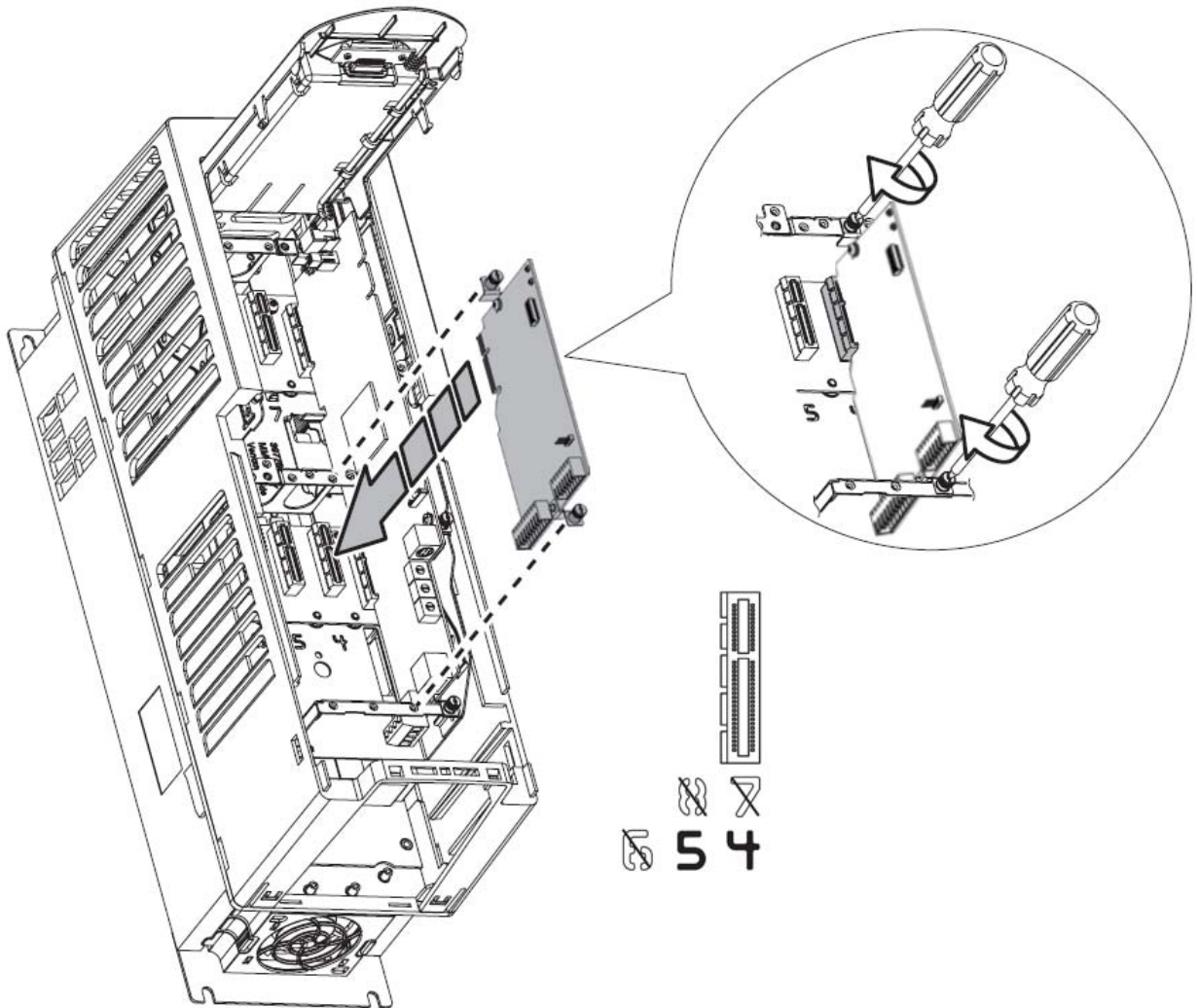

Figure 8 Installing the RD750

Wiring the Resolver Input



Do not, under any circumstances, insert or remove the resolver connector or change resolver connections while power is applied to the RD750. Doing so may result in a voltage spike that can damage the reference voltage op-amp.

When wiring the resolver to the RD750, cabling suggestions from your resolver’s manufacturer should be followed with the possible exception of grounding the cable shield at the resolver. The RD750 connects the shields of the cable to the chassis of the PowerFlex drive, and grounding the cable shields at the resolver or at any cable junction can lead to ground loops that may affect system performance.

If your resolver’s manufacturer does not recommend an extension cable, AMCI suggests Belden 9873 for cable lengths less than 100 feet, or Belden 9730 for any length. These cables are low capacitance cables with three individually shielded twisted pairs. They have been used in thousands of AMCI installations without issue. Figure 9 below shows how to wire the Belden 9873 or 9730 cable to the resolver input connector on the RD750.

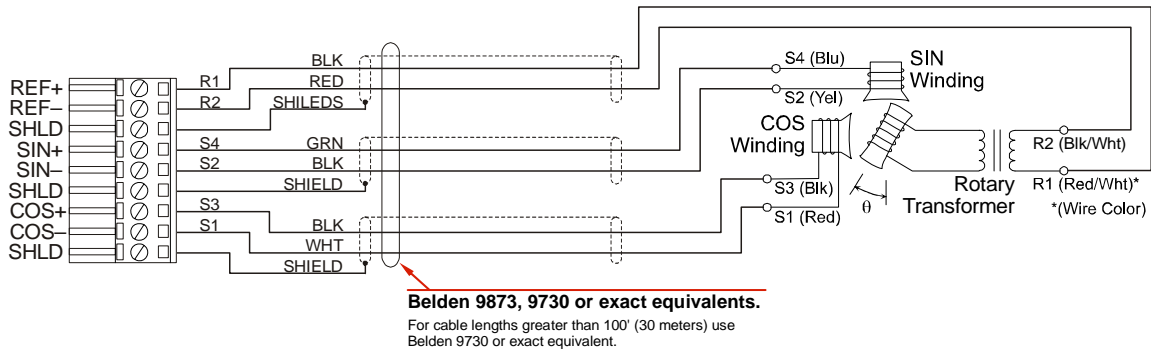

Belden 9873, 9730 or exact equivalents. For cable lengths greater than 100' (30 meters) use Belden 9730 or exact equivalent.

Figure 9 Resolver Input Wiring

Reversing Count Direction

There are two ways to reverse count direction. One option is with the “Direction” configuration data bit. The other is by reversing the ±SIN (S2-S4) connections on the resolver input connector. In figure 9 above, you would reverse the connections of the WHT/BLK pair.

Encoder Output Wiring

Figure 8 below shows the suggested wiring from the encoder output connector of the RD750 to your equipment. Belden 9873 and 9730 are the same cables suggested for use as the resolver extension cables. Alpha 6053C and 6317 are the three pair versions of the cables suggested by Rockwell Automation for use with their incremental encoders.

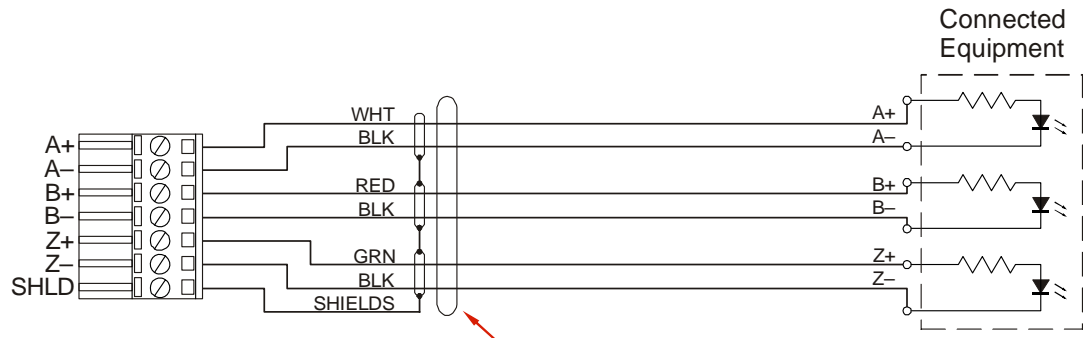

Belden 9873, Alpha 6053C or exact equivalents. For cable lengths greater than 100' (30 meters) use Belden 9730, Alpha 6317 or exact equivalents.

Figure 10 Encoder Output Wiring

Installing the RD750

Encoder Output Wiring (continued)



The RD750 can output 5 Vdc or 12 Vdc differential signals. *Setting the Encoder Jumper*, which is found on page 15, shows the location of the jumper used to set the output voltage. Verify the input voltage range of any equipment you attach to the encoder outputs. Operating the encoder outputs at 12 Vdc can potentially damage equipment that is designed for a 5 Vdc signal.

Determining the TR Setting of a Control Transformer Resolver

Once the drive is powered, the RD750 may require configuration changes to work properly with a control transformer resolver. A true RMS voltmeter or oscilloscope will simplify the process, but the Resolver Status LED can also be used to make the changes.

With a True RMS Meter or Scope

- 1) Measure and record the voltage across the \pm REF (R1-R2) connections on the resolver input connector.
 - 2) Measure and record the voltage across the \pm SIN (S2-S4) connections. If possible, rotate the resolver until this voltage is at its minimum, which should be in the millivolt range.
 - 3) Measure and record the voltage across the \pm COS (S1-S3) connections.
- ▶ *If you were able to rotate the resolver until the \pm SIN voltage was at its minimum, the effective TR for your control transformer is \pm COS voltage / \pm REF voltage.*
 - ▶ *If you were not able to rotate the resolver, the effective TR for your control transformer is:*

$$TR = \left(\sqrt{(\pm \text{SIN voltage})^2 + (\pm \text{COS voltage})^2} \right) / \pm \text{REF Voltage}$$

Refer back to the *DIP Switch Settings* section on page 16 and set your DIP switch settings to the closest optimal TR setting that you can. Cycle power to the drive or issue a software reset command to re-initialize the RD750. At this point, the LED2 Status LED should be on and green. If this is not the case, refer back to figure 4, *LED2 (Resolver State) Blink Patterns* on page 11 for additional information on the state of the resolver connection.

With the Resolver Status LED (LED2)

If you followed the instructions for initial setup, you set the TR DIP switch settings to a value of 0.50. When you apply power to the drive, LED2 on the RD750 will most likely be in one of three states:

- ▶ On Green: Resolver is being read successfully
- ▶ Blinking Red with a short “on” time: Resolver TR is lower than expected, decrease the DIP switch setting.
- ▶ Blinking Red with a long “on” time: Resolver TR is higher than expected, increase the DIP switch setting.
- ▶

In order to set the TR, you will have to:

- 1) Manually change the DIP switch settings either up or down depending on the state of LED2.
- 2) Cycle power to the drive or issue a software reset command to force the RD750 to read the state of the DIP switches
- 3) Check the new state of LED2 and continue these steps until you find the proper setting.

Ideally, you will find the entire range of settings where the resolver can be read successfully and set the TR setting to the center of this range.

OPTION MODULE PARAMETERS

Parameter List

The RD750 closely emulates the Single Incremental Encoder Option Module from Rockwell Automation. The eight parameters that are available on the 20-750-ENC-1 are also available on the RD750.

NOTE The parameter and bit names are defined for the 20-750-ENC-1 and these names will appear in your project. Please note that some of these bits are not used by the RD750 and the meaning of others has been altered.

NOTE Phase Loss Count (P7) and Quad Loss Count (P8) parameters are not counters on the RD750. They are bit fields that show resolver errors. The names of these bits are defined by AMCI and can be added to your RSLogix 5000 or Studio 5000 project by using User Defined Tags.

File	Group	No.	Display Name Full Name Description	Values	Read-Write	Data Type																																																			
RD750 Resolver Feedback Option Module		1	Encoder Cfg Encoder Configure Configures the count direction and active encoder channels Options <table border="1" style="margin-left: 20px;"> <thead> <tr> <th></th> <th>Reserved</th> <th>Reserved</th> <th>Reserved</th> <th>Reserved</th> <th>Reserved</th> <th>Reserved</th> <th>Reserved</th> <th>Reserved</th> <th>Reserved</th> <th>Reserved</th> <th>Direction</th> <th>Single Ended</th> <th>Inv Home In</th> <th>Edge Mode</th> <th>A Chan Only</th> <th>Z Chan Enbl</th> </tr> </thead> <tbody> <tr> <td>Default</td> <td>0</td> <td>0</td> <td>0</td> <td>0</td> <td>0</td> <td>0</td> <td>0</td> <td>0</td> <td>0</td> <td>0</td> <td>0</td> <td>0</td> <td>0</td> <td>0</td> <td>0</td> <td>0</td> </tr> <tr> <td>Bit</td> <td>15</td> <td>14</td> <td>13</td> <td>12</td> <td>11</td> <td>10</td> <td>9</td> <td>8</td> <td>7</td> <td>6</td> <td>5</td> <td>4</td> <td>3</td> <td>2</td> <td>1</td> <td>0</td> </tr> </tbody> </table> <p>Bit 0: "Z Chan Enable" - If this bit is reset to "0", the RD750 will not generate Marker Events, which indicate that the resolver position has passed through electrical zero. If set to "1", Marker Events are generated. Marker Events are indicated by bit 8 of the Encoder Status word (P5.8) Note that the RD750 always generates Z-pluses on the encoder outputs as well as in the Encoder Status bits reported to the drive.</p> <p>Bit 1: "A Chan Only" - Not used by the RD750, but the state of this bit affects the operation of the PowerFlex drive. It is strongly suggested that this bit always be reset to "0". If this bit is set to "1", the drive will ignore errors reported in the "Quad Loss Count" register (P8) and the number of counts per turn generated by the RD750 must be set to less than or equal to 20,000 instead of 80,000.</p> <p>Bit 2: "Edge Mode" - When this bit is reset to "0", the PowerFlex drive uses an accumulated count to determine the speed of the motor. When this bit is set to "1", the PowerFlex drive calculates speed based on the time between changes in resolver position.</p> <p>Bit 3: "Inv Home In" - Not used by the RD750.</p> <p>Bit 4: "Single Ended" - Not used by the RD750, but the state of this bit affects the operation of the PowerFlex drive. It is strongly suggested that this bit always be reset to "0". If this bit is set to "1" the PowerFlex drive will ignore errors reported in the "Phase Loss Count" register (P7).</p> <p>Bit 5: "Direction" - Used to reverse the direction of rotation needed to produce an increase in position counts. It is also possible to reverse count direction by reversing the S2-S4 connection at the resolver input connector. When the resolver is connected as shown in Figure 9, Resolver Input Wiring, resetting this bit to "0" results in clockwise increasing counts when looking at the resolver shaft. Setting this bit to "1" results in counter-clockwise increasing counts.</p> <p>Using either of the two methods to reverse count direction will result in a change in position value reported to the PowerFlex drive by the RD750. In some cases, this change in position value may cause erratic movement or behavior when the drive is commanded to power a motor. Because of this, it is strongly recommended that you issue a software reset or cycle power to the drive after the count direction is reversed.</p>		Reserved	Reserved	Reserved	Reserved	Reserved	Reserved	Reserved	Reserved	Reserved	Reserved	Direction	Single Ended	Inv Home In	Edge Mode	A Chan Only	Z Chan Enbl	Default	0	0	0	0	0	0	0	0	0	0	0	0	0	0	0	0	Bit	15	14	13	12	11	10	9	8	7	6	5	4	3	2	1	0		RW	16-bit integer
			Reserved	Reserved	Reserved	Reserved	Reserved	Reserved	Reserved	Reserved	Reserved	Reserved	Direction	Single Ended	Inv Home In	Edge Mode	A Chan Only	Z Chan Enbl																																							
		Default	0	0	0	0	0	0	0	0	0	0	0	0	0	0	0	0																																							
Bit	15	14	13	12	11	10	9	8	7	6	5	4	3	2	1	0																																									
2	Encoder PPR Encoder Pulses Per Revolution Configures the drive for the number of Pulses Per Revolution (encoder lines) emulated by the RD750. This parameter must be set to $\{\text{Resolver Position Resolution} \times \text{Resolver Speed}\} / 4$. Resolver Position Resolution is set by the DIP switches on the RD750. Resolver Speed is an inherent property of the resolver. For example, when using 14 bit position resolution and a 2X speed resolver, the Encoder PPR must be set to: $\{16,384 \times 2\} / 4 = 8,192$.	Default: 1024 Min/Max: 2 / 20000	RW	Real																																																					
3	Fdbk Loss Cfg Feedback Loss Configure Configures how the drive reacts to an error status condition for the feedback. "Ignore" (0) - No action taken "Alarm" (1) - Type 1 alarm indicated "Flt Minor" (2) - Minor fault indicated. If running, drive continues to run. Enable with P950 [Minor Flt Cfg]. If not enabled, acts like a major fault. "FltCoastStop" (3) - Major fault indicated. Coast to Stop.	Default: 3 = "FltCoastStop" Min/Max: 0 = "Ignore" 1 = "Alarm" 2 = "Flt Minor" 3 = "FltCoastStop"	RW	Real																																																					

(continued next page)

Option Module Parameters

Parameter List (continued)

File	Group	No.	Display Name Full Name Description	Values	Read-Write	Data Type																																																		
RD750 Resolver Feedback Option Module		4	Encoder Feedback Encoder Feedback Displays the position feedback value of the resolver. This can be used as a source for the main control (Port 0) Feedback Select. See Note Below.	Default: 0 Min/Max: ±2,147,483,647	RO	Real																																																		
		5	Encoder Status Encoder Status Status Information from the RD750. Options <table border="1" style="width: 100%; border-collapse: collapse;"> <thead> <tr> <th></th> <th>Direction</th> <th>HomMrk Event</th> <th>HomMrk Armed</th> <th>HomeIn Event</th> <th>HomeIn Armed</th> <th>Home Input</th> <th>Inv Home In</th> <th>Marker Event</th> <th>Z Not Input</th> <th>Z Input</th> <th>B Not Input</th> <th>B Input</th> <th>A Not Input</th> <th>A Input</th> <th>A Chan Only</th> <th>Z Chan Enbl</th> </tr> </thead> <tbody> <tr> <td>Default</td> <td>0</td> <td>0</td> <td>0</td> <td>0</td> <td>0</td> <td>0</td> <td>0</td> <td>0</td> <td>0</td> <td>0</td> <td>0</td> <td>0</td> <td>0</td> <td>0</td> <td>0</td> <td>0</td> </tr> <tr> <td>Bit</td> <td>15</td> <td>14</td> <td>13</td> <td>12</td> <td>11</td> <td>10</td> <td>9</td> <td>8</td> <td>7</td> <td>6</td> <td>5</td> <td>4</td> <td>3</td> <td>2</td> <td>1</td> <td>0</td> </tr> </tbody> </table> Bit 0: "Z Chan Enable" - State of the corresponding bit in the [Encoder Cfg] parameter. Bit 1: "A Chan Only" - State of the corresponding bit in the [Encoder Cfg] parameter. Bit 2: "A Input" - Emulated signal based on the present position reported by the RD750 in the Encoder Feedback parameter (P4). Bit 3: "A Not Input" - Emulated signal based on the present position reported by the RD750 in the Encoder Feedback parameter (P4). Bit 4: "B Input" - Emulated signal based on the present position reported by the RD750 in the Encoder Feedback parameter (P4). Bit 5: "B Not Input" - Emulated signal based on the present position reported by the RD750 in the Encoder Feedback parameter (P4). Bit 6: "Z Input" - Emulated signal based on the present position reported by the RD750 in the Encoder Feedback parameter (P4). Bit 7: "Z Not Input" - Emulated signal based on the present position reported by the RD750 in the Encoder Feedback parameter (P4). Bit 8: "Marker Event" - When channel Z is enabled, this bit indicates that the resolver position has passed through zero. For single speed resolvers, this occurs once per rotation. For multi-speed resolvers, this occurs once for every electrical cycle of the resolver. This bit will remain on until cleared by a clear fault command. Bit 9: "Inv Home In" - State of the corresponding bit in the [Encoder Cfg] parameter. Not used by the RD750. Bit 10: "Home Input" - A Home Input is not available on the RD750. This bit is always "0" Bit 11: "HomeIn Armed" - Indicates that the homing logic of the drive is configured to latch the resolver position on the next transition of the home input. The RD750 does not have a discrete input and will respond by capturing the resolver position at the next electrical zero position of the resolver. Bit 12: "HomeIn Event" - Normally "0". Set to "1" in response to a "HomeIn Armed" event after the resolver position passes through an electrical zero position. Reset with a Clear Errors command from the drive. Bit 13: "HomMrk Armed" - Indicates that the homing logic of the drive is configured to latch the resolver position on the next marker (Z) pulse. The RD750 will respond by capturing the resolver position at the next electrical zero position of the resolver. Bit 14: "HomMrk Event" - Normally "0". Set to "1" in response to a "HomMrk Armed" event after the resolver position passes through an electrical zero position. Reset with a Clear Errors command from the drive. Bit 15: "Direction" - State of the corresponding bit in the [Encoder Cfg] parameter.		Direction	HomMrk Event	HomMrk Armed	HomeIn Event	HomeIn Armed	Home Input	Inv Home In	Marker Event	Z Not Input	Z Input	B Not Input	B Input	A Not Input	A Input	A Chan Only	Z Chan Enbl	Default	0	0	0	0	0	0	0	0	0	0	0	0	0	0	0	0	Bit	15	14	13	12	11	10	9	8	7	6	5	4	3	2	1	0	RO	16-bit integer
			Direction	HomMrk Event	HomMrk Armed	HomeIn Event	HomeIn Armed	Home Input	Inv Home In	Marker Event	Z Not Input	Z Input	B Not Input	B Input	A Not Input	A Input	A Chan Only	Z Chan Enbl																																						
Default	0	0	0	0	0	0	0	0	0	0	0	0	0	0	0	0																																								
Bit	15	14	13	12	11	10	9	8	7	6	5	4	3	2	1	0																																								
6	Error Status Error Status Status Information that will result in a feedback loss condition. Options <table border="1" style="width: 100%; border-collapse: collapse;"> <thead> <tr> <th></th> <th>SI Comm Loss</th> <th>Reserved</th> <th>Reserved</th> <th>Reserved</th> <th>Reserved</th> <th>Reserved</th> <th>Reserved</th> <th>Reserved</th> <th>Reserved</th> <th>Reserved</th> <th>Reserved</th> <th>Reserved</th> <th>Reserved</th> <th>Quad Loss</th> <th>Phase Loss</th> <th>Open Wire</th> </tr> </thead> <tbody> <tr> <td>Default</td> <td>0</td> <td>0</td> <td>0</td> <td>0</td> <td>0</td> <td>0</td> <td>0</td> <td>0</td> <td>0</td> <td>0</td> <td>0</td> <td>0</td> <td>0</td> <td>0</td> <td>0</td> <td>0</td> </tr> <tr> <td>Bit</td> <td>15</td> <td>14</td> <td>13</td> <td>12</td> <td>11</td> <td>10</td> <td>9</td> <td>8</td> <td>7</td> <td>6</td> <td>5</td> <td>4</td> <td>3</td> <td>2</td> <td>1</td> <td>0</td> </tr> </tbody> </table> Bit 0: "Open Wire" - Set when an error in the resolver signals prevents a valid position measurement from being made. Bit 1: "Phase Loss" - Set by drive in response to error bits in the Phase Loss Count parameter (P7). Bit 2: "Quad Loss" - Set by drive in response to error bits in the Quad Loss Count parameter (P8). Bit 15: "SI Comm Loss" - Indicates a communication loss between the main control board and the RD750 over the Serial Interface backplane.		SI Comm Loss	Reserved	Reserved	Reserved	Reserved	Reserved	Reserved	Reserved	Reserved	Reserved	Reserved	Reserved	Reserved	Quad Loss	Phase Loss	Open Wire	Default	0	0	0	0	0	0	0	0	0	0	0	0	0	0	0	0	Bit	15	14	13	12	11	10	9	8	7	6	5	4	3	2	1	0	RO	16-bit integer		
	SI Comm Loss	Reserved	Reserved	Reserved	Reserved	Reserved	Reserved	Reserved	Reserved	Reserved	Reserved	Reserved	Reserved	Quad Loss	Phase Loss	Open Wire																																								
Default	0	0	0	0	0	0	0	0	0	0	0	0	0	0	0	0																																								
Bit	15	14	13	12	11	10	9	8	7	6	5	4	3	2	1	0																																								

(continued on next page)



The RD750 uses the Phase Loss Count (P7) and Quad Loss Count (P8) parameters as status bits when there is a latched fault or temporary error with the position value. These bits must be monitored to assure proper feedback. The RD750 does not reset or freeze the Encoder Feedback value when an error occurs.

Parameter List (continued)

File	Group	No.	Display Name Full Name Description	Values	Read-Write	Data Type																																																																				
RD750 Resolver Feedback Option Module		7	<p>Phase Loss Count Phase Loss Count</p> <p>Resolver Status Information from the RD750.</p> <p>In the 20-750-ENC-1 module for Rockwell Automation, this parameter stores the number of times a phase loss error occurs within a one millisecond sample interval. There is no equivalent error in a resolver interface, so the RD750 uses this parameter to transmit resolver status information. Depending on which bits are set, this parameter value will be between 0 and 127.</p> <p>NOTE: The following bit names are designations from AMCI. They will not appear in the 20-750-ENC-1 tags if you choose to transmit this information from the drive. User defined tags can be used to add these bit names to your project.</p> <p>NOTE: The "Open Wire" error bit in the Error Status parameter (P6) will be set when any of bits P7.6 through P7.2 are also set. The "Open Wire" error bit is not set of bit P7.0, "RDC Velocity" is set.</p> <table border="1" style="width: 100%; border-collapse: collapse; margin-top: 10px;"> <thead> <tr> <th style="text-align: left;">Options</th> <th></th><th></th><th></th><th></th><th></th><th></th><th></th><th></th><th></th><th></th><th></th><th></th><th></th><th></th><th></th><th></th> </tr> <tr> <th></th> <th>Reserved</th><th>Reserved</th><th>Reserved</th><th>Reserved</th><th>Reserved</th><th>Reserved</th><th>Reserved</th><th>Reserved</th><th>Reserved</th><th>Reserved</th><th>Excessive Phase Err</th><th>RDC Clipping</th><th>RCD Loss</th><th>RDC Degrad</th><th>RDC Mismatch</th><th>RDC Tracking</th> </tr> </thead> <tbody> <tr> <td>Default</td> <td>0</td><td>0</td><td>0</td><td>0</td><td>0</td><td>0</td><td>0</td><td>0</td><td>0</td><td>0</td><td>0</td><td>0</td><td>0</td><td>0</td><td>0</td><td>0</td> </tr> <tr> <td>Bit</td> <td>15</td><td>14</td><td>13</td><td>12</td><td>11</td><td>10</td><td>9</td><td>8</td><td>7</td><td>6</td><td>5</td><td>4</td><td>3</td><td>2</td><td>1</td><td>0</td> </tr> </tbody> </table> <p>Bit 0: "RDC Velocity" - Velocity exceeds maximum limit of resolver/digital converter. See Resolver Tracking Speed on page 13 for more information. This bit will reset itself once the velocity reading decreases.</p> <p>Bit 1: "RDC Tracking" - RDC exceeded maximum tracking rate. Caused by extremely high acceleration values. This bit will reset itself once the acceleration rate decreases.</p> <p>Bit 2: "RDC Mismatch" - Maximum amplitude mismatch between the sine and cosine signals. Error in wiring or significantly higher impedance on one winding. (Cold solder joint, loose connection, etc.)</p> <p>Bit 3: "RDC Degrad" - Degradation in sine/cosine signals. Generally a wiring issue or electrical noise induced into the cable.</p> <p>Bit 4: "RDC Loss" - Sine/Cosine signals have changed significantly during machine operation and are now too low to be accurately measured. This is typically an indication of an installation issue or break/error in resolver cabling.</p> <p>Bit 5: "RDC Clipping" - Sine/Cosine signals have changed significantly during machine operation and are now too high to be accurately measured. This is typically an indication of an installation issue or break/error in resolver cabling.</p> <p>Bit 6: "Excessive Phase Err" - The phase shift between the Reference and Sine/Cosine signals has changed significantly during machine operation. This is usually an indication of an installation issue.</p> <p>Bits P7.6 through P7.2 are latched bits. Once set, they will remain on until cleared by a Clear Fault Command. These bits will trigger a Phase Loss event. See Troubleshooting on the following page for more information.</p>	Options																		Reserved	Reserved	Reserved	Reserved	Reserved	Reserved	Reserved	Reserved	Reserved	Reserved	Excessive Phase Err	RDC Clipping	RCD Loss	RDC Degrad	RDC Mismatch	RDC Tracking	Default	0	0	0	0	0	0	0	0	0	0	0	0	0	0	0	0	Bit	15	14	13	12	11	10	9	8	7	6	5	4	3	2	1	0		RO	Real
		Options																																																																								
	Reserved	Reserved	Reserved	Reserved	Reserved	Reserved	Reserved	Reserved	Reserved	Reserved	Excessive Phase Err	RDC Clipping	RCD Loss	RDC Degrad	RDC Mismatch	RDC Tracking																																																										
Default	0	0	0	0	0	0	0	0	0	0	0	0	0	0	0	0																																																										
Bit	15	14	13	12	11	10	9	8	7	6	5	4	3	2	1	0																																																										
		8	<p>Quad Loss Count Quadrature Loss Count</p> <p>Additional Resolver Status Information from the RD750.</p> <p>In the 20-750-ENC-1 module for Rockwell Automation, this parameter stores the number of times a quadrature loss error occurs within a one millisecond sample interval. There is no equivalent error in a resolver interface, so the RD750 uses this parameter to transmit additional resolver status information. Depending on which bits are set, this parameter value will be between 0 and 15.</p> <p>NOTE: The following bit names are designations from AMCI. They will not appear in the 20-750-ENC-1 tags if you choose to transmit this information from the drive. User defined tags can be used to add these bit names to your project.</p> <table border="1" style="width: 100%; border-collapse: collapse; margin-top: 10px;"> <thead> <tr> <th style="text-align: left;">Options</th> <th></th><th></th><th></th><th></th><th></th><th></th><th></th><th></th><th></th><th></th><th></th><th></th><th></th><th></th><th></th> </tr> <tr> <th></th> <th>Reserved</th><th>Reserved</th><th>Reserved</th><th>Reserved</th><th>Reserved</th><th>Reserved</th><th>Reserved</th><th>Reserved</th><th>Reserved</th><th>Reserved</th><th>Reserved</th><th>Reserved</th><th>Phase Shift</th><th>High TR</th><th>Low TR</th> </tr> </thead> <tbody> <tr> <td>Default</td> <td>0</td><td>0</td><td>0</td><td>0</td><td>0</td><td>0</td><td>0</td><td>0</td><td>0</td><td>0</td><td>0</td><td>0</td><td>0</td><td>0</td><td>0</td> </tr> <tr> <td>Bit</td> <td>15</td><td>14</td><td>13</td><td>12</td><td>11</td><td>10</td><td>9</td><td>8</td><td>7</td><td>6</td><td>5</td><td>4</td><td>3</td><td>2</td><td>1</td> </tr> </tbody> </table> <p>Bit 1: "Low TR" - The resolver's transformation ratio is lower than expected. The Sine/Cosine signals are present, but cannot be measured accurately. Decrease the TR setting on the RD750 to improve signal levels.</p> <p>Bit 2: "High TR" - The resolver's transformation ratio is higher than expected. The Sine/Cosine signals are present, but cannot be measured accurately. Increase the TR setting on the RD750 to improve signal levels.</p> <p>Bit 3: "Phase Shift" - Set to "1" if there is an error in measuring signal phase shift during initial tests. Set after power up sequence only.</p> <p>All used bits in P8 are latched bits. Once set, they will remain on until cleared by a Clear Fault Command. These bits will trigger a Quadrature Loss event. See Troubleshooting on the following page for more information.</p>	Options																	Reserved	Reserved	Reserved	Reserved	Reserved	Reserved	Reserved	Reserved	Reserved	Reserved	Reserved	Reserved	Phase Shift	High TR	Low TR	Default	0	0	0	0	0	0	0	0	0	0	0	0	0	0	0	Bit	15	14	13	12	11	10	9	8	7	6	5	4	3	2	1		RO	Real				
Options																																																																										
	Reserved	Reserved	Reserved	Reserved	Reserved	Reserved	Reserved	Reserved	Reserved	Reserved	Reserved	Reserved	Phase Shift	High TR	Low TR																																																											
Default	0	0	0	0	0	0	0	0	0	0	0	0	0	0	0																																																											
Bit	15	14	13	12	11	10	9	8	7	6	5	4	3	2	1																																																											

Table 4 RD750 Parameter List

TROUBLESHOOTING

Faults and Alarms

The following table contains information on the faults and alarms available when using the RD750.

NOTE  The parameter and bit names are defined for the 20-750-ENC-1 and these names will appear in your project. Review the descriptions below to understand how and when the drive will trigger a fault based on information from the RD750.

Event No. (†)	Fault / Alarm Text	Type	Fault Action	Configuration Parameters	Auto Reset	Description/Action(s)
xx000	Open Wire	Configurable		P3 [Fdbk Loss Cfg]		A position value cannot be determined due to errors in the sine/cosine signals. This bit is set when any of the status bits P7.6 through P7.2 (Phase Loss Count parameter) are set. The blink pattern of the Resolver Status LED (LED2) will also indicate the error.
xx001	Phase Loss	Configurable		P3 [Fdbk Loss Cfg]		The drive checks the value of the Phase Loss Count parameter (P7) every millisecond and calculates a running sum over an eight millisecond time period. This fault occurs whenever the eight millisecond sum exceeds 30. The RD750 defines seven status bits in the Phase Loss Count parameter (P7.6 - P7.0). Bits P7.0, RDC Velocity and P7.1, RCD Tracking, are not latched and will not cause this event to be triggered if they are the only bits in P7 that are on. The remaining bits used in P7, P7.6 through P7.2 are latched. Therefore, this event will occur within eight milliseconds of any of these five bits turning on. The only way to reset these five bits in P7 is with a by a Clear Fault Command.
xx002	Quadrature Loss	Configurable		P3 [Fdbk Loss Cfg]		The drive checks the value of the Quadrature Loss Count parameter (P8) every millisecond and calculates a running sum over an eight millisecond time period. This fault occurs whenever the eight millisecond sum exceeds 10. The RD750 defines three status bits in the Quad Loss Count parameter (P8.3 - P8.1). All of these bits are latched. Therefore, this event will occur within eight milliseconds of any of these three bits turning on. The only way to reset the bits in P8 is with a by a Clear Fault Command.
xx058	Module Defaulted	Fault	Coast			Module was commanded to write default values.

† The “xx” in the Event Number is equal to the slot the RD750 is installed in. For example, if the RD750 is installed in slot 5, a Phase Loss error will be reported as Event Number 05001.

Table 5 RD750 Faults and Alarms

SOFTWARE CONFIGURATION

Drive Add On Profiles

A PowerFlex 750-Series drive can be added to RSLogix 5000 or Studio 5000 projects as a “Standard Drive” using Drive Add-On Profiles (AOPs). RSLogix 5000 v16 and higher, or Studio 5000 is required. At the time of this writing, Add-On Profiles were available at <http://www.ab.com/support/abdrives/webupdate/software.html> under the “RSLogix 5000 Drive Add-On Profiles (non CIP Motion)” folder.

Option Modules are added to the drive while setting the drive’s properties.

Integrated Motion

PowerFlex 750-Series drives can be used as part of an Integrated Motion system. (Integrated Motion was previously known as *CIP Motion*.) With its 20-750-ENC-1 emulation, the RD750 can be used in Integrated motion systems.

NOTE  Like the 20-750-ENC-1 module, homing and registration functions are not supported when using the RD750 with Integrated Motion. These functions are only supported by the Universal Feedback Board (20-750-UFB-1) when Integrated Motion is used.

Rockwell Automation literature should be followed to add a PowerFlex drive to your control system. Rockwell Automation publication MOTION-UM003D explains how to create a new project that supports integrated motion as well as how to add and configure a PowerFlex 755 drive. When creating your project, remember to:

- Enable Time Synchronization
- Choose an Ethernet communications module that supports the CIP Sync protocol and verify that the following parameters are set correctly:
 - The Electronic Keying parameter must be set to “Exact Match” or “Compatible Keying”
 - The Time Sync Connection parameter must be set to “Time Sync and Motion”

Detailed information on configuring PowerFlex 755 drives for use with ControlLogix L6x and L7x controllers can be found in the following Rockwell Automation publications:

- PowerFlex 750-Series AC Drives, publication **750-PM001**
- Integrated Motion on the EtherNet/IP Network Configuration and Startup, publication **MOTION-UM003**
- Logix5000 Controllers Motion Instructions, publication **MOTION-RM002**
- Integrated Motion on the EtherNet/IP Network, publication **MOTION-RM003**

Connected Components Workbench

PowerFlex 750-Series drives can be configured with the Connected Components Workbench software. This software is available for free download at <http://ab.rockwellautomation.com/programmable-controllers/connected-components-workbench-software>. When installing the software, verify that the drive profiles are selected for installation, and not just the micro800 profiles.

Option Modules are added to the drive while setting the drive’s properties. Help files that were installed with the software are available to assist you.

DriveTools / DriveExecutive

DriveExecutive software recognizes all peripheral cards installed in a drive when the software connects to the drive and you upload data from the drive. You cannot manually add a 20-750-ENC-1 peripheral card to a 750-Series drive while off-line. Once the upload is complete, the RD750 will appear as a 20-750-ENC-1 card in the Node Tree.

Software Configuration

Notes



ADVANCED MICRO CONTROLS INC.

20 GEAR DRIVE, TERRYVILLE, CT 06786 T: (860) 585-1254 F: (860) 584-1973

www.amci.com



Waste Electrical and Electronic Equipment (WEEE)

At the end of life, this equipment should be collected separately from any unsorted municipal waste.