

DC25

Absolute Digital Output DuraCoder

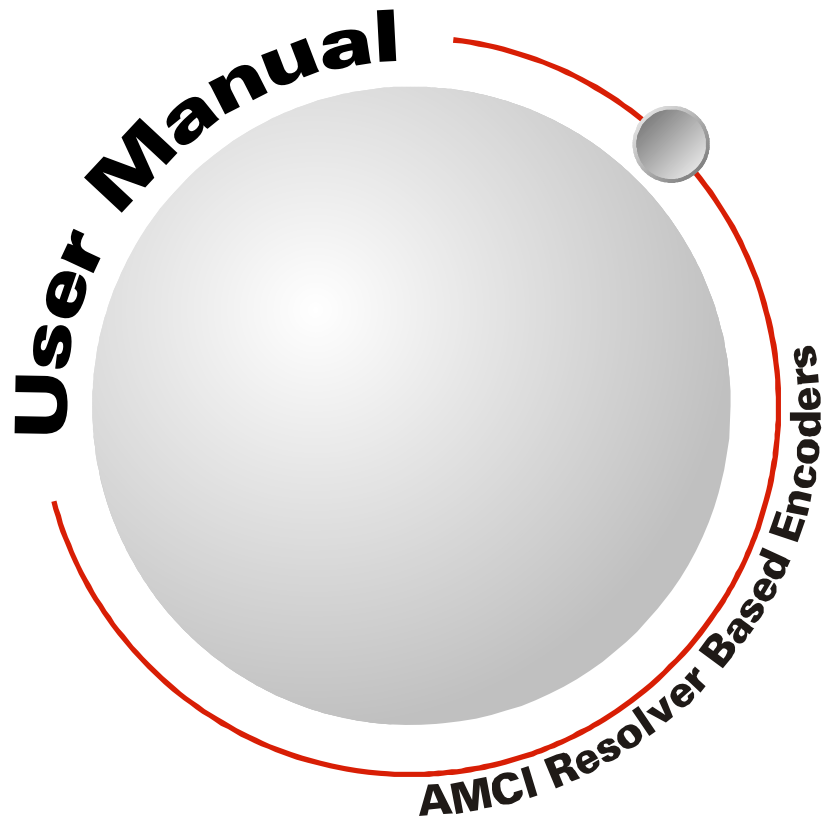

GENERAL INFORMATION

Important User Information

The products and application data described in this manual are useful in a wide variety of different applications. Therefore, the user and others responsible for applying these products described herein are responsible for determining the acceptability for each application. While efforts have been made to provide accurate information within this manual, AMCI assumes no responsibility for the application or the completeness of the information contained herein.

UNDER NO CIRCUMSTANCES WILL ADVANCED MICRO CONTROLS, INC. BE RESPONSIBLE OR LIABLE FOR ANY DAMAGES OR LOSSES, INCLUDING INDIRECT OR CONSEQUENTIAL DAMAGES OR LOSSES, ARISING FROM THE USE OF ANY INFORMATION CONTAINED WITHIN THIS MANUAL, OR THE USE OF ANY PRODUCTS OR SERVICES REFERENCED HEREIN.

No patent liability is assumed by AMCI, with respect to use of information, circuits, equipment, or software described in this manual.

The information contained within this manual is subject to change without notice.

This manual is copyright 2018 by Advanced Micro Controls Inc. You may reproduce this manual, in whole or in part, for your personal use, provided that this copyright notice is included. You may distribute copies of this complete manual in electronic format provided that they are unaltered from the version posted by Advanced Micro Controls Inc. on our official website: www.amci.com. You may incorporate portions of this documents in other literature for your own personal use provided that you include the notice "Portions of this document copyright 2018 by Advanced Micro Controls Inc." You may not alter the contents of this document or charge a fee for reproducing or distributing it.

Standard Warranty

ADVANCED MICRO CONTROLS, INC. warrants that all equipment manufactured by it will be free from defects, under normal use, in materials and workmanship for a period of [18] months. Within this warranty period, AMCI shall, at its option, repair or replace, free of charge, any equipment covered by this warranty which is returned, shipping charges prepaid, within eighteen months from date of invoice, and which upon examination proves to be defective in material or workmanship and not caused by accident, misuse, neglect, alteration, improper installation or improper testing.

The provisions of the "STANDARD WARRANTY" are the sole obligations of AMCI and excludes all other warranties expressed or implied. In no event shall AMCI be liable for incidental or consequential damages or for delay in performance of this warranty.

Returns Policy

All equipment being returned to AMCI for repair or replacement, regardless of warranty status, must have a Return Merchandise Authorization number issued by AMCI. Call (860) 585-1254 with the model number and serial number (if applicable) along with a description of the problem during regular business hours, Monday through Friday, 8AM - 5PM Eastern. An "RMA" number will be issued. Equipment must be shipped to AMCI with transportation charges prepaid. Title and risk of loss or damage remains with the customer until shipment is received by AMCI.

24 Hour Technical Support Number

24 Hour technical support is available on this product. If you have internet access, start at www.amci.com. Product documentation and FAQ's are available on the site that answer most common questions.

If you require additional technical support, call (860) 583-1254. Your call will be answered by the factory during regular business hours, Monday through Friday, 8AM - 5PM Eastern. During non-business hours an automated system will ask you to enter the telephone number you can be reached at. Please remember to include your area code. The system will page an engineer on call. Please have your product model number and a description of the problem ready before you call.

Waste Electrical and Electronic Equipment (WEEE)



At the end of life, this equipment should be collected separately from any unsorted municipal waste.

TABLE OF CONTENTS

General Information

Important User Information	2
Standard Warranty	2
Returns Policy	2
24 Hour Technical Support Number	2
WEEE Statement	2

About This Manual

Audience	5
Navigating this Manual	5
Manual Conventions	5
Trademarks and Other Legal Stuff	5
Revision Record	5
Where to Go From Here	6

Reference 1: The Absolute Digital DuraCoder

Absolute Digital DuraCoder Overview ...	7
Absolute Digital DuraCoder	
Diagnostics	7
Part Numbering System	8
Description of Outputs	8
Output Codecs	8
Output Update Control	8
Output Electrical Configurations ...	9
Status LED	9
Normal Operation	
(Test Pin open)	9
Test Mode	
(Test Pin grounded)	9
Electrical Specifications	10
Environmental Specifications	10
Mechanical Specifications	10

Task 1: Installation

Flange Mount Outline Drawings	11
End Connector	11
Side Connector	11
Alternate Shafts	12
Shaft Loading	12
Servo Mount Outline Drawings	13
End Connector	13
Side Connector	13
Alternate Shafts	14
Shaft Loading	14
Blind Shaft Mount Outline Drawings	15
End Connector	15
Side Connector	16
Available Shaft Diameters	16
Shaft Loading	16
5/8" Shaft Outline Drawings	17
End Connector	17
Side Connector	18
Shaft Loading	19
Connector Pinout	19

Task 2: Diagnostics

Output States	21
Over Voltage and	
Under Voltage Detection	21
Error Output	22
Test Input	22
Normal Operation	
(Test Pin Open)	22
Test Mode	
(Test Pin Tied to GND)	23
Testing Sourcing Output DuraCoders	23
High True Output Units	23
Low True Output Units	23
Testing Sinking Output DuraCoders	24
High True Output Units	24
Low True Output Units	24

Notes

ABOUT THIS MANUAL

Read this chapter to learn how to navigate through this manual and familiarize yourself with the conventions used in it. The last section of this chapter highlights the manual's remaining chapters and their target audience.

Audience

This manual explains the installation and operation of AMCI's absolute digital output DuraCoders. It is written for the engineer responsible for incorporating the Absolute Digital DuraCoder into a design as well as the engineer or technician responsible for its actual installation. If there are any unanswered questions after reading this manual, call the factory. An applications engineer will be available to assist you.

Navigating this Manual

This manual is designed to be used in both printed and on-line forms. Its on-line form is a PDF document, which requires Adobe Acrobat Reader version 7.0+ to open it. You are allowed add notes and annotations as well as select and copy sections for use in other documents. If you decide to print out this manual, all sections contain an even number of pages which allows you to easily print out a single chapter on a duplex (two-sided) printer.

Manual Conventions

Three icons are used to highlight important information in the manual:



NOTES highlight important concepts, decisions you must make, or the implications of those decisions.



CAUTIONS tell you when equipment may be damaged if the procedure is not followed properly.



WARNINGS tell you when people may be hurt or equipment may be damaged if the procedure is not followed properly.

The following table shows the text formatting conventions:

Format	Description
Normal Font	Font used throughout this manual.
<i>Emphasis Font</i>	Font used the first time a new term is introduced.
Cross Reference	When viewing the PDF version of the manual, clicking on the cross reference text jumps you to referenced section.
HTML Reference	When viewing the PDF version of the manual, clicking on the HTML reference text will open your default web browser to the referenced web page.

Trademarks and Other Legal Stuff

The AMCI logo is a trademark, and "DuraCoder" is a registered trademark of Advanced Micro Controls Inc. "Adobe" and "acrobat" are registered trademarks of Adobe Systems Incorporated.

All other trademarks contained herein are the property of their respective holders.

Revision Record

This manual, 940-0D043 is the fourth release of the manual. It adds information on the new diagnostic capabilities and the alterations to the connector pinout. It was first released October 31th, 2018.

ABOUT THIS MANUAL

Where to Go From Here

The table below gives a brief description of the content of each chapter to help you find the information you need to assist you in your job.

CHP NUM.	Chapter Title	Chapter Description
Reference 1	<i>The Absolute Digital DuraCoder</i>	Intended for anyone new to the Absolute Digital DuraCoder, this chapter gives a basic overview of the unit. The chapter also explains the Absolute Digital DuraCoder part numbering system.
Task 1	<i>Installation</i>	This chapter is intended for the engineer or technician responsible for installing and wiring the Absolute Digital DuraCoder. Information in this chapter includes mechanical drawings, installation guidelines and connector pinout.
Task 2	<i>Diagnostics</i>	This chapter explains the diagnostics available on the latest revision of the absolute digital DuraCoders. A status LED has been added on the rear cover of the revised DuraCoders.

THE ABSOLUTE DIGITAL DURACODER

Absolute Digital DuraCoder Overview

DuraCoders are designed as direct replacements for optical encoders. Instead of being designed around a disk and optics, a DuraCoder uses a resolver as its primary shaft position sensor. Constructed in a manner similar to high precision motors, resolvers are absolute, single turn position sensors that are unsurpassed in terms of ruggedness and reliability. The resolver is an analog device whose outputs vary sinusoidally as the shaft is rotated. If you are interested in learning more about resolvers, read the article on our website at: <https://www.amci.com/industrial-automation-resources/plc-automation-tutorials/what-resolver/>.

The resolver's analog signals are decoded into a 12 bit position value by electronics incorporated into the DuraCoder. This 12 bit (4096 count), absolute position value is available as a parallel digital output. Several different output codes and voltage level outputs are available.

In addition to the actual position outputs, the Absolute Digital DuraCoders also offer two inputs that control the outputs. The Latch Input is used to control when the position values update and the Direction Input controls the direction of rotation needed to produce increasing counts.

The Absolute Digital DuraCoder is available in a variety of industry standard size 25 optical encoder packages. A flange mount unit with a 3/8" shaft and a side connector is shown in figure R1.1. Servo mount and end connect units are also available. If your application requires you to mount the DuraCoder to a motor, a blind shaft mounting option is available as well. Finally, a face mount unit with a 5/8 inch shaft is available for applications that may be exposed to high shaft loads.

Outline drawings of all of the packing options is available in the *Outline Drawings* section of the [Installation](#) chapter, starting on page 11.



Figure R1.1 An Absolute Digital DuraCoder

Absolute Digital DuraCoder Diagnostics

Starting in August of 2018, Absolute Digital DuraCoders include additional diagnostic features.

- **Fault Output** - This output is active during normal operation and goes inactive when one or more of the following conditions exists:
 - 1) Over temperature of the output drivers
 - 2) Output shorted to ground
 - 3) Output shorted to Vdc
 - 4) Open connection or wire.
- **Test Input** - Used to test the outputs of the unit. This single input can be used to force all of the outputs into their active or inactive states. A full explanation of the uses of this pin can be found in [Task 2, Diagnostics](#) starting on page 21.
- **Status LED** - Located on the back of the unit, this LED shows the status of the unit under normal operating conditions, and the status of the outputs when used with the Test Pin.

THE ABSOLUTE DIGITAL DURACODER

Part Numbering System

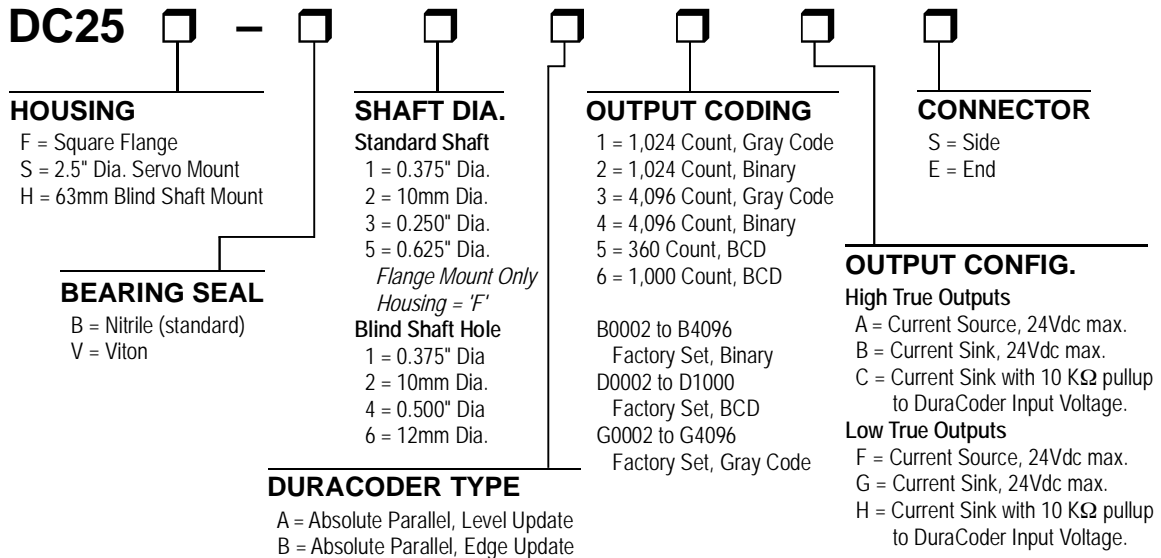

Figure R1.2 Part Numbering System

Description of Outputs

Output Codecs

The Absolute Digital DuraCoder can output its data in 12 bit Natural Binary, 12 bit Gray Code, or 12 bit BCD formats. In Natural Binary and Gray Code formats, the maximum output value is 4,095. For BCD format, the maximum output value is 999.

NOTE In new installations, the sole advantage of Gray Code over Natural Binary is that only one bit changes per count. This allows you to easily check the validity of the position data. This one bit change holds true only if your number of counts per turn is a power of two. (2, 4, 8, ... 4,096) If your number of counts per turn is not set to a power of two, the transition between your maximum count and zero will result in two or more bits changing in the data.

Output Update Control

Position data updates are controlled by a single pin named *Latch Control* and the type of control is set when the DuraCoder is ordered. Two types of position update control are available.

- **Level Sensitive (Part # starts: DC25?-??A)** – The position data updates every 325 microseconds while the Latch Control pin is at a Logic 1 voltage or the pin is left open. The position data will freeze within 25 microseconds of this pin being driven to a Logic 0 voltage. The position data will begin to update within 325 microseconds once it is released from the Logic 0 voltage level. If the Latch Control pin is at a Logic 0 on power up, all outputs will be in their zero state until the first positive transition. Position data will not be valid until this transition.

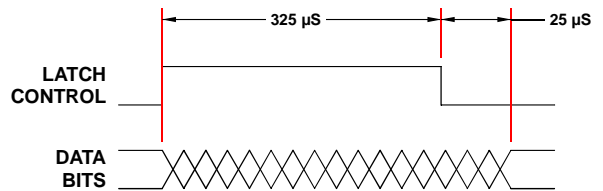

Figure R1.3 Level Sensitive Update

Description of Outputs (continued)

Output Update Control (continued)

- **Edge Sensitive (Part # starts: DC25?-??B)** – A Logic 0 → 1 or 1 → 0 transition on the Latch Control input will update the outputs within 325 microseconds. The output will then freeze until another valid transition. Transitions must be a minimum of 325 microseconds apart. (1.5 kHz at a 50% duty cycle maximum.) On power up, all of the outputs will be in their zero state until the first valid transition occurs. Position data will not be valid until this transition.

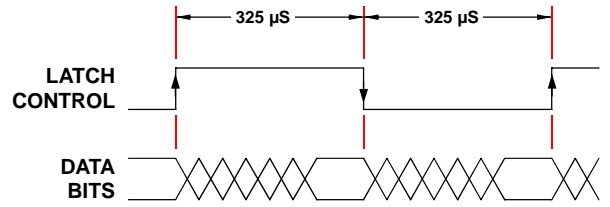

Figure R1.4 Edge Sensitive Update

Output Electrical Configurations

Three different electrical configurations are available for the outputs.

- Open Collector Sourcing
- Open Collector Sinking
- Open Collector Sinking with a 10KΩ resistor to +Vin

Full characteristics for the output are available in the *Electrical Specifications* section on the following page.

Outputs can be ordered as a High True Output or a Low True Output. The table below shows the states.

	High True		Low True	
	Logic 1	Logic 0	Logic 1	Logic 0
Open Collector Source Output	Conducts to VIN	High-Impedance	High-Impedance	Conducts to VIN
Open Collector Sink Output	High-Impedance	Conducts to GND	Conducts to GND	High-Impedance
Sink Output w/ 10 KΩ Pullup	High-Impedance Pulled to VIN through 10 KΩ	Conducts to GND	Conducts to GND	High-Impedance Pulled to VIN through 10 KΩ

Figure R0.1 Output States

Status LED

As shown in figure R1.5, the Status LED is located on the back of the unit.

Normal Operation (Test Pin open)

- **Steady Green** - The encoder is operating normally without a fault.
- **Steady Red** - One or more of the following fault conditions exists:
 - 1) Over temperature of the output drivers
 - 2) Output shorted to ground
 - 3) Output shorted to Vdc
 - 4) Open connection or wire.

Test Mode (Test Pin grounded)

- **OFF** - The output are acting normally.
- **ON** - A fault condition exists on one or more of the outputs. See Task 2, *Diagnostics* starting on page 21 for information on diagnosing the error condition.

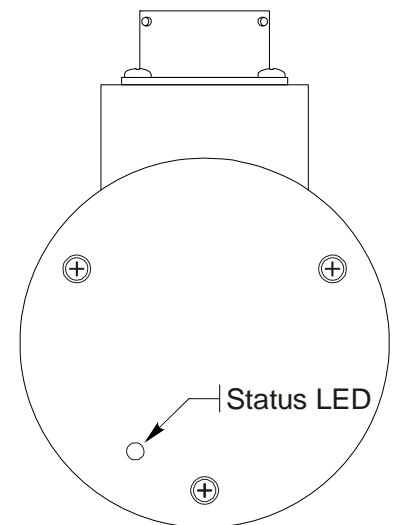

Figure R1.5 Status LED Location

Electrical Specifications

Operating Voltage

10.8 Vdc to 26.4Vdc (12 to 24 Vdc nominal)

Power Requirements

1.2 W max. (50mA @ 24Vdc)
All outputs in their inactive state.

Position Resolution

2 to 4,096 counts with Gray Code or Natural Binary output format.

2 to 1,000 counts with BCD output format

Position Update Control

Latch Control pin on connector that is factory set to either Level control or Edge control.

With Level control, the outputs update continuously while pin is at a logic 1 or open circuit. Outputs freeze when input tied to DC Return.

With Edge control, outputs update within 325 microseconds of a transition from logic 0 to logic 1 or logic 1 to logic 0. Transitions must occur at a minimum of 325 microseconds apart. (1.5KHz at 50% duty cycle)

Logic Level Input Voltages

Logic 0: 0 Vdc to 0.8 Vdc.

Logic 1: 2 Vdc to Operating Voltage.
Inputs have pull up resistors, so leaving them disconnected will act as a logic "1"

Position Update Time

325 microseconds when using Level update control and the Latch Control pin has been at a logic 1 or open circuit for a minimum of 325 microseconds

Max. Output Settling Time

325 microseconds. Occurs on either transition when using Edge control or when Latch Control pin changes from Logic 0 to Logic 1 state when using Level control.

Direction of Increasing Counts

Default CCW looking at shaft

Can be set to CW increasing by shorting pin R to DC Return.

Output Types

Open Collector Sourcing, Open Collector Sinking, and Sinking with 10 K Ω pull-up resistor.

On State Current

500 mA per output without damage.

On State Resistance

0.75 Ω max. (0.03 Vdc drop across driver at 40 mA)

Leakage Current

5 microamps maximum

Environmental Specifications

Operating Temperature

-40°F to +185°F (-40°C to +85°C)

Shock

50g, 11 millisecond duration

Vibration

20g, 5 to 2000Hz

Enclosure Rating

IP67

Approximate Weight

2.0 lbs. (0.91 Kg) 0.625" shafts

1.4 lbs. (0.65 Kg) All other shafts

Mechanical Specifications

Package Style

2.5 inch aluminum housing with flange, servo, or blind shaft mounting

Connector Location

Side or End

Housing

Powder coated aluminum

Shaft

0.250", 0.375", 0.625", or 10mm

Blind Shaft with 0.375", 0.500", 10mm or 12 mm hole

Max. Starting Torque @ 25°C

2.0 oz-in: 0.250", 0.375", and 10mm shafts

6.0 oz-in: All blind shafts

6.0 oz-in: 0.625" shaft

Moment of Inertia (oz-in-sec²)

6.00 X 10⁻⁴: 0.250", 0.375", and 10mm shafts

7.00 X 10⁻⁴: All blind shafts

8.50 X 10⁻⁴: 0.625" shaft

Max. Operating Speed

6000 RPM

Max. Shaft Loading (0.625" shaft)

Axial: 50 lbs. (222 N)

Radial: 100 lbs. (445 N)

As specified max. loads, bearing life is 2X10⁹ revolutions min.

Max. Shaft Loading (All other shafts)

Axial: 20 lbs. (89 N)

Radial: 40 lbs. (178 N)

As specified max. loads, bearing life is 2X10⁹ revolutions minimum.

TASK 1

INSTALLATION

Flange Mount Outline Drawings

End Connector

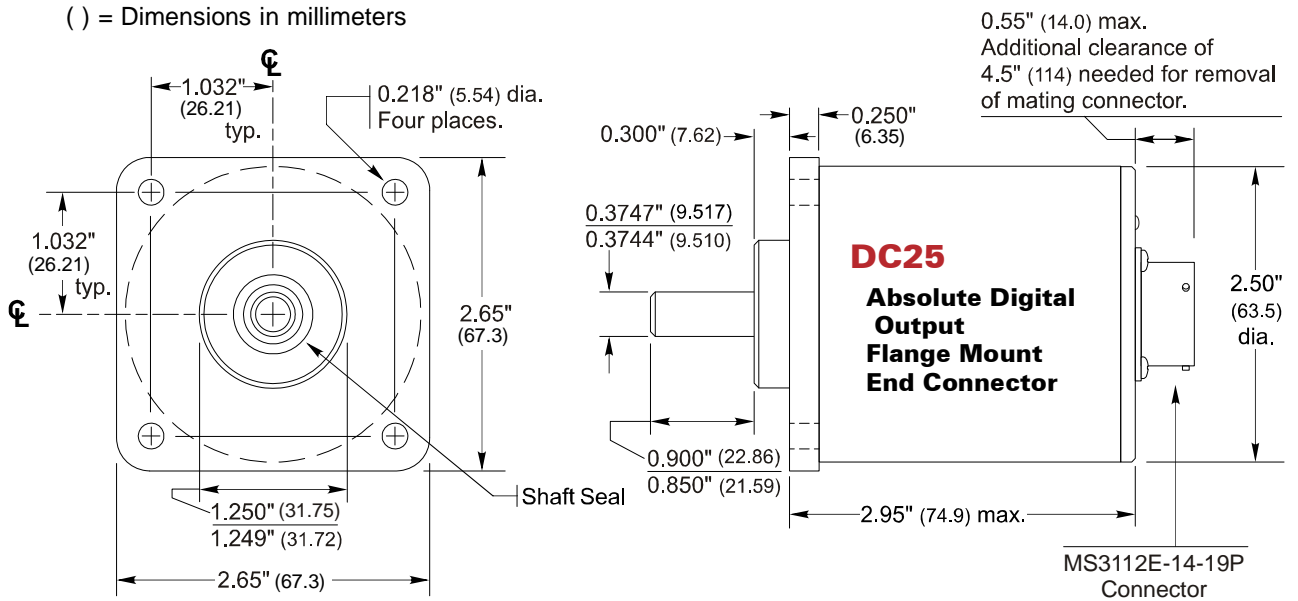

Figure T1.1 Flange Mount, End Connect Outline Drawing

Side Connector

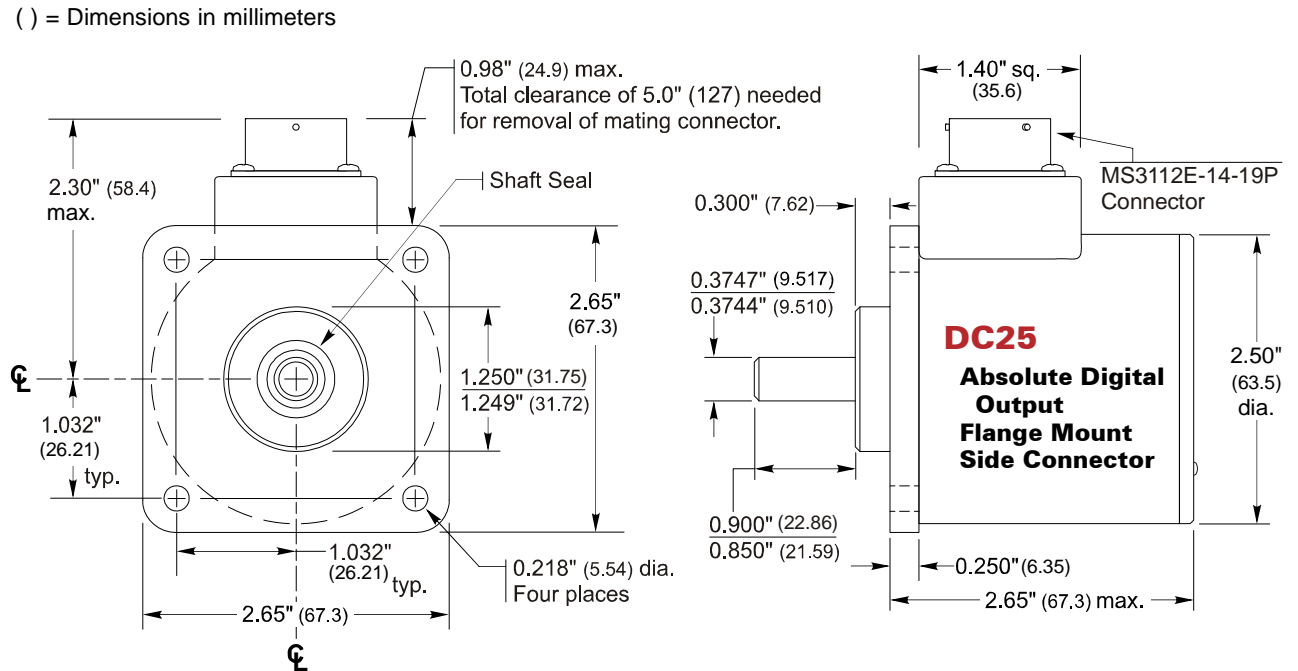

Figure T1.2 Flange Mount, Side Connect Outline Drawing

INSTALLATION

Flange Mount Outline Drawings (continued)

Alternate Shafts

10mm Shaft (Shaft Option 2)

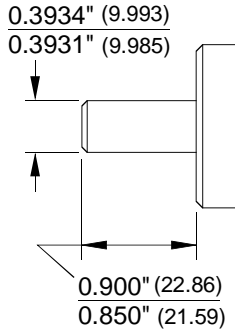

1/4" Shaft (Shaft Option 3)

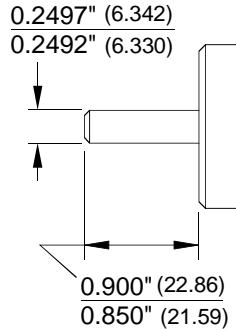

() = Dimensions in mm

Figure T1.3 Flange Mount Alternate Shafts

Shaft Loading

Limit shaft loading to the following values. These values statistically yield an L10 life of 2×10^9 revolutions. (L10 life is a rating which means that statistically, only 10% of the bearings will have failed after 2×10^9 revolutions.) Shaft loading has an exponential effect on bearing life. The bearings will statistically last longer if you can limit shaft loading below the given values. Consider using the 5/8" shaft DuraCoder from AMCI if your shaft loading is expected to be greater than the values given below. Outline drawings for the 5/8" shaft DuraCoders start on page 17.

Radial Load	Axial Load
40 lbs. (178 N)	20 lbs. (88 N)

Table T1.1 Flange Mount Shaft Loading

Servo Mount Outline Drawings

End Connector

() = Dimensions in millimeters

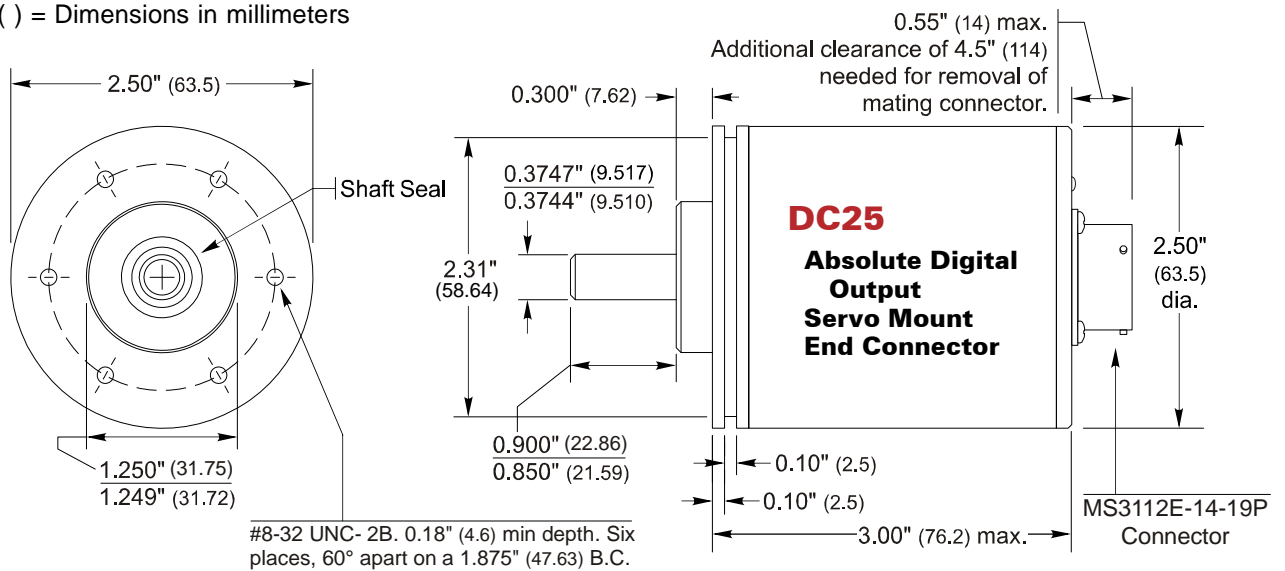

Figure T1.4 Servo Mount, End Connect Outline Drawing

Side Connector

() = Dimensions in millimeters

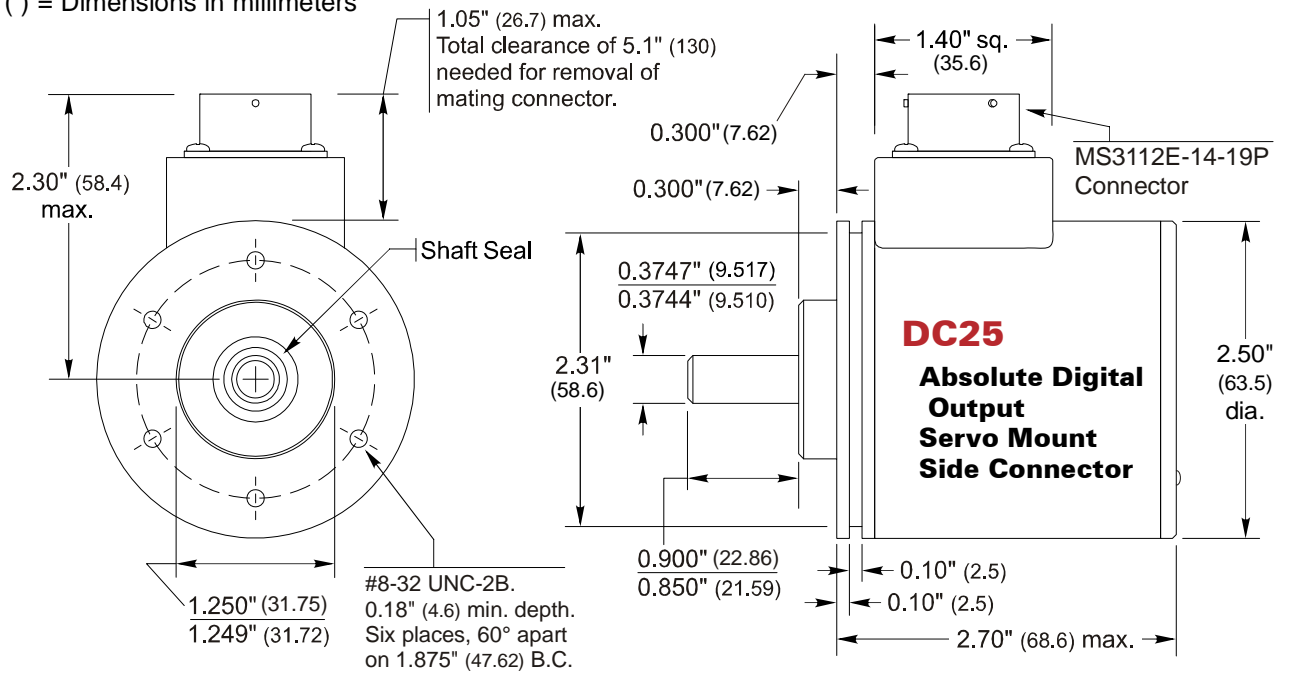

Figure T1.5 Servo Mount, Side Connect Outline Drawing

INSTALLATION

Servo Mount Outline Drawings (continued)

Alternate Shafts

10mm Shaft (Shaft Option 2)

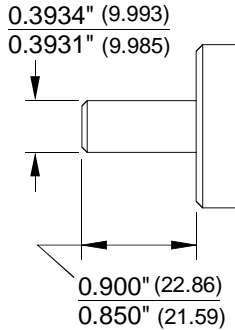

1/4" Shaft (Shaft Option 3)

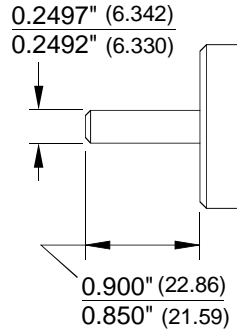

() = Dimensions in mm

Figure T1.6 Servo Mount Alternate Shafts

Shaft Loading

Limit shaft loading to the following values. These values statistically yield an L10 life of 2×10^9 revolutions. (L10 life is a rating which means that statistically, only 10% of the bearings will have failed after 2×10^9 revolutions.) Shaft loading has an exponential effect on bearing life. The bearings will statistically last longer if you can limit shaft loading below the given values. Consider using the 5/8" shaft DuraCoder from AMCI if your shaft loading is expected to be greater than the values given below. Outline drawings for the 5/8" shaft DuraCoders start on page 17.

Radial Load	Axial Load
40 lbs. (178 N)	20 lbs. (88 N)

Table T1.2 Servo Mount Shaft Loading

Blind Shaft Mount Outline Drawings

End Connector

() = Dimensions in millimeters

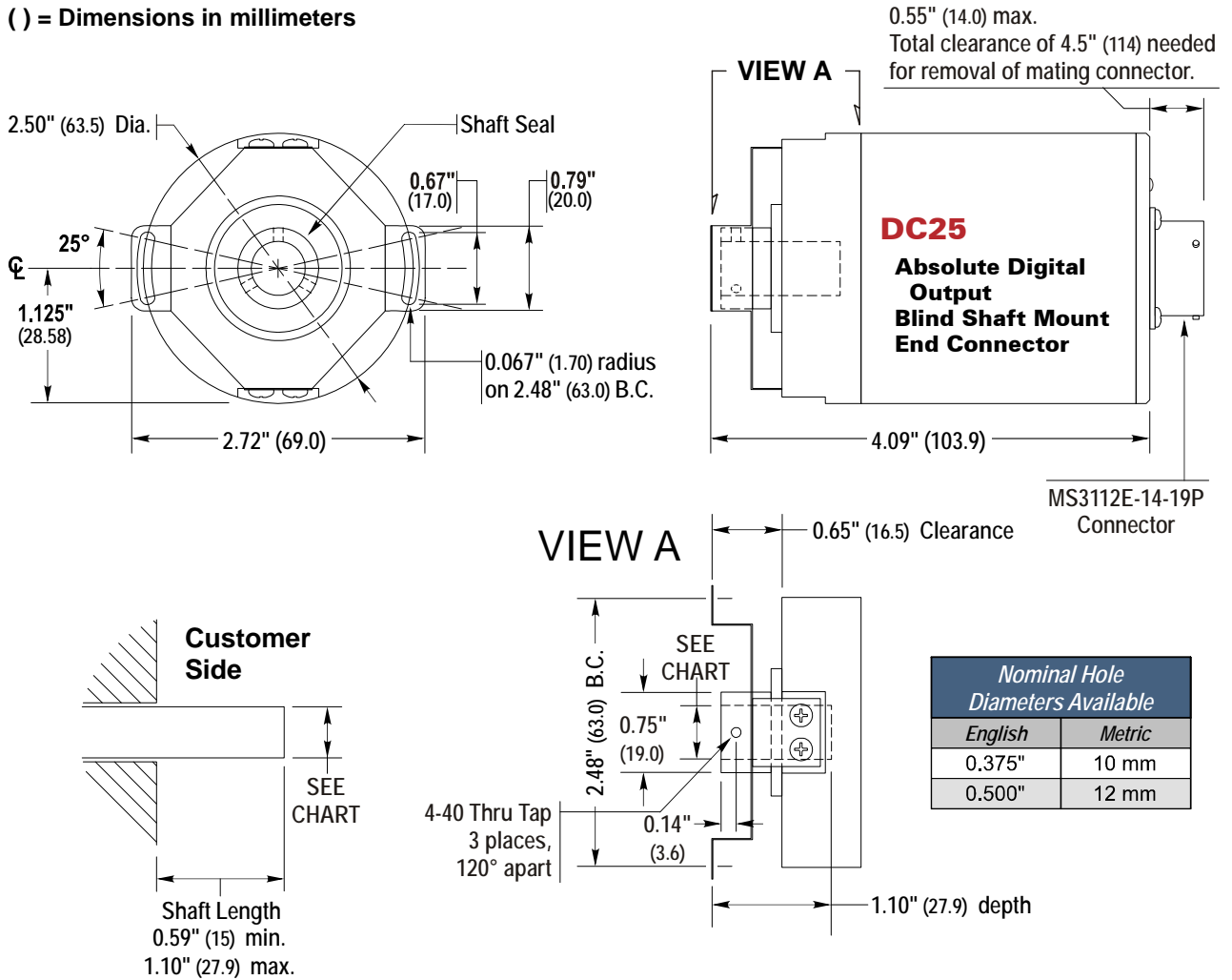

Figure T1.7 Blind Shaft Mount, End Connect Outline Drawing

INSTALLATION

Blind Shaft Mount Outline Drawings (continued)

Side Connector

() = Dimensions in millimeters

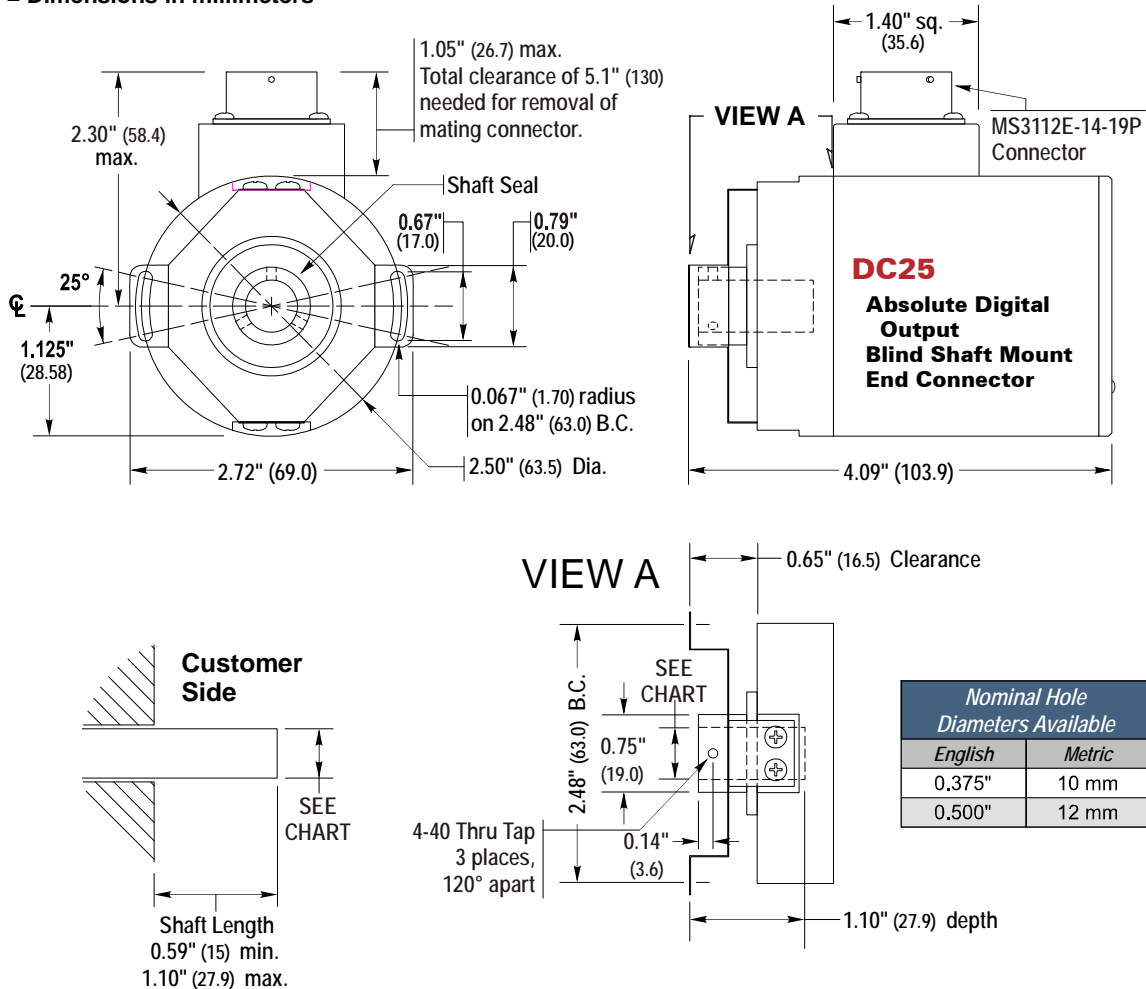

Figure T1.8 Blind Shaft Mount, Side Connect Outline Drawing

Available Shaft Diameters

The diameter of the drive shaft must be specified when ordering a blind shaft DuraCoder. Available options are given in the table below. Other diameter options may have become available after the release of this manual. Please check our website, www.amci.com, if you do not see the shaft diameter that fits your application.

Nominal Hole Diameters	
English	Metric
0.375"	10 mm
0.500"	12 mm

Table T1.3 Available Blind Shaft Diameters

Shaft Loading

The load that the Analog DuraCoder presents to your input shaft, which is equal to the load presented to the DuraCoder by your input shaft, is difficult to calculate and is dependent on the accuracy of the mounting. The flexible metal mounting bracket will be able to absorb most of the radial loading forces, but accurate mounting of the DuraCoder is still important.

5/8" Shaft Outline Drawings

End Connector

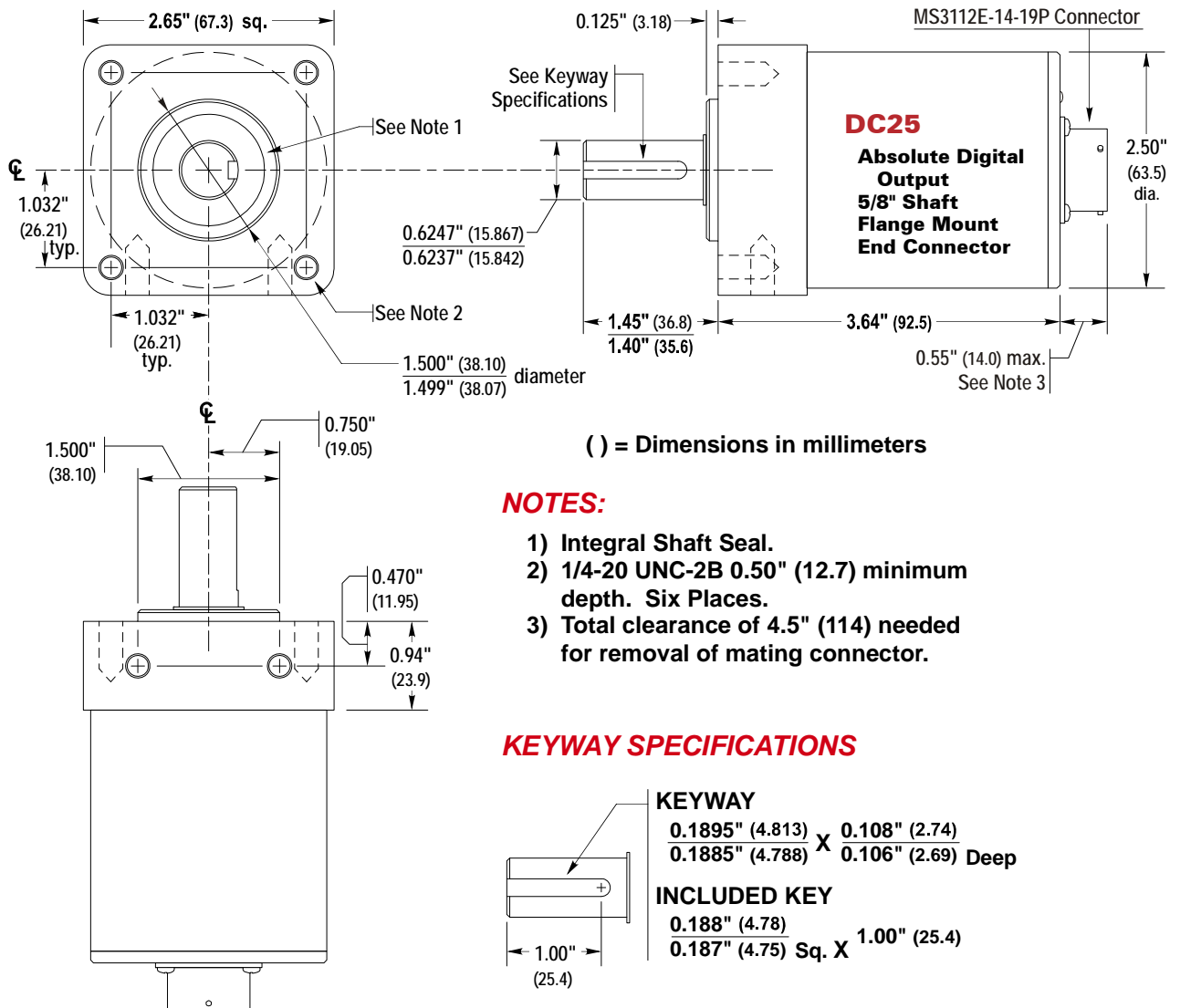

Figure T1.9 5/8" Shaft, Face Mount, End Connect Outline Drawing

INSTALLATION

5/8" Shaft Outline Drawings (continued)

Side Connector

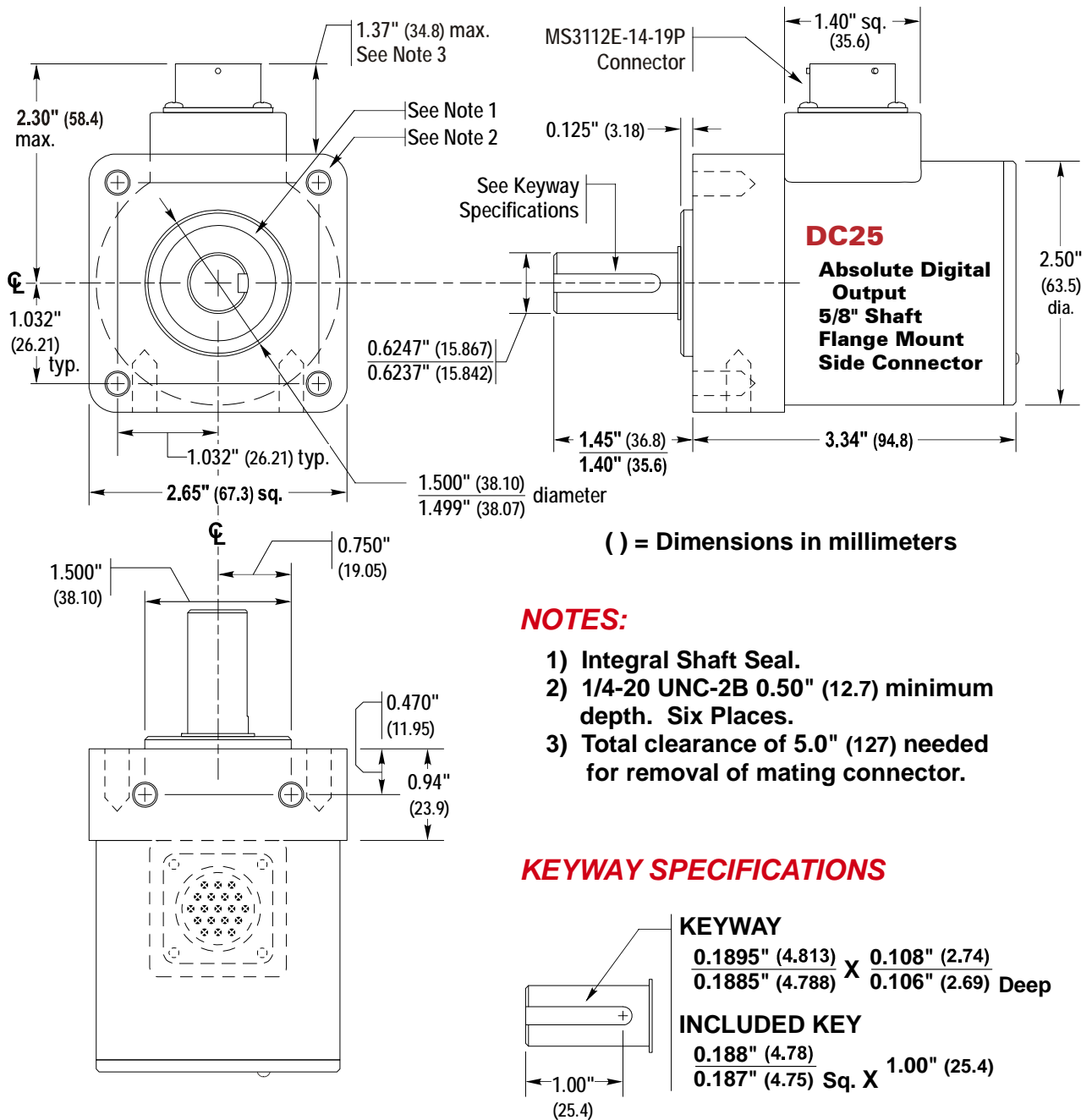

Figure T1.10 Flange Mount, Side Connect Outline Drawing

5/8" Shaft Outline Drawings (continued)

Shaft Loading

Limit shaft loading to the following values. These values statistically yield an L10 life of 2×10^9 revolutions. (L10 life is a rating which means that statistically, only 10% of the bearings will have failed after 2×10^9 revolutions.) Shaft loading has an exponential effect on bearing life. The bearings will statistically last longer if you can limit shaft loading below the given values.

Radial Load	Axial Load
100 lbs. (445 N)	50 lbs. (222 N)

Table T1.4 Flange Mount Shaft Loading

Connector Pinout

Figure T1.11 shows the pin designations on the MS3112E-14-19P connector. AMCI sells a straight mating connector under the AMCI part number: MS-19.

AMCI does not supply factory made cables for the Absolute Digital DuraCoder because of the many possible configurations.

Pins A-M: Position Output – These pins output the absolute position value. Pin A is the least significant bit.

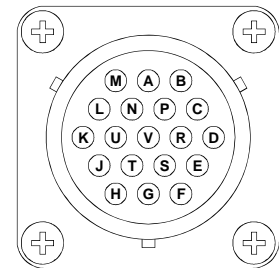

Figure T1.11 Connector Pinout

NOTE Prior to the August 2018 release of the Absolute Digital DuraCoder, the “N” and “P” pins were “No Connection” pins.

Pin N: Error Output – The output state of this pin is active during normal operation. It switches to its inactive state when there is a fault condition. The four detectable fault conditions are:

- Output driver over-temperature
- Output shorted to ground
- Output shorted to Vdc
- Open wire or connections

These faults are latched. Once they occur, the DuraCoder will report the error until it is cleared. There are two methods to clear the error.

- 1) Cycle power to the DuraCoder
- 2) Pull the Test input low for a minimum of 10 milliseconds and release it.

If the fault condition no longer exists, the Error output will return to its active and the Status LED on the back of the unit will change from red to green.

See table T2.2, *Output Voltage States*, found on page 21 for the output voltage levels when the output is active or inactive.

Pin P: Test Input – This pin is used to test the outputs of the DuraCoder and clear fault conditions. This pin should be left open for normal operation. Connecting this pin to GND will place the DuraCoder in test mode. The use of this pin is fully described in Task 2, *Diagnostics*, starting on page 21.

PIN	Function		
	Gray Code	Natural Binary	BCD (8421)
A	G(0)	2^0	1
B	G(1)	2^1	2
C	G(2)	2^2	4
D	G(3)	2^3	8
E	G(4)	2^4	10
F	G(5)	2^5	20
G	G(6)	2^6	40
H	G(7)	2^7	80
J	G(8)	2^8	100
K	G(9)	2^9	200
L	G(10)	2^{10}	400
M	G(11)	2^{11}	800
N	Error Output		
P	Test Input		
R	Direction Control Input		
S	Case GND		
T	DC Return		
U	Latch Control Input		
V	+DC Input		

Connector Pinout

Pin R: Direction Control – This pin controls which direction the shaft must rotate to increment the position data. With this pin open circuit, position data increases with CCW rotation, looking at the shaft. Connecting this pin to Pin T, (DC Return), forces the position to increase with CW rotation, looking at the shaft.

NOTE  If you want CW increasing counts, you must connect pins R and T at the connector or at the end of a short extension cable. Do not run a long cable pair from these pins and connect these pins at the other end of the cable. This may allow noise to be injected into the Direction Control pin that will affect the position count.

Pin S: Case GND – This pin should be used to tie the body of the DuraCoder to chassis ground *at the DuraCoder* if the unit is not grounded through its mounting. This pin is not to be used as the power supply return. The power supply must be wired to pins T (DC Return) and V (+DC Input).

Pin T: DC Return – This pin must be connected the power supply return. The power supply must be wired to pins T (DC Return) and V (+DC Input). This pin cannot be used to tie the body of the DuraCoder to chassis ground.

Pin U: Latch Control – The Latch Control input is fully described in the section [Output Update Control](#), found on page 8. Briefly here, there are two types of position data update control:

- **Level Sensitive:** The outputs update every 325 microseconds when the pin is open circuit or at a logic 1 voltage level. The outputs will freeze within 25 microseconds when a logic 0 voltage is applied. When the input transitions between a logic 0 and a logic 1, the outputs will take approximately 325 microseconds before they begin to update.
- **Edge Sensitive:** The outputs update within 325 microseconds of a 0→1 or 1→0 transition on the input. The outputs then freeze until another valid transition. Transitions must be at least 325 microseconds apart, which yields a maximum frequency of 1.5KHz with a 50% duty cycle. All of the outputs will be at a logic 0 state on power up until the first valid transition occurs.

Pin V: +DC Input – This pin must be connected to the high side of the power supply. The power supply must be wired to pins T (DC Return) and V (+DC Input).

TASK 2

DIAGNOSTICS

This chapter is specifically for the latest revision of the Absolute Digital DuraCoders that contain additional diagnostic features. These instructions only apply to units with a status LED on the rear cover.

Output States

The Absolute Digital DuraCoder offers both sinking and sourcing outputs. Therefore, these diagnostic instructions list the outputs as being in their active state or inactive state. (Conducting current, or not conducting current.) Table T2.1 below shows the expected output voltages when an output is in its two states. Refer to *Part Numbering System*, found on page 8 if you need to determine the type of outputs your DuraCoder has.

	High True Outputs (Output Config A,B,C)		Low True Outputs (Output Config F, G, H)	
	Logic 1 (Vdc)	Logic 0 (GND)	Logic 1 (GND)	Logic 0 (Vdc)
Open Collector Source (A or F)	Active	Inactive	Inactive	Active
Open Collector Sink Output (B or G)	Inactive	Active	Active	Inactive
Sink Output w/ 10 K Ω Pullup (C or H)	Inactive	Active	Active	Inactive

Table T2.1 Output Logic States

	Active	Inactive
Open Collector Source (Output Type A or F)	Conducting. Output voltage equals the input voltage to the DuraCoder.	Not Conducting. Output typically pulled to Ground through an external resistor.
Open Collector Sink Output (Output Type B or G)	Conducting. Output is at ground potential. (0 Vdc)	Not Conducting. Output typically pulled to an external voltage through an external resistor.
Sink Output w/ 10 K Ω Pullup (Output Type C or H)	Conducting. Output is at ground potential. (0 Vdc)	Not Conducting. Output pulled to the DuraCoder's power supply voltage through the internal 10 K Ω resistor.

Table T2.2 Output Voltage States

Over Voltage and Under Voltage Detection

The output driver IC on the DuraCoder has the ability to detect over voltage and under voltage conditions on the power supply and turn off the drivers if either condition occurs. This leaves the outputs in a known state instead of an uncertain state based on the power supply levels. However, this is a feature of the driver IC itself, and does not indicate to the DuraCoder that it is in this state.

Therefore, if the outputs are in their inactive state but the DuraCoder does not give any fault indication, check the power supply voltage and verify that it is within its acceptable range of 10.8 Vdc to 26.4Vdc.

Error Output

The Error output is the same driver type as the position outputs, with an internal pull-up or pull-down resistor. Therefore, the “high” voltage is equal to the voltage that powers the DuraCoder.

The output can sink or source a maximum of 500 milliamperes. It is designed to drive a typical PLC DC input. Figure T2.1 below shows how to wire the output to a typical DC input.

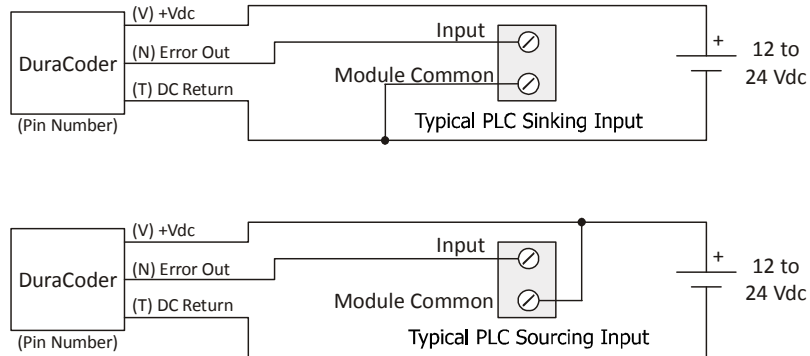

Figure T2.1 Error Output Wiring

For sinking output units, the output is low during normal operation. For sourcing output units, the output is high for normal operations. The output switches to its inactive state when one of the following conditions occurs:

- Over temperature fault on the output driver IC.
- One or more outputs shorted to ground.
- One or more outputs shorted to the input voltage of the DuraCoder.
- One or more outputs with an open connection or broken wire.

These faults are latched. Once they occur, the DuraCoder will report the error until it is cleared. There are two methods to clear the error.

- 1) Cycle power to the DuraCoder
- 2) Pull the Test input (Pin P) low for a minimum of 10 milliseconds and release it.

If the fault condition no longer exists, the Error output will return to its active state and the Status LED on the back of the unit will change from red to green.

Test Input

The Test input is a DC input with an internal pull-up resistor to the supply voltage of the DuraCoder. When the Test input is pulled low for a minimum of 325 microseconds, the DuraCoder is placed in test mode. The unit remains in test mode while the Test input is low. Once the Test input is released, the DuraCoder will return to its normal mode of operation within 325 microseconds.

Normal Operation (Test Pin Open)

During normal operation, the Status LED is in one of three states:

Status LED State	Description
OFF	No power to the DuraCoder.
Green	Operating normally
Red	A fault condition exists. See the <i>Error Output</i> section above for a list of detectable errors.

Table T2.3 Output Voltage States

If there are no faults, the state of the outputs is determined by the DuraCoder shaft position. If there is an overtemperature fault, all of the outputs are forced into their inactive state. For all other fault conditions, the state of the unaffected outputs is determined by the DuraCoder shaft position.

Test Input (continued)

Test Mode (Test Pin Tied to GND)

In Test mode, all of the outputs are forced into their active or inactive states. This is accomplished by pulling the Test input low for a minimum of 325 milliseconds. The DuraCoder remembers the last state the outputs were forced into. Once the Test input is released for a minimum of 325 milliseconds and pulled low again, the outputs will switch to their other test state. When the Test input is released for a minimum of 325 milliseconds, the unit exits Test Mode, and the outputs begin to output position data again.

Testing Sourcing Output DuraCoders

A pull down resistor or equivalent load is required when testing sourcing outputs. If this load is not present, a voltmeter may read that the output is active when it is in its inactive, high impedance, state due to leakage current through the output.

High True Output Units

High True output units have the output at 0 Vdc for a logic “0” and +Vdc for a logic “1”.

- ▶ If the Test Pin is pulled low when power is applied to the unit, all outputs are set to 0 Vdc. The drivers are not conducting and this is considered a logic “0”.
- 1) If the Test Pin is high or open during power up, the first time it is pulled low for greater than 325 milliseconds, all outputs are set to the +Vdc voltage. The drivers are conducting and this is considered a logic “1”. If the output voltage is at 0 Vdc, you have a short to ground or a wiring error.
- 2) Releasing the Test Input for more than 325 milliseconds will take the unit out of test mode and back to normal operation.
- 3) Pulling the Test Input low for greater than 325 milliseconds will place the unit back into test mode. All of the outputs are now set to 0 Vdc. The drivers are not conducting and this is considered a logic “0”. If the output voltage is at +Vdc, you have a short to +Vdc or a wiring error.
- 4) Releasing the Test Input for more than 325 milliseconds will take the unit out of test mode and back to normal operation.

Repeating steps 1 through 4 will force the outputs to alternate between their logic “1” and “0” states.

Low True Output Units

Low True output units have the output at 0 Vdc for a logic “1” and +Vdc for a logic “0”.

- ▶ If the Test Pin is pulled low when power is applied to the unit, all outputs are set to the +Vdc voltage. The drivers are conducting and this is considered a logic “0”.
- 1) If the Test Pin is high or open during power up, the first time it is pulled low for greater than 325 milliseconds, all outputs are set to 0 Vdc. The drivers are not conducting and this is considered a logic “1”. If the output voltage is at +Vdc, you have a short to +Vdc or a wiring error.
- 2) Releasing the Test Input for more than 325 milliseconds will take the unit out of test mode and back to normal operation.
- 3) Pulling the Test Input low for greater than 325 milliseconds will place the unit back into test mode. All of the outputs are now set to the +Vdc voltage. The drivers are conducting and this is considered a logic “0”. If the output voltage is at 0 Vdc, you have a short to ground or a wiring error.
- 4) Releasing the Test Input for more than 325 milliseconds will take the unit out of test mode and back to normal operation.

Repeating steps 1 through 4 will force the outputs to alternate between their logic “1” and “0” states.

Testing Sinking Output DuraCoders

If the unit does not have internal pull up resistors, external pull up resistors or equivalent loads are required when testing sinking outputs. If this load is not present, a voltmeter may read that the output is active when it is in its inactive, high impedance, state due to leakage current through the output.

NOTE  When the unit has internal pull up resistors, the voltage on the outputs will be equal to +Vdc. When external pull up resistors are used, the pull up voltage on those resistors does not have to be the same as +Vdc. For example, the DuraCoder can be powered by 24 Vdc, while the pull up resistors have 12 Vdc, or 5 Vdc, as their supply voltage. For simplicity in the explanations that follow, “+Vdc” will be used to describe the voltage on the pull up resistors.

High True Output Units

High True output units have the output at 0 Vdc for a logic “0” and +Vdc for a logic “1”.

- ▶ If the Test Pin is pulled low when power is applied to the unit, all outputs are set to 0 Vdc. The drivers are conducting and this is considered a logic “0”.
- 1) If the Test Pin is high or open during power up, the first time it is pulled low for greater than 325 milliseconds, all outputs are set to the +Vdc voltage. The drivers are not conducting and this is considered a logic “1”. If the output voltage is at 0 Vdc, you have a short to ground or a wiring error.
 - 2) Releasing the Test Input for more than 325 milliseconds will take the unit out of test mode and back to normal operation.
 - 3) Pulling the Test Input low for greater than 325 milliseconds will place the unit back into test mode. All of the outputs are now set to 0 Vdc. The drivers are conducting and this is considered a logic “0”. If the output voltage is at +Vdc, you have a short to +Vdc or a wiring error.
 - 4) Releasing the Test Input for more than 325 milliseconds will take the unit out of test mode and back to normal operation.
- Repeating steps 1 through 4 will force the outputs to alternate between their logic “1” and “0” states.

Low True Output Units

Low True output units have the output at 0 Vdc for a logic “1” and +Vdc for a logic “0”.

- ▶ If the Test Pin is pulled low when power is applied to the unit, all outputs are set to the +Vdc voltage. The drivers are not conducting and this is considered a logic “0”.
- 1) If the Test Pin is high or open during power up, the first time it is pulled low for greater than 325 milliseconds, all outputs are set to 0 Vdc. The drivers are conducting and this is considered a logic “1”. If the output voltage is at +Vdc, you have a short to +Vdc or a wiring error.
 - 2) Releasing the Test Input for more than 325 milliseconds will take the unit out of test mode and back to normal operation.
 - 3) Pulling the Test Input low for greater than 325 milliseconds will place the unit back into test mode. All of the outputs are now set to the +Vdc voltage. The drivers are not conducting and this is considered a logic “0”. If the output voltage is at 0 Vdc, you have a short to ground or a wiring error.
 - 4) Releasing the Test Input for more than 325 milliseconds will take the unit out of test mode and back to normal operation.
- Repeating steps 1 through 4 will force the outputs to alternate between their logic “1” and “0” states.

Notes



ADVANCED MICRO CONTROLS INC.

20 GEAR DRIVE, TERRYVILLE, CT 06786 T: (860) 585-1254 F: (860) 584-1973

www.amci.com

LEADERS IN ADVANCED CONTROL PRODUCTS