

DC25

Incremental DuraCoder

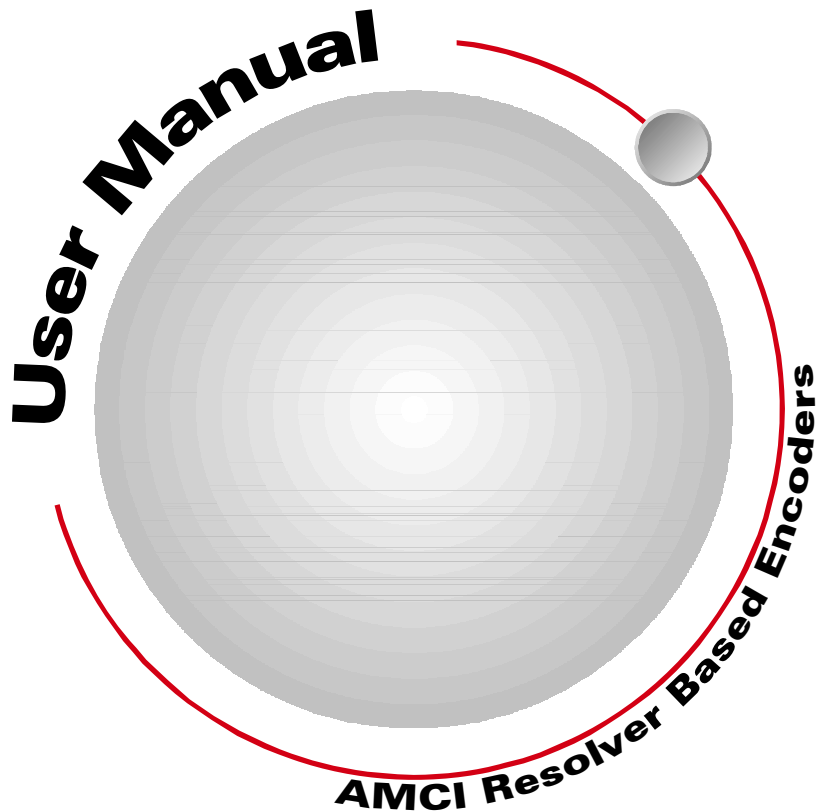

GENERAL INFORMATION

Important User Information

The products and application data described in this manual are useful in a wide variety of different applications. Therefore, the user and others responsible for applying these products described herein are responsible for determining the acceptability for each application. While efforts have been made to provide accurate information within this manual, AMCI assumes no responsibility for the application or the completeness of the information contained herein.

UNDER NO CIRCUMSTANCES WILL ADVANCED MICRO CONTROLS, INC. BE RESPONSIBLE OR LIABLE FOR ANY DAMAGES OR LOSSES, INCLUDING INDIRECT OR CONSEQUENTIAL DAMAGES OR LOSSES, ARISING FROM THE USE OF ANY INFORMATION CONTAINED WITHIN THIS MANUAL, OR THE USE OF ANY PRODUCTS OR SERVICES REFERENCED HEREIN.

No patent liability is assumed by AMCI, with respect to use of information, circuits, equipment, or software described in this manual.

The information contained within this manual is subject to change without notice.

This manual is copyright 2010 by Advanced Micro Controls Inc. You may reproduce this manual, in whole or in part, for your personal use, provided that this copyright notice is included. You may distribute copies of this complete manual in electronic format provided that they are unaltered from the version posted by Advanced Micro Controls Inc. on our official website: www.amci.com. You may incorporate portions of this documents in other literature for your own personal use provided that you include the notice "Portions of this document copyright 2010 by Advanced Micro Controls Inc." You may not alter the contents of this document or charge a fee for reproducing or distributing it.

Standard Warranty

ADVANCED MICRO CONTROLS, INC. warrants that all equipment manufactured by it will be free from defects, under normal use, in materials and workmanship for a period of [18] months. Within this warranty period, AMCI shall, at its option, repair or replace, free of charge, any equipment covered by this warranty which is returned, shipping charges prepaid, within eighteen months from date of invoice, and which upon examination proves to be defective in material or workmanship and not caused by accident, misuse, neglect, alteration, improper installation or improper testing.

The provisions of the "STANDARD WARRANTY" are the sole obligations of AMCI and excludes all other warranties expressed or implied. In no event shall AMCI be liable for incidental or consequential damages or for delay in performance of this warranty.

Returns Policy

All equipment being returned to AMCI for repair or replacement, regardless of warranty status, must have a Return Merchandise Authorization number issued by AMCI. Call (860) 585-1254 with the model number and serial number (if applicable) along with a description of the problem. A "RMA" number will be issued. Equipment must be shipped to AMCI with transportation charges prepaid. Title and risk of loss or damage remains with the customer until shipment is received by AMCI.

24 Hour Technical Support Number

24 Hour technical support is available on this product. If you have internet access, start at www.amci.com. Product documentation and FAQ's are available on the site that answer most common questions.

If you require additional technical support, call (860) 583-7271. Your call will be answered by the factory during regular business hours, Monday through Friday, 8AM - 5PM Eastern. During non-business hours an automated system will ask you to enter the telephone number you can be reached at. Please remember to include your area code. The system will page an engineer on call. Please have your product model number and a description of the problem ready before you call.

We Want Your Feedback

Manuals at AMCI are constantly evolving entities. Your questions and comments on this manual are both welcomed and necessary if this manual is to be improved. Please direct all comments to: Technical Documentation, AMCI, 20 Gear Drive, Terryville CT 06786, or fax us at (860) 584-1973. You can also e-mail your questions and comments to techsupport@amci.com

TABLE OF CONTENTS

General Information

Important User Information	2
Standard Warranty	2
Returns Policy	2
24 Hour Technical Support Number	2
We Want Your Feedback	2

About This Manual

Audience	5
Navigating this Manual	5
Manual Conventions	5
Trademarks and Other Legal Stuff	5
Revision Record	6
Where to Go From Here	6

Chapter 1: The Incremental DuraCoder

Incremental DuraCoder Overview	7
Part Numbering System	8
Output Configurations	8
Electrical Specifications	9
Environmental Specifications	9
Mechanical Specifications	9

Chapter 2: Installation

Setting Counts Per Turn	11
Required Tools	11
Removing the Rear Cover	11
Setting Switches	12
Replacing the Rear Cover	12
Flange Mount Outline Drawings	13
Aluminum Body, End Connector	13
Aluminum Body, Side Connector	13
316 Stainless Steel Body, Side Connector	14
Alternate Shafts	14
Shaft Loading	14

Chapter 2: Installation

Servo Mount Outline Drawings	15
Aluminum Body, End Connector	15
Aluminum Body, Side Connector	15
316 Stainless Steel Body, Side Connector	16
Alternate Shafts	16
Shaft Loading	16
Blind Shaft Mount Outline Drawings	17
Aluminum Body, End Connector	17
Aluminum Body, Side Connector	18
316 Stainless Steel Body, Side Connector	19
Available Shaft Diameters	19
Shaft Loading	19
5/8" Shaft Outline Drawings	20
Aluminum Body, End Connector	20
Aluminum Body, Side Connector	21
316 Stainless Steel, Side Connector	22
Shaft Loading	23
Connector Pinouts	23
Single Ended Output Connector, Aluminum Body	23
Differential Output Connector, Aluminum Body	24
M12 Stainless Steel Output Connector	24
Cables	25
CDCNS-(x) Cable for Single Ended Output DuraCoder	25
CDCND-(x) Cable for Differential Output DuraCoder	25

Notes:

ABOUT THIS MANUAL

Read this chapter to learn how to navigate through this manual and familiarize yourself with the conventions used in it. The last section of this chapter highlights the manual's remaining chapters and their target audience.

Audience

This manual explains the installation and operation of incremental output DuraCoders from AMCI. It is written for the engineer responsible for incorporating the Incremental DuraCoder into a design as well as the engineer or technician responsible for its actual installation. If there are any unanswered questions after reading this manual, call the factory. An applications engineer will be available to assist you.

Navigating this Manual

This manual is designed to be used in both printed and on-line forms. Its on-line form is a PDF document, which requires Adobe Acrobat Reader version 4.0+ to open it.

Bookmarks of all the chapter names, section headings, and sub-headings are in the PDF file to help you navigate through it. The bookmarks should have appeared when you opened the file. If they didn't, press the F5 key on Windows platforms to bring them up.

Throughout this manual you will also find *blue text that functions as a hyperlink* in HTML documents. Clicking on the text will immediately jump you to the referenced section of the manual. If you are reading a printed manual, most links include page numbers.

The PDF file is password protected to prevent changes to the document. You are allowed to select and copy sections for use in other documents and, if you own Adobe Acrobat version 4.05 or later, you are allowed to add notes and annotations.

Manual Conventions

Three icons are used to highlight important information in the manual:



NOTES highlight important concepts, decisions you must make, or the implications of those decisions.



CAUTIONS tell you when equipment may be damaged if the procedure is not followed properly.



WARNINGS tell you when people may be hurt or equipment may be damaged if the procedure is not followed properly.

The following table shows the text formatting conventions:

Format	Description
Normal Font	Font used throughout this manual.
<i>Emphasis Font</i>	Font used the first time a new term is introduced.
<i>Cross Reference</i>	When viewing the PDF version of the manual, clicking on the cross reference text jumps you to referenced section.

Trademarks and Other Legal Stuff

The AMCI logo is a trademark, and "AMCI" and "DuraCoder" are registered trademarks of Advanced Micro Controls Inc. "Adobe" and "acrobat" are registered trademarks of Adobe Systems Incorporated.

All other trademarks contained herein are the property of their respective holders.

Revision Record

This manual, 940-0D015 is the fifth release of the manual. It changes the format of the manual and specifies new shaft and mounting options. It was first released January 27, 2010.

Where to Go From Here

The table below gives a brief description of the content of each chapter to help you find the information you need to assist you in your job.

CHP NUM.	Chapter Title	Chapter Description
1	<i>THE INCREMENTAL DURACODER</i>	Intended for anyone new to the Incremental DuraCoder, this chapter gives a basic overview of the unit. The chapter also explains the Incremental DuraCoder part numbering system.
2	<i>INSTALLATION</i>	This chapter is intended for the engineer or technician responsible for installing and wiring the Incremental DuraCoder. Information in this chapter includes mechanical drawings, installation guidelines and connector pinout.

THE INCREMENTAL DURACODER

Incremental DuraCoder Overview

Simply put, DuraCoders are designed to be the most durable encoders on the market today. Instead of being designed around a disk and optics like an optical encoder, each DuraCoder uses a resolver as its primary shaft position sensor. The resolver is an analog device whose outputs vary sinusoidally as the shaft is rotated. Constructed in a manner similar to high precision motors, resolvers are absolute, single turn position sensors that are unsurpassed in terms of ruggedness and reliability.

Originally designed for military applications over 60 years ago, resolvers have gained popularity in many industrial markets from steel mills to packaging machines. If you are interested in learning more about resolvers, check out our website at:

<http://www.amci.com/tutorials/tutorials-what-is-resolver.asp>.

The resolver's analog signals are decoded into a 12 bit position value by industrial grade electronics incorporated into the DuraCoder. From there, the electronics of the DuraCoder generate the familiar quadrature pulse train of a standard incremental encoder. The DuraCoder also generates a marker pulse, or Z pulse, when the resolver passes through its electrical zero position.

There are three different Incremental DuraCoder types. A type 'N' DuraCoder is our standard product, offering a maximum position resolution of 4,096 counts per turn. This type of DuraCoder generates 1,024 quadrature cycles and a single, gated, marker pulse. You must use 4X decoding to retrieve these 4,096 counts.

The type 'N' DuraCoder uses what is known as a *1-Speed* resolver. This means that the resolver completes one sinusoidal cycle per rotation of the DuraCoder shaft. The other two types of Incremental DuraCoders available for AMCI use either a *2-Speed* or *4-Speed* resolver, which completes two or four sinusoidal cycles per rotation of the DuraCoder shaft. The type 'T' DuraCoder contain a 2-Speed resolver and offers a maximum of 2,048 quadrature cycles, or 8,192 counts, per turn. The Type 'F' DuraCoder contain a 4-Speed resolver and offers a maximum of 4,096 quadrature cycles, or 16,384 counts, per turn.

The only drawback to the 'T' and 'F' type DuraCoders is the number of marker pulses they generate. Because the resolver passes through its zero position two or four times per rotation, the DuraCoder generates two or four marker pulses. If you are considering using either of these types of DuraCoders, verify that the additional marker pulses will not affect your control system.

Incremental DuraCoders are available with differential or single ended outputs. Differential outputs are 5Vdc outputs only. Single ended outputs are available as sinking or sourcing outputs with or without pull up resistors.

Finally, the Incremental DuraCoder is available in a variety of industry standard size 25 optical encoder packages. A flange mount unit with a 3/8" shaft and a side connector is shown on the right side of figure 1.1. The DuraCoder on the left of the figure is with a 5/8" shaft and it is designed for applications that may be exposed to high shaft loads. Servo mount units are also available. If your application requires you to mount the DuraCoder to a motor, a blind shaft mounting option is available as well. All four mounting styles are also available with connectors coming out the end of the unit instead of the side.

In addition to our standard IP67 DuraCoders with powder-coated aluminum bodies, Incremental DuraCoders are also available in 316 stainless steel for use in food grade, marine, or corrosive environments.

Outline drawings of all of the packing options is available in the *Outline Drawings* section of the ***INSTALLATION*** chapter, starting on page 13.



Figure 1.1 Incremental DuraCoders



Electrical Specifications

Operating Voltage

4.75Vdc to 26.4Vdc

Power Requirements

1.5 W max.
60mA @ 24Vdc

Code Format

2 square waves in quadrature with gated index.

Cycles per Turn

Type N (1-Speed resolver):
2 to 1024, 1 marker (Z) pulse per rotation

Type T (2-Speed resolver):
4 to 2048, multiples of 2 only.
2 marker (Z) pulses per rotation

Type F (4-Speed resolver):
8 to 4096, multiples of 4 only.
4 marker (Z) pulses per rotation

Cycles per turn can be factory set or field programmable.

Frequency Response

Data: 210 kHz min.
Index: 125 kHz min.

Direction of Increasing Counts (A Leads B)

CW looking at shaft

Output Types

Differential., Open Collector Sourcing, Open Collector Sinking, Sourcing with 2.2K Ω pull-down resistor, and Sinking with 2.2K Ω pull-up resistor.

On State Current

Differential: 20mA maximum
Single Ended: 50mA maximum

Leakage Current

Single Ended: 300 microamps maximum

Environmental Specifications

Operating Temperature

-40°F to +185°F (-40°C to +85°C)

Shock

50g, 11 millisecond duration

Vibration

20g, 5 to 2000Hz

Enclosure Rating

IP67

Approximate Weight

2.0 lbs. (0.91 kg) 0.625" shafts - Aluminum Body
3.9 lbs. (1.77 kg) 0.625" shafts - 316 Steel Body
1.4 lbs. (0.65 kg) All other shafts - Aluminum Body
2.9 lbs. (1.32 kg) All other shafts - 316 Steel Body

Mechanical Specifications

Package Style

2.5 inch housing with flange, servo, or blind shaft mounting

Connector Location

Side or End

Housing

Powder coated aluminum or 316 stainless steel

Shaft

0.250", 0.375", 0.625", or 10mm

Blind Shaft with 0.375", 0.500", 10mm or 12 mm hole

Max. Starting Torque @ 25°C

2.0 oz-in: 0.250", 0.375", and 10mm shafts
6.0 oz-in: All blind shafts
6.0 oz-in: 0.625" shaft

Moment of Inertia (oz-in-sec²)

6.00 X 10⁻⁴: 0.250", 0.375", and 10mm shafts
7.00 X 10⁻⁴: All blind shafts
8.50 X 10⁻⁴: 0.625" shaft

Max. Operating Speed

6000 RPM

Max. Shaft Loading (0.625" shaft)

Axial: 50 lbs. (222 N)
Radial: 100 lbs. (445 N)
At the specified maximum loads, the average minimum bearing life is 2X10⁹ revolutions.

Max. Shaft Loading (All other shafts)

Axial: 20 lbs. (89 N)
Radial: 40 lbs. (178 N)
At the specified maximum loads, the average minimum bearing life is 2X10⁹ revolutions.



Notes

CHAPTER 2

INSTALLATION

Setting Counts Per Turn

Most DuraCoders are ordered with the number of counts per turn set during assembly at AMCI. However, if your factory or application uses multiple DuraCoders with different counts per turn settings, it is possible to order a DuraCoder that is field programmable. Ordering a DuraCoder this way allow you to reduce the number of spares you need to stock.

DuraCoders with the following part numbers are field programmable:

➤ **DC25?-???PRGM??**

“?” characters are “Don’t Care” terms and can be any value.

The procedure involves removing the back cover, Setting the DIP switches, and putting the cover back on.

Required Tools

A clean, static-free work space, a #0 phillips head screwdriver, a utility knife, a small flat head screwdriver, and tweezers.



This procedure must be done in a clean, static free environment. Failure to follow this caution may result in immediate damage to the electronics or a failure of the IP67 seal that could result in liquids entering the DuraCoder during operation.

Removing the Rear Cover

The first step in removing the rear cover is to remove the three black screws that hold the rear cover to the body. A #0 philips head screwdriver is recommended for removing the screws.



Each screw has a small o-ring under its head. These o-rings are important in maintaining the DuraCoder’s IP67 rating. Place the screws in a clean area when disassembling the DuraCoder to prevent dirt and other debris from affecting the o-rings.

Once the screws are removed, you can *gently* remove the rear cover. If you have an end connect DuraCoder, take a good look at figure 2.1 before proceeding. The two most important things to note are the o-ring in the rear cover and the short length of the wires from the connector to the DuraCoder electronics. You do not want to damage either of these as you remove the cover. Even if you have side connect DuraCoder, (see Figure 1.1 on page 7) you must use care to avoid damaging the o-ring seal on the cover.

You may need to use a utility knife to start separating the cover from the body, but a thumbnail can be used with a little practice. Once a gap between the cover and the body has been opened, you can use a small flathead screwdriver to finish removing the cover. Work around the perimeter of the cover while gently prying it off. Use care to avoid damaging the o-ring seal.



Figure 2.1 DuraCoder with Cover Removed

Setting Cycles Per Turn (continued)

Setting Switches

Figure 2.2 shows the location of the DIP switches on the DuraCoder. (These switches are also visible in figure 2.1.) You will also see two header blocks that may have jumpers on them. These jumpers are set at the factory and must not be changed.

There is a protective tape over the switches which can be easily removed with a pair of tweezers. This tape should be put back on the switches when you are done setting the number of cycles per turn.

The DIP switches are used to set the binary number that is equal to (Cycles per Turn) – 1. Setting a switch ON sets a logic 0 and setting a switch OFF sets a logic 1. The binary number set by the DIP switches is always between 1 and 1,023. A value of zero is not allowed.

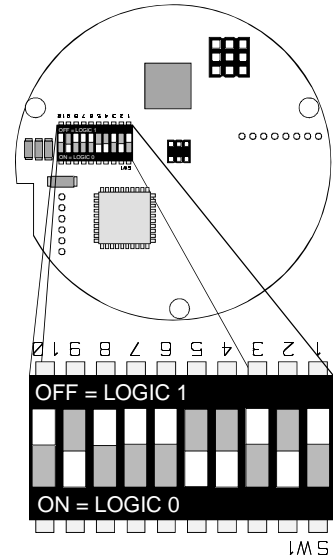

Figure 2.2 DIP Switch Locations

NOTE

Check your DuraCoder Type. (DC25?-??XPRGM??). If your DuraCoder is type 'N', you can ignore the rest of this note.

If your DuraCoder is type T: Your DuraCoder has a 2-Speed resolver in it. You must set the DIP switches to ((Cycles per Turn/2) – 1). The actual number of cycles per turn output by the DuraCoder will be an even number between 4 and 2,048. Your DuraCoder will also output two Z pulses spaced 180° apart.

If your DuraCoder is type F: Your DuraCoder has a 4-Speed resolver in it. You must set the DIP switches to ((Cycles per Turn/4) – 1). The actual number of cycles per turn output by the DuraCoder will be an even number between 8 and 4,096. Your DuraCoder will also output four Z pulses spaced 90° apart.

If you don't have a calculator to perform the decimal to binary conversion, use the table below to determine which switches should be OFF. Start with your "(Cycles per Turn)-1" value and subtract the largest possible number from the table. Set the corresponding switch OFF. Continue subtracting the next largest possible number from the remaining value and turning the corresponding switch OFF until you have a remainder of zero.

For example, assume you want 742 Cycles per Turn. The jumpers must be set to equal 741.

741 - 512 = 229 (SW10 OFF)
 229 - 128 = 101 (SW8 OFF)
 101 - 64 = 37 (SW7 OFF)
 37 - 32 = 5 (SW6 OFF)
 5 - 4 = 1 (SW3 OFF)
 1 - 1 = 0 (SW1 OFF)
 Switches 9,5, 4, and 2 are set ON.

SW.#	Weight	SW.#	Weight
10	512	5	16
9	256	4	8
8	128	3	4
7	64	2	2
6	32	1	1

Table 2.1 Jumper Weight

Replacing the Rear Cover

Replacing the rear cover is fairly easy. Simply set the rear cover on the back of the DuraCoder and rotate it until the screw holes line up with the standoffs that hold the PC board in place. If the DuraCoder has an end connector, make sure the wires are not wound too tightly or pinched between a standoff and the cover. Grasp the DuraCoder with your fingers holding the front of the unit and your thumbs on the rear cover. Once you are sure the o-ring in the rear cover is not pinched, press the rear cover into place with your thumbs. Rotate the rear cover as needed to align the holes with the standoffs and install the three rear cover screws. The screws should be tightened firmly, but not over tightened as this may damage the o-rings in their heads.

Flange Mount Outline Drawings

Aluminum Body, End Connector

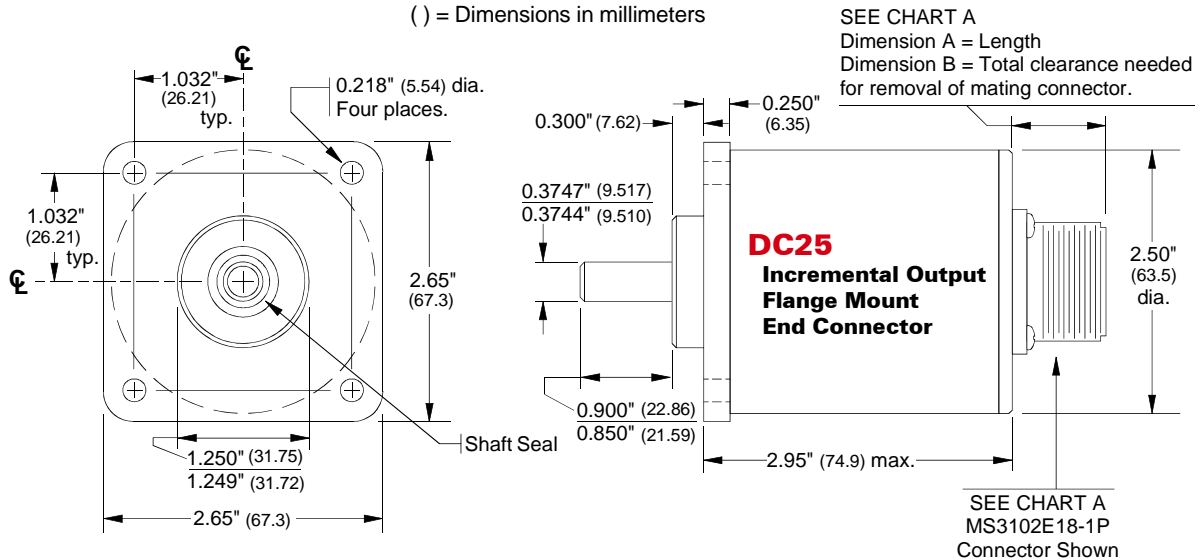

CHART A

Output Type	Connector	Dim. A	Dim. B
Differential	MS3102E18-1P	0.94" (23.9) max.	4.5" (114)
All Other	MS3102E16S-1P	0.70" (17.8) max.	3.5" (89)

Figure 2.3 Aluminum Body, Flange Mount, End Connect Outline Drawing

Aluminum Body, Side Connector

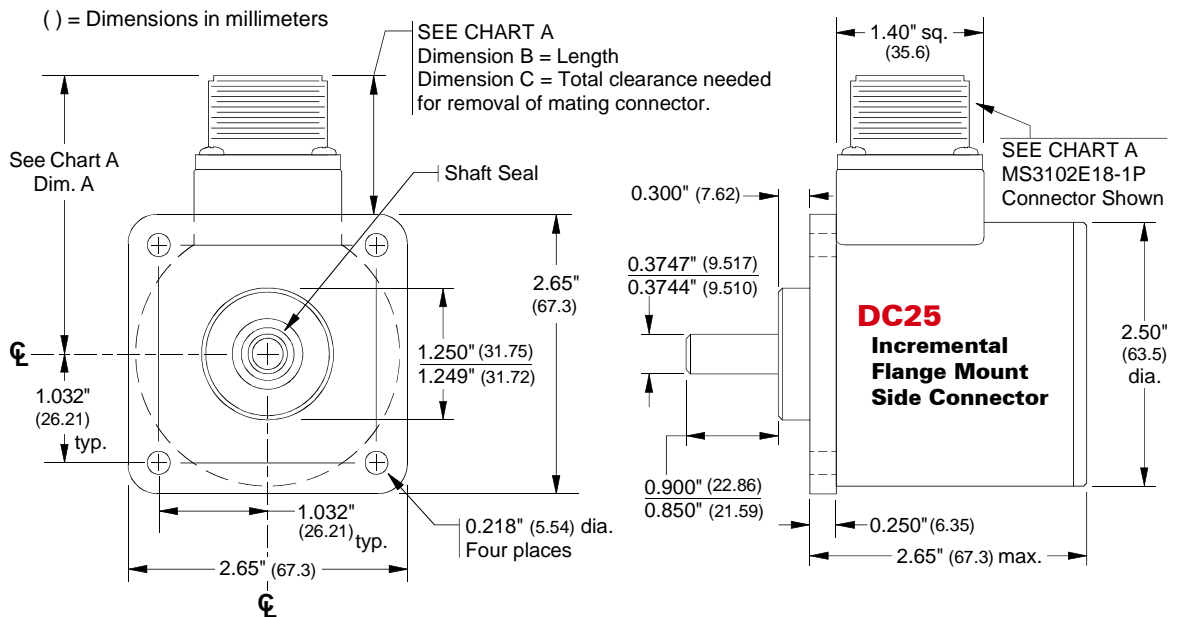

CHART A

Output Type	Connector	Dim. A	Dim. B	Dim. C
Differential	MS3102E18-1P	2.69" (68.3) max.	1.37" (34.8) max.	5.0" (127)
All Other	MS3102E16S-1P	2.45" (62.2) max.	1.13" (28.7) max.	4.0" (102)

Figure 2.4 Aluminum Body, Flange Mount, Side Connect Outline Drawing

Flange Mount Outline Drawings (continued)
316 Stainless Steel Body, Side Connector

Figure 2.5 316 Stainless Steel, Flange Mount, Side Connect Outline Drawing

Alternate Shafts
**10mm Shaft
(Shaft Option 2)**

**1/4" Shaft
(Shaft Option 3)**

() = Dimensions in mm

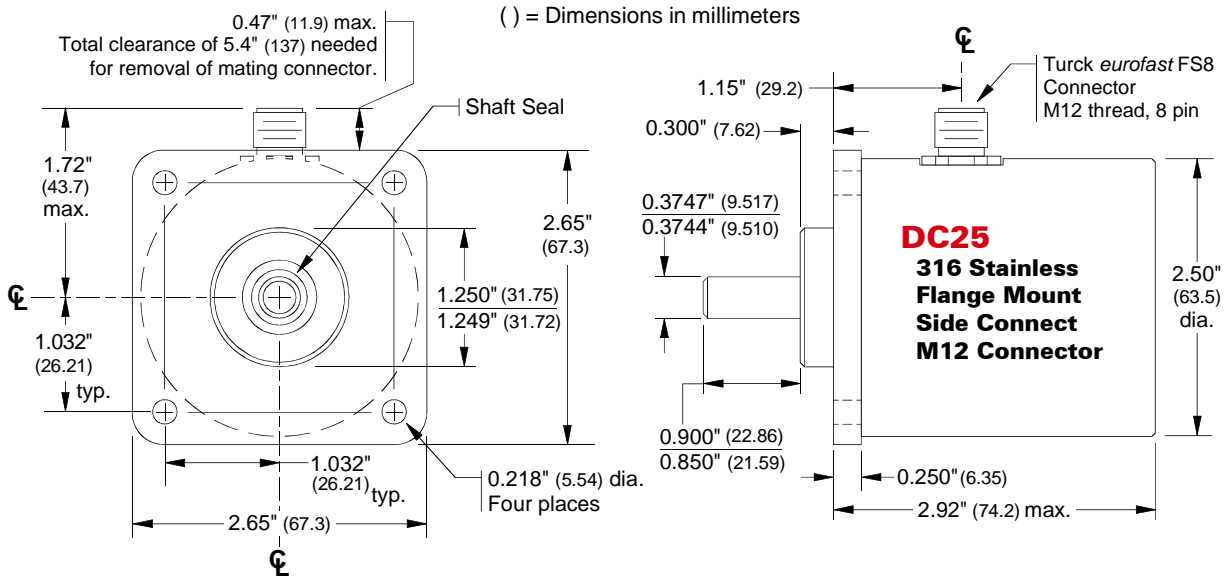
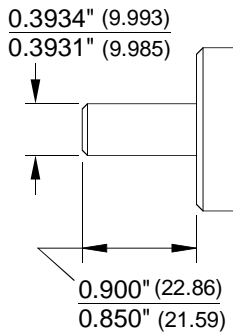
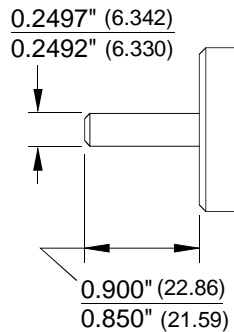
Figure 2.6 Flange Mount Alternate Shafts

Shaft Loading

Limit shaft loading to the following values. These values statistically yield an L10 life of 2×10^9 revolutions. (L10 life is a rating which means that statistically, only 10% of the bearings will have failed after 2×10^9 revolutions.) Shaft loading has an exponential effect on bearing life. The bearings will statistically last longer if you can limit shaft loading below the given values. Consider using the 5/8" shaft DuraCoder from AMCI if your shaft loading is expected to be greater than the values given below. Outline drawings for the 5/8" shaft DuraCoders start on page 20.

Radial Load	Axial Load
40 lbs. (178 N)	20 lbs. (89 N)

Table 2.2 Flange Mount Shaft Loading

Servo Mount Outline Drawings (continued)
316 Stainless Steel Body, Side Connector

Figure 2.9 316 Stainless Steel, Servo Mount, Side Connect Outline Drawing

Alternate Shafts
**10mm Shaft
(Shaft Option 2)**

**1/4" Shaft
(Shaft Option 3)**

() = Dimensions in mm

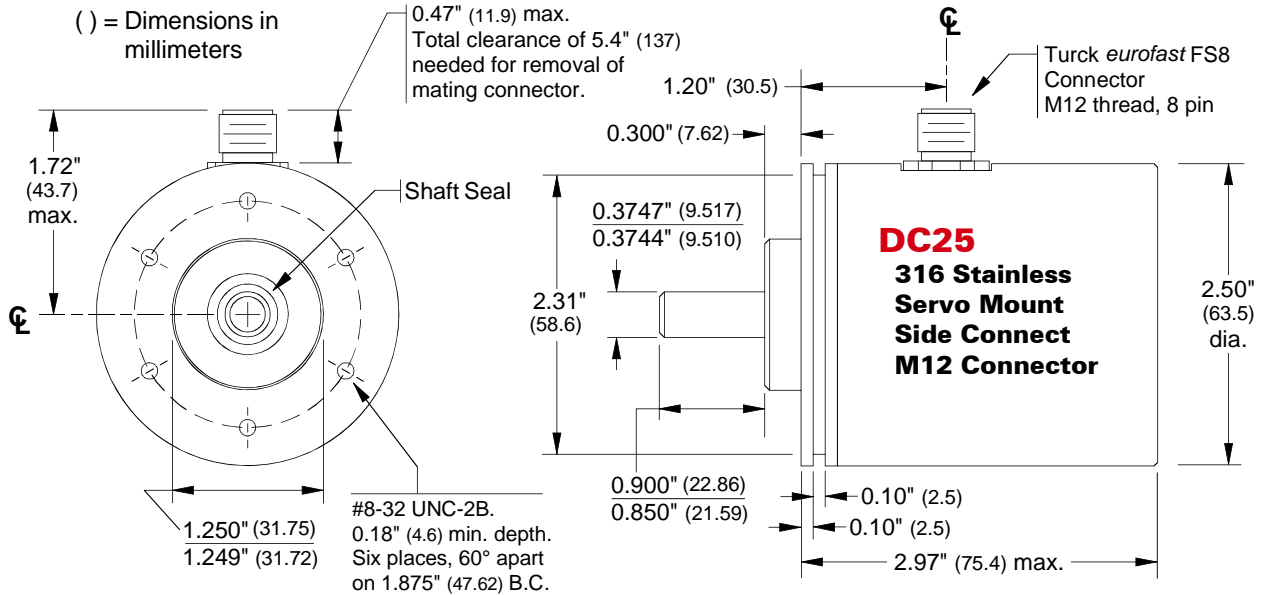
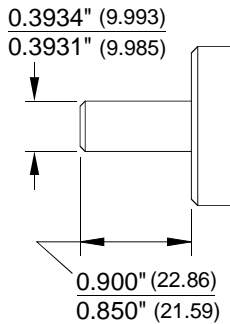
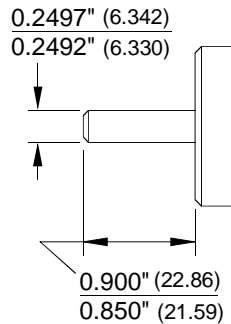
Figure 2.10 Servo Mount Alternate Shafts

Shaft Loading

Limit shaft loading to the following values. These values statistically yield an L10 life of 2×10^9 revolutions. (L10 life is a rating which means that statistically, only 10% of the bearings will have failed after 2×10^9 revolutions.) Shaft loading has an exponential effect on bearing life. The bearings will statistically last longer if you can limit shaft loading below the given values. Consider using the 5/8" shaft DuraCoder from AMCI if your shaft loading is expected to be greater than the values given below. Outline drawings for the 5/8" shaft DuraCoders start on page 20.

Radial Load	Axial Load
40 lbs. (178 N)	20 lbs. (89 N)

Table 2.3 Servo Mount Shaft Loading

Blind Shaft Mount Outline Drawings

Aluminum Body, End Connector

() = Dimensions in millimeters

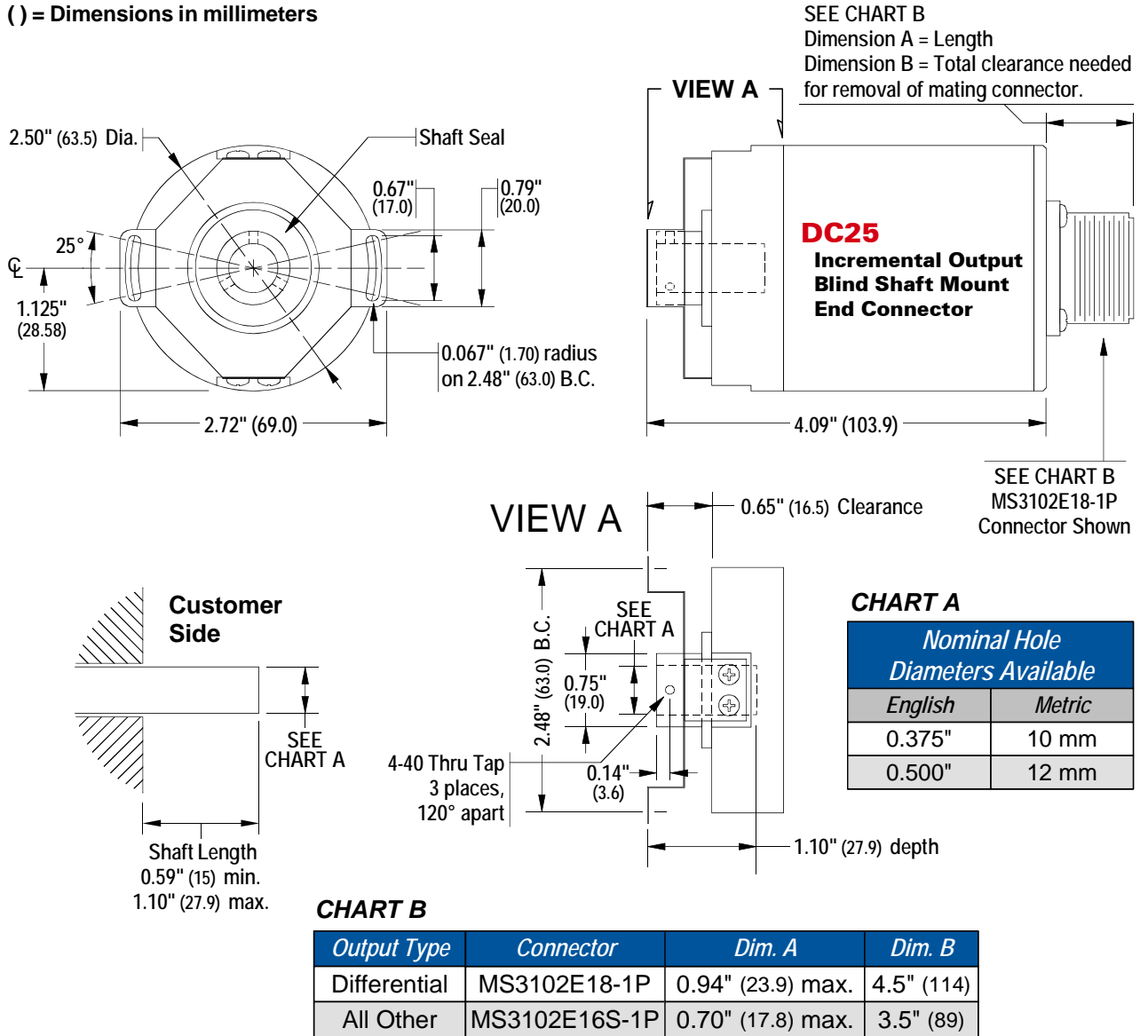
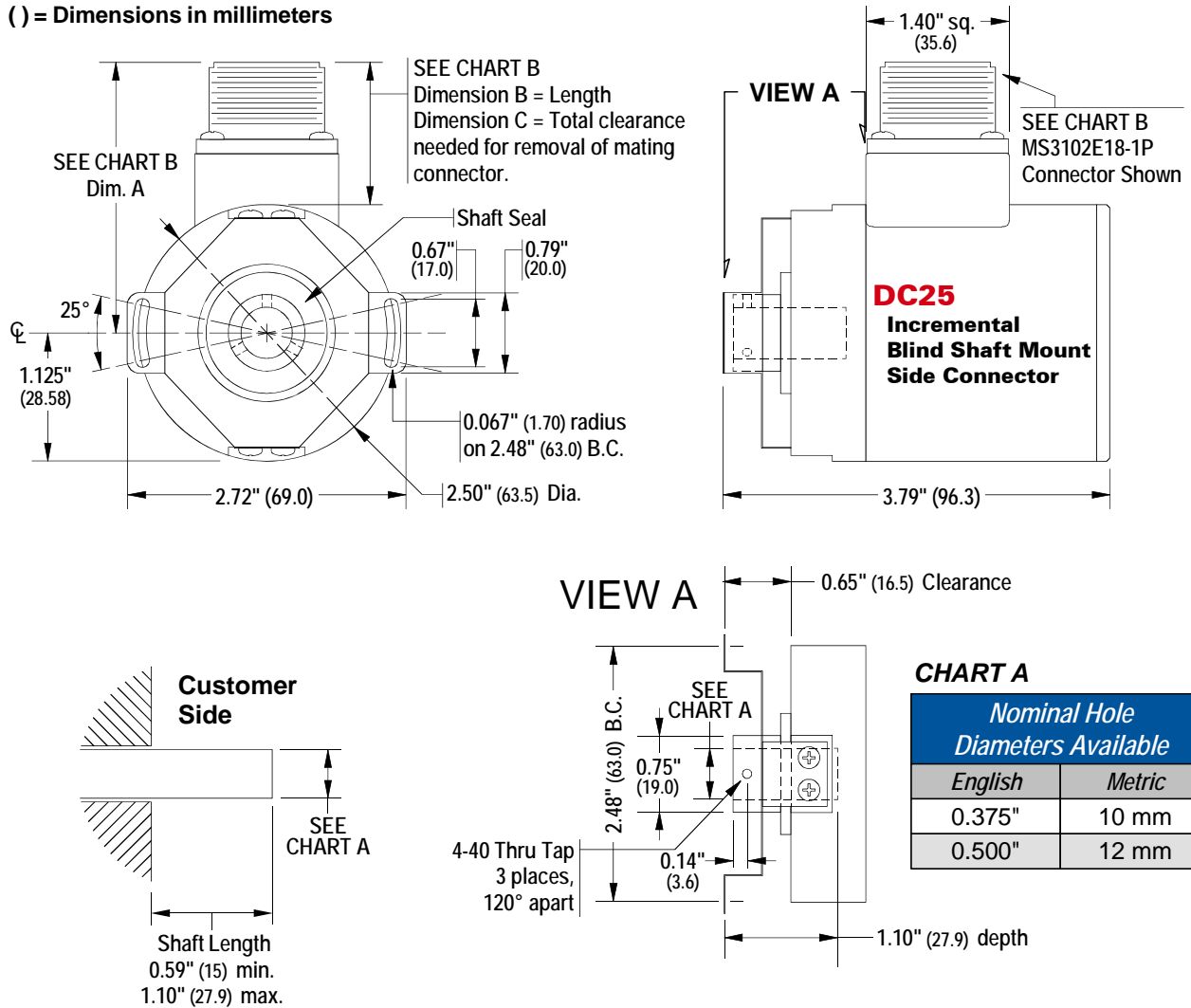

Figure 2.11 Aluminum Body, Blind Shaft Mount, End Connect Outline Drawing

Blind Shaft Mount Outline Drawings (continued)
Aluminum Body, Side Connector

() = Dimensions in millimeters

CHART B

Output Type	Connector	Dim. A	Dim. B	Dim. C
Differential	MS3102E18-1P	2.69" (68.3) max.	1.44" (36.6) max.	5.1" (130)
All Other	MS3102E16S-1P	2.45" (62.2) max.	1.20" (30.5) max.	4.1" (104)

Figure 2.12 Aluminum Body, Blind Shaft Mount, Side Connect Outline Drawing

Blind Shaft Mount Outline Drawings (continued)

316 Stainless Steel Body, Side Connector

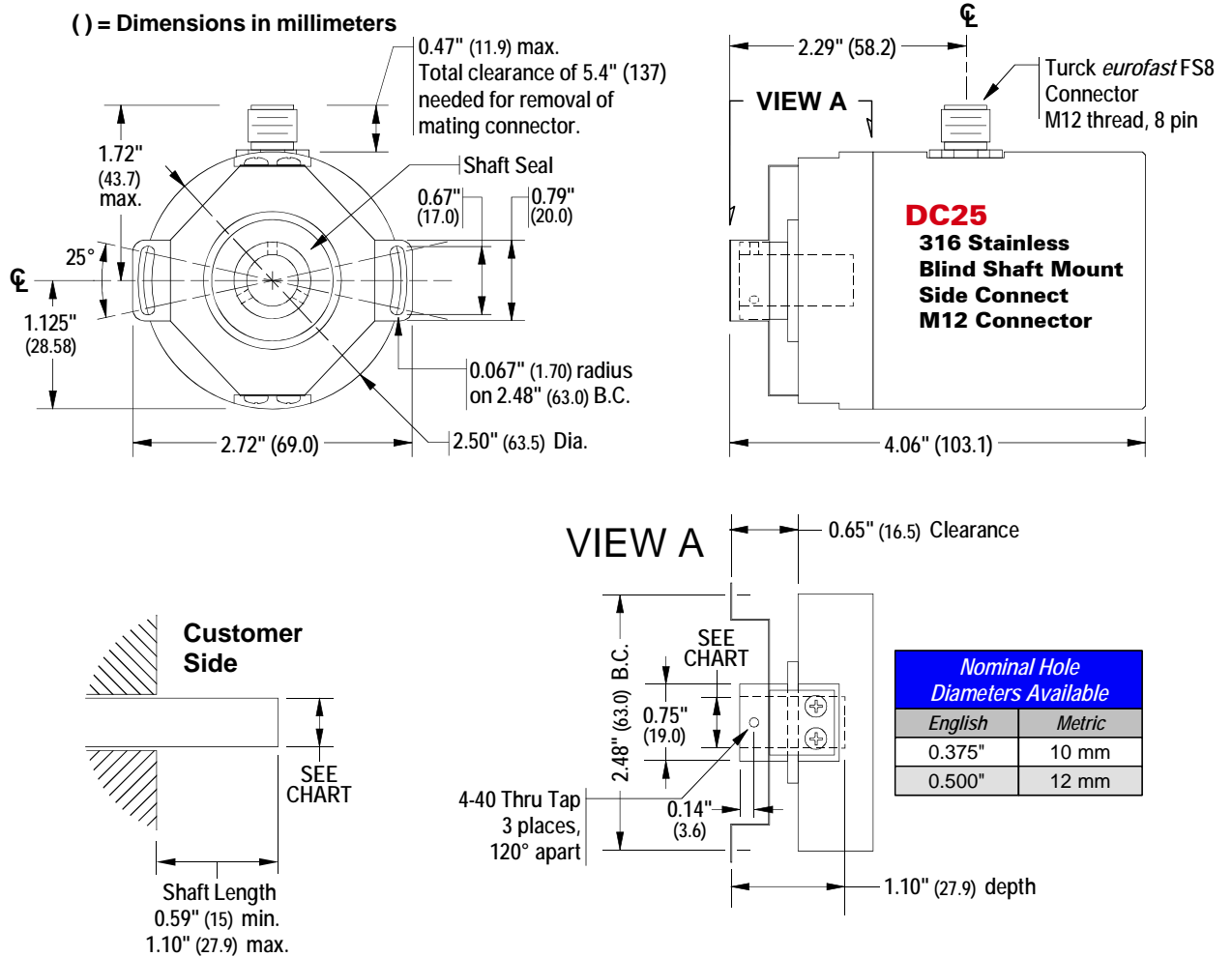

Figure 2.13 316 Stainless Steel Body, Blind Shaft Mount, Side Connect Outline Drawing

Available Shaft Diameters

The diameter of the drive shaft must be specified when ordering a blind shaft DuraCoder. Available options are given in the table below. Other diameter options may have become available after the release of this manual. Please check our website, www.amci.com, if you do not see the shaft diameter that fits your application.

Nominal Hole Diameters	
English	Metric
0.375"	10 mm
0.500"	12 mm

Table 2.4 Available Blind Shaft Diameters

Shaft Loading

The load that the Analog DuraCoder presents to your input shaft, which is equal to the load presented to the DuraCoder by your input shaft, is difficult to calculate and is dependent on the accuracy of the mounting. The flexible metal mounting bracket will be able to absorb most of the radial loading forces, but accurate mounting of the DuraCoder is still important.

5/8" Shaft Outline Drawings
Aluminum Body, End Connector

Figure 2.14 Aluminum Body, 5/8" Shaft, Face Mount, End Connect Outline Drawing

5/8" Shaft Outline Drawings (continued)

Aluminum Body, Side Connector

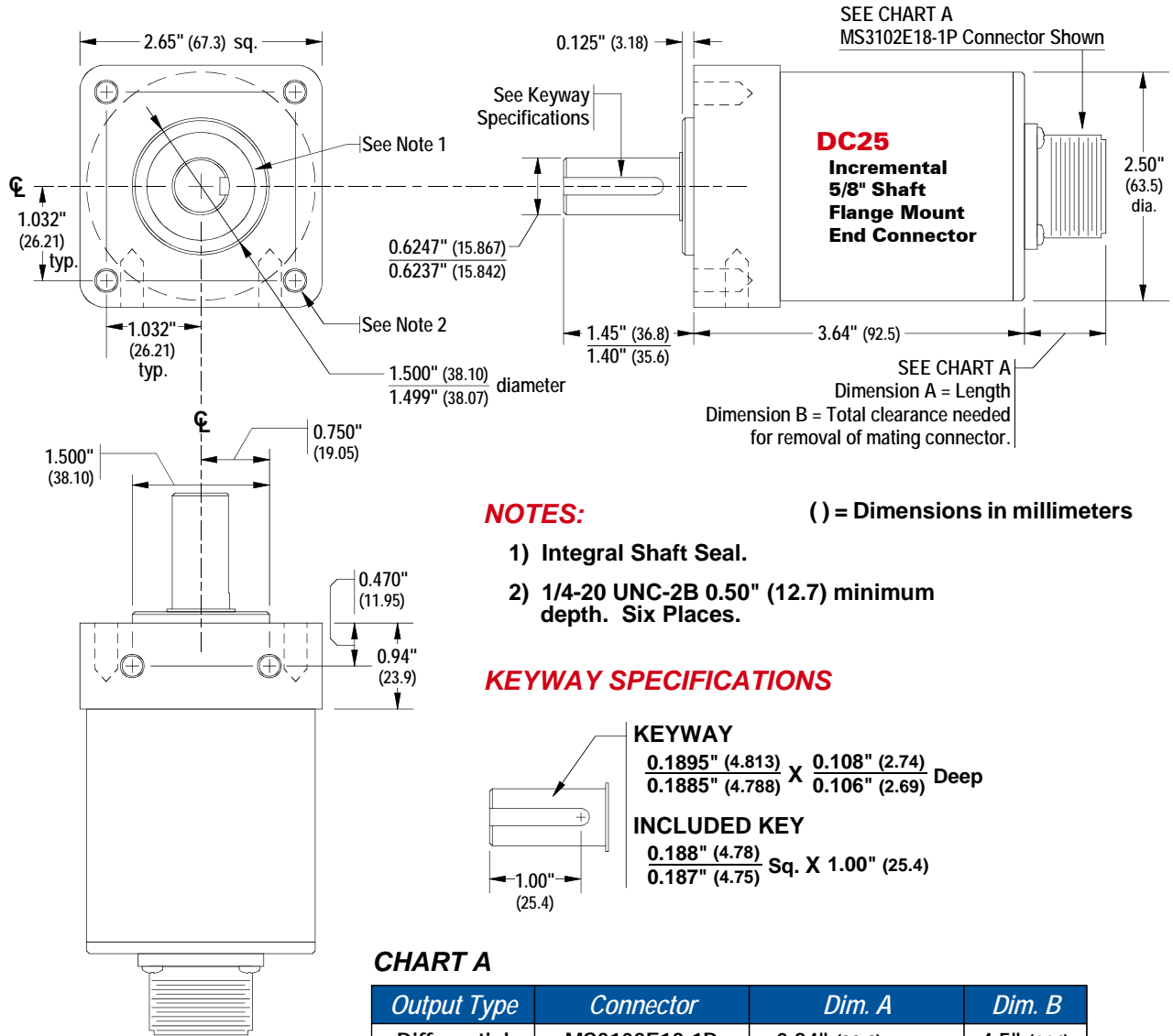
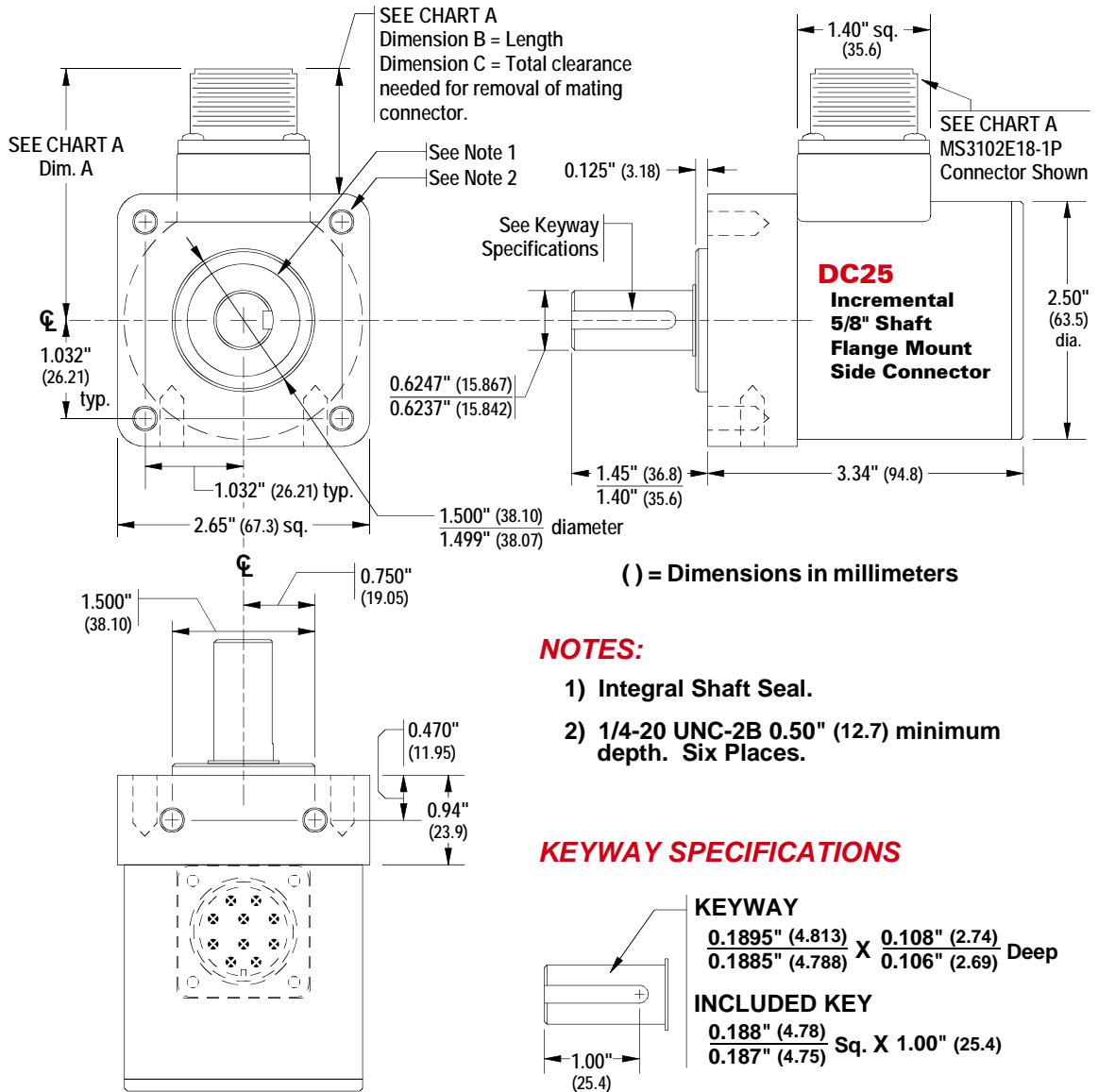

CHART A

Output Type	Connector	Dim. A	Dim. B	Dim. C
Differential	MS3102E18-1P	2.69" (68.3) max.	1.37" (34.8) max.	5.0" (127)
All Other	MS3102E16S-1P	2.45" (62.2) max.	1.13" (28.7) max.	4.0" (102)

Figure 2.15 Aluminum Body, 5/8" Shaft, Face Mount, Side Connect Outline Drawing

5/8" Shaft Outline Drawings (continued)

316 Stainless Steel, Side Connector

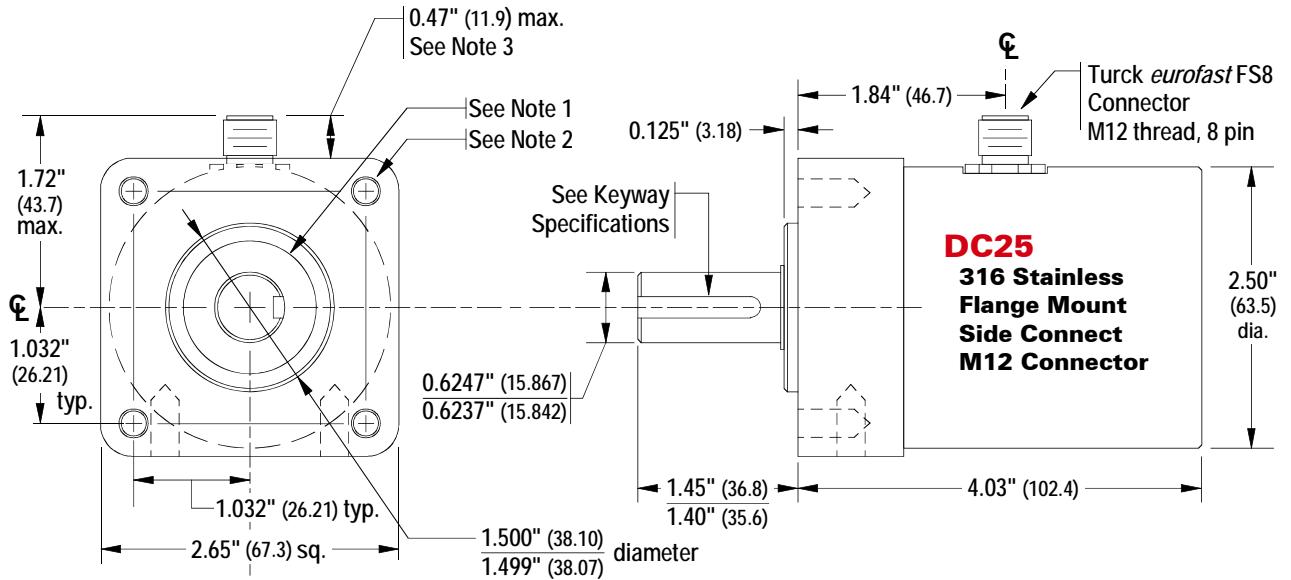

() = Dimensions in millimeters

NOTES:

- 1) Integral Shaft Seal.
- 2) 1/4-20 UNC-2B 0.50" (12.7) minimum depth. Six Places.
- 3) Additional clearance needed for removal of mating connector.

KEYWAY SPECIFICATIONS

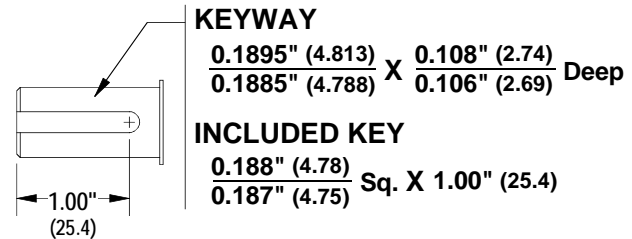

Figure 2.16 316 Stainless Body, 5/8" Shaft, Face Mount, Side Connect Outline Drawing

5/8" Shaft Outline Drawings (continued)

Shaft Loading

Limit shaft loading to the following values. These values statistically yield an L10 life of 2×10^9 revolutions. (L10 life is a rating which means that statistically, only 10% of the bearings will have failed after 2×10^9 revolutions.) Shaft loading has an exponential effect on bearing life. The bearings will statistically last longer if you can limit shaft loading below the given values.

Radial Load	Axial Load
100 lbs. (445 N)	50 lbs. (222 N)

Table 2.5 Flange Mount Shaft Loading

Connector Pinouts

Three different connectors are used with the Incremental DuraCoders, based on the type of outputs and body material.

Single Ended Output Connector, Aluminum Body

DuraCoders with the following part numbers have single ended outputs:

➤ **DC25?-???????(A,B,C,E)?**

“?” characters are “Don’t Care” terms and can be any value.

The parentheses means that the term can be any of the four values.

A: Current Source Outputs, 24Vdc max.

B: Current Sink Outputs, 24Vdc max.

C: Current Sink Outputs with 2.2KΩ pullup to DuraCoder Input Voltage

E: Current Source Outputs with 2.2KΩ pull down resistor.

The connector used by these DuraCoders is the MS3102E16S-1P. The mating connector is sold by AMCI under the AMCI part number MS-16. The pinout for the connector is shown below.

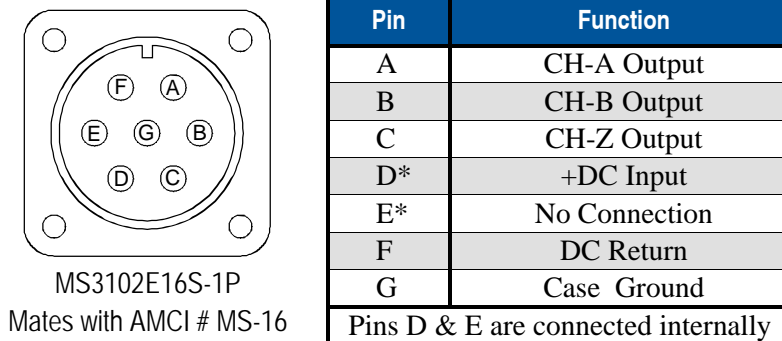

MS3102E16S-1P
Mates with AMCI # MS-16

Figure 2.17 Single Ended Output Connector

Connector Pinouts (continued)

Differential Output Connector, Aluminum Body

DuraCoders with the following part numbers have differential outputs:

➤ **DC25?-??????D?**

“?” characters are “Don’t Care” terms and can be any value.

The connector used by these DuraCoders is the MS3102E18-1P. The mating connector is sold by AMCI under the AMCI part number MSD-10. The pinout for the connector is shown below.

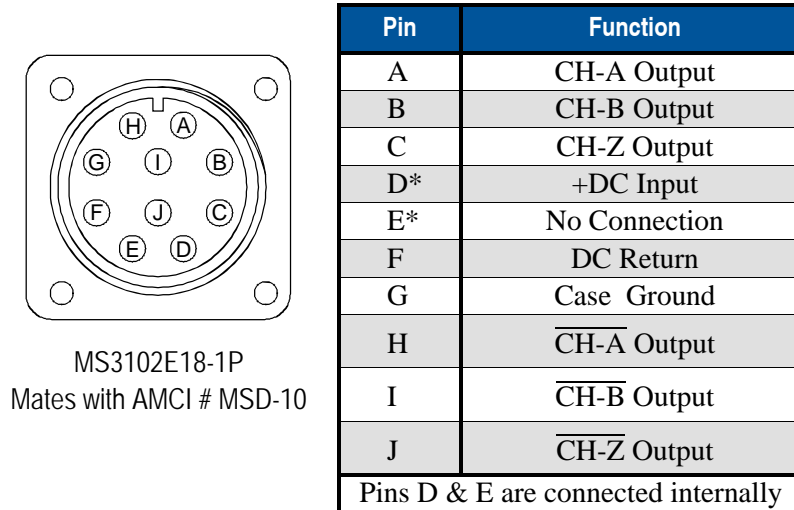
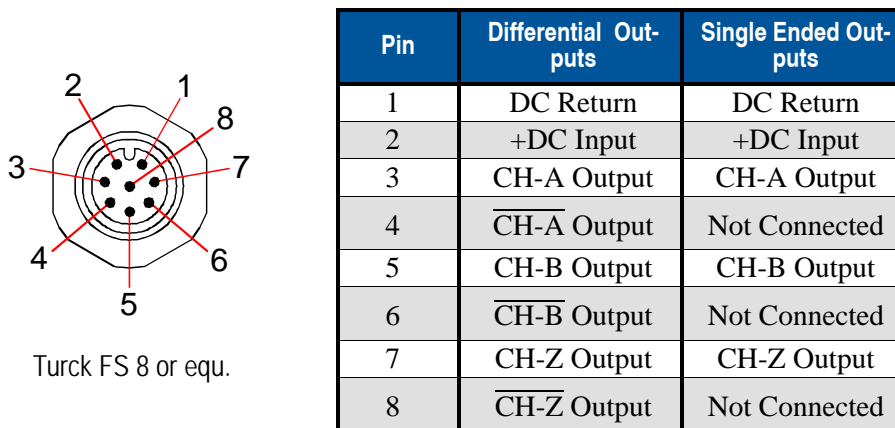

Figure 2.18 Differential Output Connector

M12 Stainless Steel Output Connector

All Incremental DuraCoders with stainless steel bodies use the same eight pin M12 connector. This connector is the Turck *eurofast FS 8* or equivalent. The pinout for the connector is shown below.



Mating connectors and cordsets are available under various part numbers. Contact AMCI for further assistance.

Cables

Two different cables are available from AMCI for the aluminum bodied incremental DuraCoders, based on the type of outputs.

CDCNS-(x) Cable for Single Ended Output DuraCoder

DuraCoders with the following part numbers have single ended outputs:

➤ **DC25?-???????(A,B,C,E)?**

“?” characters are “Don’t Care” terms and can be any value.

The parentheses means that the term can be any of the four values.

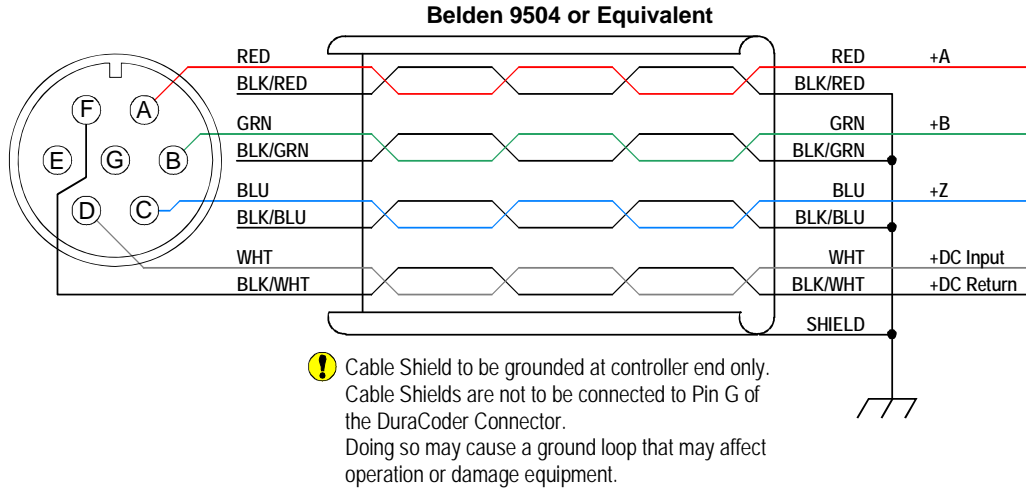

Figure 2.19 CDCNS-(x) Cable

CDCND-(x) Cable for Differential Output DuraCoder

DuraCoders with the following part numbers have differential outputs:

➤ **DC25?-??????D?**

“?” characters are “Don’t Care” terms and can be any value.

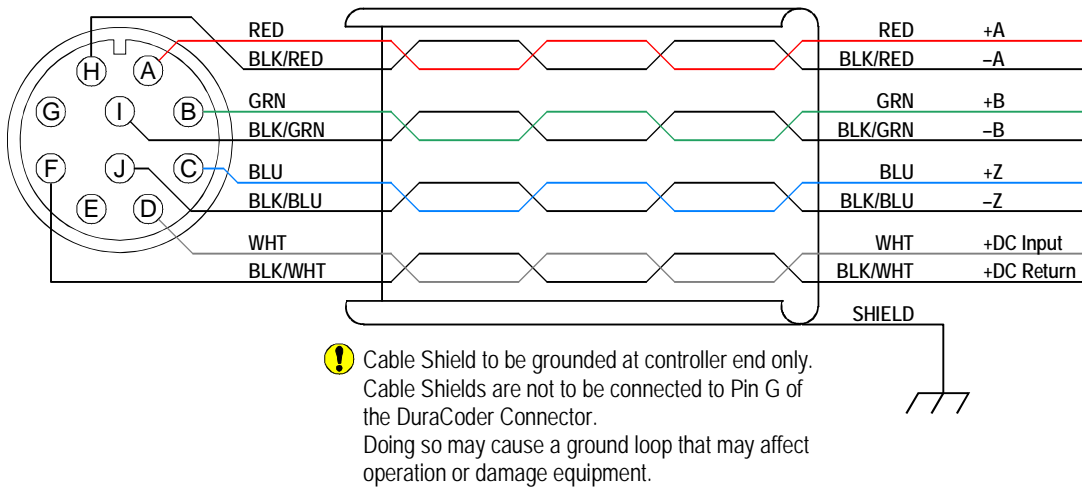

Figure 2.20 CDCND-(x) Cable



ADVANCED MICRO CONTROLS INC.

20 GEAR DRIVE, TERRYVILLE, CT 06786 T: (860) 585-1254 F: (860) 584-1973

www.amci.com

LEADERS IN ADVANCED CONTROL PRODUCTS