

Module Overview

Utilizing licensed GE Fanuc Series 90-30 I/O interface technology, these one slot Resolver Interface Modules accept one or two single resolver transducer inputs and plug directly into GE Fanuc 90-30 rack. Communicating through I/O registers assigned to the slot, these modules supply absolute position and tachometer data to any 90-30 CPU from AMCI resolver based transducers.

This manual explains the installation and operation of the following four modules.

Module	Number of Channels	Maximum Resolution (counts/turn)
1331	1	1024
1332	2	1024
1341	1	8192
1342	2	8182

Table of Contents

General Information		2
Installing the 1300 Module	Chapter 1	3
	Installing the Hardware	3
	VersaPro Configuration	3
	Logic Master 90 Configuration	4
Module Specifications	Chapter 2	5
	Module Specifications	5
	Front Panel & LED Functions	6
	Transducer Wiring	6
	Wiring Notes	7
Programmable Parameters	Chapter 3	8
	Apply Preset Command	8
	Scale Factor	8
	Preset Value	8
	Count Direction	8
	Tachometer Response	9
Backplane Programming	Chapter 4	9
	Programming Cycle	9
	EEPROM Parameter Memory	9
	Output Registers	10
	Control Word	10
	Sample Data	11
	Input Registers	12
	Status Word	12
Sample Program	Chapter 5	14
Specification Revision History	Chapter 6	14

General Information

Important User Information

The products and application data described in this manual are useful in a wide variety of different applications. Therefore, the user and others responsible for applying these products described herein are responsible for determining the acceptability for each application. While efforts have been made to provide accurate information within this manual, AMCI assumes no responsibility for the application or the completeness of the information contained herein. Throughout this manual the following two notices are used to highlight important points.

WARNINGS tell you when people may be hurt or equipment may be damaged if the procedure is not followed properly.

CAUTIONS tell you when equipment may be damaged if the procedure is not followed properly. No patent liability is assumed by AMCI, with respect to use of information, circuits, equipment, or software described in this manual. The information contained within this manual is subject to change without notice. UNDER NO CIRCUMSTANCES WILL ADVANCED MICRO CONTROLS, INC. BE RESPONSIBLE OR LIABLE FOR ANY DAMAGES OR LOSSES, INCLUDING INDIRECT OR CONSEQUENTIAL DAMAGES OR LOSSES, ARISING FROM THE USE OF ANY INFORMATION CONTAINED WITHIN THIS MANUAL, OR THE USE OF ANY PRODUCTS OR SERVICES REFERENCED HEREIN.

Standard Warranty

ADVANCED MICRO CONTROLS, INC. warrants that all equipment manufactured by it will be free from defects, under normal use, in materials and workmanship for a period of [18] months. Within this warranty period, AMCI shall, at its option, repair or replace, free of charge, any equipment covered by this warranty which is returned, shipping charges prepaid, within 18 months from date of invoice, and which upon examination proves to be defective in material or workmanship and not caused by accident, misuse, neglect, alteration, improper installation or improper testing. The provisions of the “STANDARD WARRANTY” are the sole obligations of AMCI and excludes all other warranties expressed or implied. In no event shall AMCI be liable for incidental or consequential damages or for delay in performance of this warranty.

Returns Policy

All equipment being returned to AMCI for repair or replacement, regardless of warranty status, must have a Return Merchandise Authorization number issued by AMCI. Call (860) 585-1254 with the model and serial numbers along with a description of the problem. A “RMA” number will be issued. Equipment must be shipped to AMCI with transportation charges prepaid. Title and risk of loss or damage remains with the customer until shipment is received by AMCI.

24 Hour Technical Support Number

Technical Support, in the form of documents, FAQs, and sample programs, is available from our website, www.amci.com. 24 Hour technical support is also available on this product. For technical support, call (860) 583-7271. Your call will be answered by the factory during regular business hours, Monday through Friday, 8AM - 5PM EST. During non-business hours, an automated system will ask you to leave a detailed message and the telephone number that you can be reached at. The system will page an engineer on call. Please have your product model number and a description of the problem ready before you call.

Chapter 1: Installing the 1300 module

Inserting the 1300 into the Baseplate

Note: As part of our licensing agreement with GE-Fanuc, AMCI purchases the module case directly from GE-Fanuc to insure 100% compatibility with their baseplate. (We also purchase their backplane interface IC under license to insure 100% electrical compatibility with the system.) Because of this, the 1300 installs in the baseplate like every other 90-30 I/O module.

Warning: REMOVE POWER FROM THE BASEPLATE BEFORE INSTALLING OR REMOVING ANY 90-30 I/O MODULE. Installing or removing any module while power is applied may damage the module or baseplate and/or cause unexpected operation with possible injury to personnel.

To Insert the 1300

1. Grasp the module firmly with the front of the module facing you.
2. Tilt the module upwards and insert the case's top hook into the top notch of the slot.
3. Rotate the 1300 into the baseplate until the locking lever snaps into the bottom notch of the slot. It doesn't require a great deal of force to engage the backplane connectors, so do not force the module into the baseplate. Doing so may damage the backplane connectors.
4. Visually inspect the module to be sure it is properly seated.

To Remove the 1300

1. Remove the Transducer Input Connector.
2. Locate the locking lever on the bottom of the 1300 and firmly press in up. This pivots the locking hook out of the slot's bottom notch.
3. Rotate the bottom of the module out from the baseplate and disengage the hook at the top of the 1300 from the slot's top notch

Software Configuration

A 1300 module communicates with the 90-30 processor through the input and output registers assigned to the slot. The input registers are used to transmit status, position, and tachometer data (in rpm) to the PLC. The output registers are used to setup the module and Apply the Preset to the position data.

Before you can communicate with the 1300 module, you must configure the slot that it resides in.

VersaPro Configuration

If you are using the VersaPro software, this is accomplished in *Hardware Configuration*.

1. Open Hardware Configuration by clicking on the VIEW menu and selecting Hardware Configuration, or by pressing ALT+4.
2. Right click on the slot where the 1300 module is to be installed and select "Add Module..." from the menu that appears.
3. Click on the 3rd Party tab in the Module Catalog that appears.
4. Select "3rd Party" and then click on OK. A window similar to the following figure will appear.

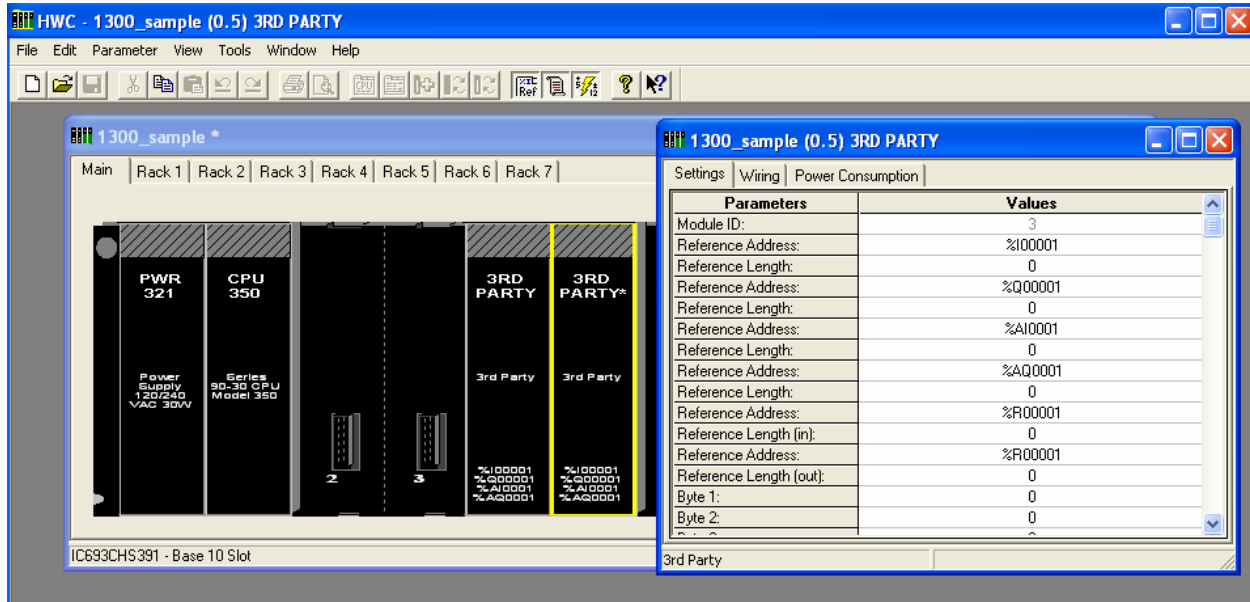

- To configure the slot, enter the reference addresses and lengths. The addresses you use depend on your application. When you choose them, make sure there's no overlap with addresses used elsewhere in your program. The length parameters for the four different 1300 modules are shown in the following table.

Module	Number of %I bits	Number of %AI words	Number of %Q bits	Number of %AQ words
1331	16	2	16	2
1332	16	4	16	5
1341	16	2	16	2
1342	16	4	16	5

Notes: The %R registers are not used and must be left at their default values.
 Bytes 1 - 16 are not used and must be left at their defaults of zero.

Logicmaster 90 Configuration

- Enter the Logicmaster 90 Configuration Package.
- Press F1 to open I/O Configuration.
- Move the cursor to the slot that the 1300 module will reside.
- Press F8 to display other module types and then press F3 to select 'frgn' (foreign).
- To configure the slot, enter the data given in the table on the previous page. The addresses you use depend on your application. When you choose them, make sure there's no overlap with addresses used elsewhere in your program. Also note that the %R registers and Bytes 1 - 16 are not used and must be left at their default values.

Chapter 2: Module Specifications

Module Location

Any 90-30 baseplate I/O slot. The following table shows the number of bits and words used by the 1300 modules.

Module	Number of %I bits	Number of %AI words	Number of %Q bits	Number of %AQ words
1331	16	2	16	2
1332	16	4	16	5
1341	16	2	16	2
1342	16	4	16	5

Baseplate Power Requirements

260mA max at 5Vdc (serial numbers 97974 and above)

66mA max at 5Vdc & 75mA at 24Vdc (serial numbers below 97974)

Compatible Transducers

These units are compatible with any AMCI single resolver based transducer, including the HT-20 series, the H25-XX series, and the HT-20-X series. The use of other transducers may also be supported with the use of AMCI RM reference modules. Please visit our website, www.amci.com for more information on these resolver transducers. Click on www.amci.com/resolvers.asp for a direct link to page containing the resolver information.

Transducer Input Isolation

Transformer Isolated (1500 Vac)

Programmable Parameters

Apply Preset

Scale Factor

Preset Value

Count Direction

Velocity Update Time

Data Transfer

Data updated automatically during program scan. Programming the module is accomplished with a *Programming Cycle*, which uses two handshaking bits (Transmit and Acknowledge).

Data Available to Processor

Status Bits, Position Data, and Tachometer Data (in RPM)

Program Storage

EEPROM. Endurance of 100,000 write cycles.

Environmental Conditions

Operating Temperature: 0 to 60° C

Relative Humidity: 5 to 95% (non-condensing)

Storage Temperature: -40 to 85° C

LED Function

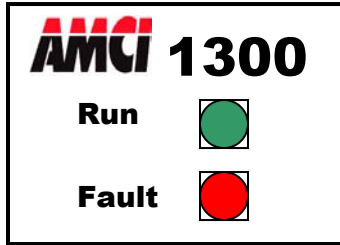

Run LED

Solid Green: This LED is on when the module is operational.

Fault Status

Off: No fault conditions exist. The Fault LED will turn off when a working transducer is attached.

Solid Red: Module fault, such as no reference voltage present

Flashing Red: Transducer Fault. Causes include a Broken Transducer cable, Non-compatible transducer, Improperly wired cable, or a Faulty Transducer. The Fault LED will also flash if only one transducer is attached to a 1332 or a 1342 module.

Transducer Input Connectors

The Transducer Input Connector has eight contacts. The mating connector is supplied with the 1300 module. The pre-assembled cable, AMCI part number CTL-X where X is the length in feet, is available from AMCI and will have tinned pig-tailed wires that you can wire into the MS-8 connector. The AMCI part number for the mating connector is MS-8, while the Phoenix Contact part number is MSTB2.5/8-ST-5.08, order number 1757077. The following figure shows the connector pinout to industry standard wire designations.

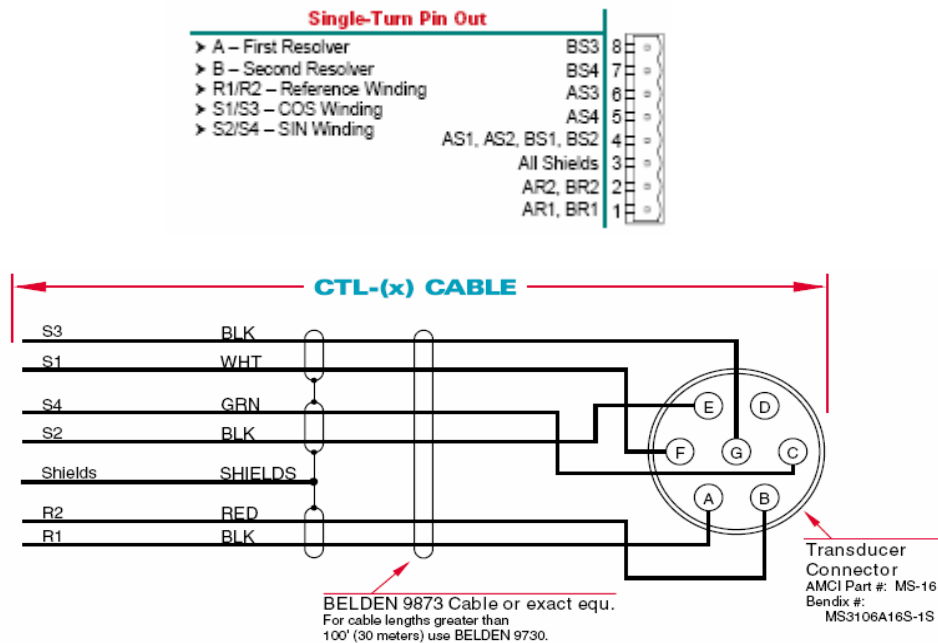

One Resolver Cable Wiring

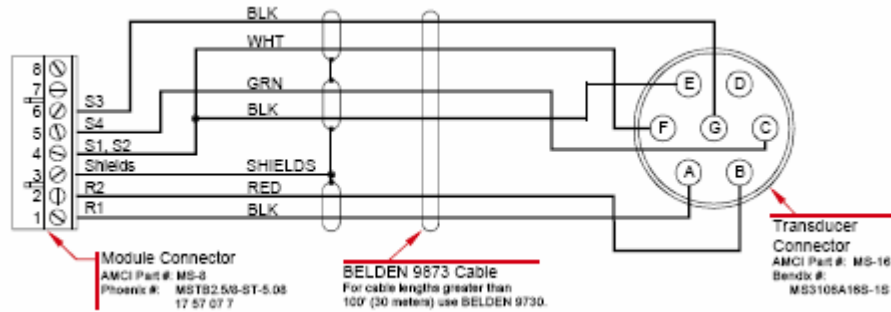

Two Resolver Cable Wiring

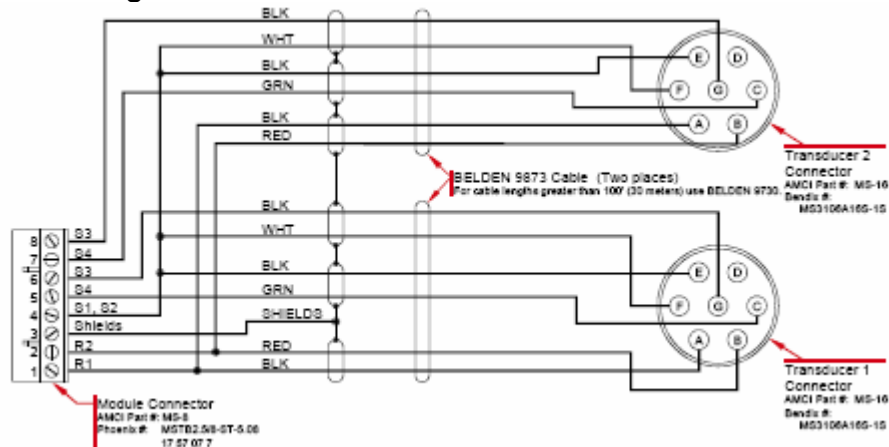

Wiring Notes:

- When installed in the 1300 module, pin 1 of the MS-8 connector, the R1 signal, is located at the bottom of the module.
- Resolver signals are low voltage, low power signals. It can be installed in conduit along with other low power cabling such as communication cables and low power ac/dc I/O lines. It cannot be installed in conduit with ac power lines or high power ac/dc I/O lines.
- AMCI recommends the use of either the Beldin 9873 or 9730 or equivalent cables to connect the resolver to the 1300 module. While the Beldin 9730 can be used for any length of cable run, the 9783 can only be used for runs less than 100 feet.
- To reduce or eliminate the influence of electrical noise on the system, the resolver cable shields must be connected to shield pin 3. Also, the shields must be connected to only one end of the cable run and treated as conductors at any junctions. Do not ground the shields at the junction box.
- If electrical noise is causing your resolver counts to jump, try running a heavy wire from the shield pin, pin 3, to your earth ground bus. This will provide a better low impedance path to ground.
- If the resolver cable must cross power feed lines, it should do so at right angles.
- Route the cable at least five feet from high voltage enclosures, or sources of “rf” radiation.

Chapter 3: Programmable Parameters

Apply Preset Command:

Offsetting the Data Value to the Preset Value is a two step operation. First, the Preset Value must be saved in the module's memory. Second, setting the Apply Preset Command bit will change the Data Value to the Preset Value. It is possible both program the Preset Value and Apply the Preset in one programming cycle.

Setting the Apply Preset bit causes the module to generate an internal offset value that is applied to the Position Data before it is reported to the PLC. This internal offset is saved in the 1300 module's EEPROM memory, so it is not necessary to home the module at every power up.

WARNING The 1300 module's EEPROM memory is guaranteed for 100,000 write cycles before writing to it will cause it to fault. Therefore continuously Applying the Preset should be avoided. If your application requires you to continuously Apply the Preset, consider calculating and Applying the Preset in your PLC program. A FAQ showing how to calculate and apply a preset value is located in the FAQ section of our website.

Scale Factor

The Scale Factor specifies the number of counts generated by the 1300 module. For single-turn transducers, such as the HT-20's and H25's, this is the number of counts generated per turn. In the case of our multi-turn transducers, such as the HT-20-(x) family, this is the number of counts generated over the transducer's number of turns. (For example, an HT-20-20 with a Scale Factor of 1,000 would generate 1,000 counts over 20 turns. This equals $1,000/20 = 50$ counts per turn.)

- The default Scale Factor is 360. Setting the Scale Factor to 360 gives 1 degree resolution.
- Range for 1331 and 1332 modules is 2 to 1024.
- Range for 1341 and 1342 modules is 2 to 8,192.

Preset Value

The Preset Value parameter allows you to set the value of the position data to any count value within its range. The range of the count values is 0 to (Scale Factor - 1). Programming the Preset Value does not change the position data; it only sets in the module's memory the value that the position value will change to when an *Apply Preset* command is initiated.

- The default Preset Value is 0.
- The range of the Preset Value is 0 to (Scale Factor - 1).

Count Direction

This parameter sets the direction of transducer shaft rotation that increases the position count. *If the transducer is wired as specified in this manual* and the count direction is set to *positive*, the count will increase with clockwise rotation, (looking at the shaft). If the count direction is set to *negative*, the position count will increase with counter-clockwise rotation.

- The default Count Direction Value is *positive*.

It is also possible to reverse the count direction by reversing the S2 S4 wire pairs in the transducer cable. Once the machine is setup, you can easily change this parameter if the position is increasing in the wrong direction.

Note: The Count Direction Function is only available on units with serial number 97974 and above.

Tachometer Response

This parameter sets the time between tachometer updates. It *only* affects the update time of the tachometer. It *does not* affect the update time of the position value, which is always 200 microseconds.

- The default Tachometer Response is 120 milliseconds.
- The Tachometer Response can be set to 120 or 32 milliseconds.
- Programming the tachometer response affects both channels of a 1332 or 1342 module.

Chapter 4: Backplane Programming

The 1300 module is programmed over the backplane through the input and output words assigned to it. Because these words are constantly updated, the unit implements a simple hand-shaking protocol to control when it accepts new programming data. This hand-shaking protocol is called a Programming Cycle

Programming Cycle

A Programming cycle consists of six steps and is controlled by the *Transmit Bit* in the output data words and the *Acknowledge Bit* in the input data words.

- a. Write the new programming data into the output data words with the Transmit Bit reset. This step insures that the correct data is in the output data words before the Programming Cycle begins.
- b. Set the Transmit bit. A Programming Cycle is initiated when this bit makes a 0 to 1 transition.
- c. Once the unit is done with the programming data, it will set any necessary error bits and the Acknowledge Bit in its input data words.
- d. Once you see the Acknowledge Bit set, check for any errors. The error bits are only valid while the Acknowledge Bit is set.
- e. Respond to any errors and reset the Transmit Bit.
- f. The 1300 module responds by resetting the Acknowledge Bit. The Programming Cycle is complete.

EEPROM Parameter Memory

Parameter values are stored in a non-volatile EEPROM memory. This memory type can store parameter values in the absence of power for over twenty years, but you can only write to it a limited number of times before it will be damaged. The EEPROM Memory that AMCI uses is guaranteed for a minimum of 100,000 write cycles.

Every time you have the Apply Preset bit set during a programming cycle, the 1300 module calculates an offset and stores this value in the EEPROM. If your application requires you to continuously Apply the Preset Value, consider doing this in the PLC instead of the 1300 module.

A FAQ showing how to calculate and apply a preset value is located on the following page of our website.

<http://www.amci.com/faqs.asp>

Output Registers: (Data sent from the PLC to the 1300 module)

The 1300 module is configured through 16 %Q bits and either two (for 1331 and 1341) or five (for 1332 and 1342) %AQ registers. The function of these bits and words is shown below.

Data Type	Function	Range
%Q Bits	Control Word (see below)	See description below
%AQ register 1	Scale Factor Channel 1	2 to 1024 for 1331 and 1332 modules 2 to 8192 for 1341 and 1342 modules
%AQ register 2	Preset Value Channel 1	0 to (Scale Factor – 1)
%AQ register 3	Reserved	Must be zero
%AQ register 4	Scale Factor Channel 2 (1332 & 1342 units only)	2 to 1024 for 1331 and 1332 modules 2 to 8192 for 1341 and 1342 modules
%AQ register 5	Preset Value Channel 2 (1332 & 1342 units only)	0 to (Scale Factor – 1)

Control Word

Bit 16	Bit 15	Bit 14	Bit 13	Bit 12	Bit 11	Bit 10	Bit 09	Bit 08	Bit 07	Bit 06	Bit 05	Bit 04	Bit 03	Bit 02	Bit 01
Transmit Bit	Clear EEPROM Error	0	0	Direction Ch 2 0 = Positive 1 = Negative	Direction Ch 1 0 = Positive 1 = Negative	Tach Response, 0 = 120ms, 1 = 32ms	Program Setup	0	Preset Value Channel 2	Scale Factor Channel 2	0	Preset Value Channel 1	Scale Factor Channel 1	Apply Preset Channel 2	Apply Preset Channel 1

Bit 1: Apply Preset Channel 1. Set to force the position data of channel 1 to the channel 1 preset value.

Bit 2: Apply Preset Channel 2. Set to force the position data of channel 2 to the channel 2 preset value.

Bit 3: Scale Factor Channel 1. Set to program the Channel 1 Scale Factor to the value contained in %AQ Register 1. The Scale Factor has a range of 2 to 1024 for 133X modules, and 2 to 8192 for 134X modules. If this bit is not set, the module will ignore the data in the %AQ Register 1.

Programming the Scale Factor clears the internal offset generated by an Apply Preset Command

Bit 4: Preset Value Channel 1. Set to program the Channel 1 Preset Value to the number contained in %AQ Register 2. The Preset Value has a range of 0 to (Scale Factor –1). If this bit is not set, the module will ignore the data in the %AQ Register 2.

Bit 5: Reserved, must be set to zero.

Bit 6: Scale Factor Channel 2. Set to program the Channel 2 Scale Factor to the value contained in %AQ Register 4. The Scale Factor has a range of 2 to 1024 for 133X modules, and 2 to 8192 for 134X modules. If this bit is not set, the module will ignore the data in the %AQ Register 4. This bit must remain reset to zero on 1331 and 1341 module or a Command Error will be generated.

Programming the Scale Factor clears the internal offset generated by an Apply Preset Command.

Bit 7: Preset Value Channel 2. Set to program the Channel 2 Preset Value to the number contained in %AQ Register 2. The Preset Value has a range of 0 to (Scale Factor –1). If this bit is not set, the module will ignore the data in the %AQ Register 5. This bit must remain reset to zero on 1331 and 1341 module or a Command Error will be generated.

Bit 8: Reserved, must be set to zero.

Bit 9: Setup. Set to program the setup data in bits %Q10, %Q11, and %Q12.

Bit 10: Tachometer Response. This bit is only valid when bit 9 is set. Set this bit to “0” to set the Tachometer Response time to 120ms. Set this bit to “1” to set the Tachometer Response Time to 32ms. The Tachometer Response time programmed here affects both channels of a two channel unit.

Bit 11: Direction Channel 1. This bit is only valid when bit 9 is set. Set this bit to “0” to set the channel 1 direction of increasing counts to Positive. Set this bit to “1” to set the channel 1 direction of increasing counts to Negative.

Bit 12: Direction Channel 2. This bit is only valid when bit 9 is set. Set this bit to “0” to set the channel 2 direction of increasing counts to Positive. Set this bit to “1” to set the channel 2 direction of increasing counts to Negative. Setting this bit on a 1331 or 1341 unit will cause a Command Error to be generated.

Note: The Count direction parameters are only available on 1300 modules with serial number 97974 or above.

Bit 15: Clear E² Error. Set this bit to one to clear an EEPROM Memory Fault.

Bit 16: Transmit Bit. The zero to one transition of this bit initiates a program transfer.

WARNING: The Internal Offset generated by an Apply Preset operation will be reset to zero when the channel’s Scale Factor is programmed.

1332 Sample Programming Data

Output Word	Value	Function
%Q	1350 (0546h)	Bit 11 = Channel 1 direction set to Negative Bit 9 = Setup Command bit set Bit 7 = Program Preset Value Channel 2 Bit 3 = Program Scale Factor Channel 1 Bit 2 = Apply Preset Channel 2
%AQ1	360	Scale Factor Channel 1
%AQ2	0	Preset Value Channel 1 (not being programmed)
%AQ3	0	Resereved, Must be zero
%AQ4	360	Scale Factor Channel 2 (not being programmed)
%AQ5	123	Preset Value Channel 2

Input Registers (Data sent from the 1300 module to the PLC)

The 1300 module reports its position, velocity, and status information through 16 %I bits and either two (for 1331 and 1341) or four (for 1332 and 1342) %AI registers. The function of these bits and words is shown below.

Data Type	Function	Units
%I Bits	Status Word (see below)	See description below
%AI register 1	Position Transducer 1	Counts
%AI register 2	Tachometer Transducer 1	Revolutions / Minute (RPM)
%AI register 3	Position Transducer 2 (1332 & 1342 units only)	Counts
%AI register 4	Tachometer Transducer 2 (1332 & 1342 units only)	Revolutions / Minute (RPM)

Status Word

Bit 16	Bit 15	Bit 14	Bit 13	Bit 12	Bit 11	Bit 10	Bit 09	Bit 08	Bit 07	Bit 06	Bit 05	Bit 04	Bit 03	Bit 02	Bit 01
Acknowledge Bit	Transducer Fault Channel 1	Transducer Fault Channel 2	EEPROM Error	0	0	0	0	Message Ignored	Command Error	Setup Error	Preset Value Channel 2 Error	Scale Factor Channel 2 Error	0	Preset Value Channel 1 Error	Scale Factor Channel 1 Error

Bit 1: Scale Factor 1 Error. Set when the Channel 1 Scale Factor is outside of the range of 2 to 1024 for 133X units or 2 to 8192 for the 134X units.

Bit 2: Preset Value 1 Error. Set when the Channel 1 Preset Value is outside the range of 0 to (SF – 1).

Bit 3: Reserved, will always be zero

Bit 4: Scale Factor 2 Error. Set when the Channel 2 Scale Factor is outside of the range of 2 to 1024 for 133X units or 2 to 8192 for the 134X units.

Bit 5: Preset Value 2 Error. Set when the Channel 2 Preset Value is outside the range of 0 to (SF – 1).

Bit 6: Setup Error. Set when bits 10,11, or 12 are set without bit 9 set, and there is at least one other valid command bit set in the command word.

Bit 7: Command Error. Set under the following seven conditions. A Command Error is reset after valid data has been sent to the module.

- 1) An attempt to program the module while there is an E² Error.
- 2) No Command Bits are set when a program transfer is initiated.
- 3) %Q bits specified as zero are set to 1.
- 4) If %Q bits 10, 11, and 12 are set when there are no other valid command bits set in the command word.
- 5) Attempting to program any of the channel 2 parameters on a one channel module.
- 6) If bit %Q12, the channel 2 direction bit, is set and a one channel module is being used.
- 7) If direction bits %Q11 and %Q12 are set on a unit with a serial number less than 97974.

Bit 8: Message Ignored: If an error bit is set, the error must be cleared by programming the affected parameter. This bit is set, along with the original error bit, if you attempt to program a different parameter before clearing the error. This bit will also be set if an attempt is made to apply the preset value to a channel that is in transducer fault.

Bit 9 to 12: Reserved, will always be zero

Bit 13: EEPROM Error. Set when there is an EEPROM Memory Fault. If cycling power does not clear this error, the unit must be returned for repair.

Bit 14: Transducer 2 Error. Set when there is a transducer fault on the second channel. This error will clear itself when the channel is correctly connected to a compatible resolver.

Bit 15: Transducer 1 Error. Set when there is a transducer fault on the first channel. This error will clear itself when the channel is correctly connected to a compatible resolver.

Bit 16: Acknowledge Bit. Set by the module to acknowledge the receipt of programming data from the processor. This bit will remain set as long as the Transmit Bit remains set. The module resets the Acknowledge Bit after the processor resets the Transmit Bit.

Chapter 5: Sample Program

The three rung ladder logic below shows how to program a 1300 module. This example assumes that a 1332 module is being programmed and that it has been assigned the lowest possible register and bit addresses. The program also uses %R1 to %R6 to store the data that is sent to the 1332 module.

%R1 = 1350 (0546 hex) = Bits to copy to %Q1 to %Q16. Sets the Channel 1 Direction to negative, programs the Channel 2 Preset Value, programs the Channel 1 Scale Factor, and Applies the Preset to Channel 2.

%R2 = 360 = Channel 1 Scale Factor

%R3 = 0 = Channel 1 Preset Value (not being programmed)

%R4 = 0 = Reserved Word

%R5 = 360 = Channel 2 Scale Factor (not being programmed)

%R6 = 123 = Channel 2 Preset Value

Bit %M00017 is used to initiate a Programming Cycle. When this bit is set, either manually or by the ladder logic program, and the Acknowledge Bit (%I00016) from the 1300 module is not set, copy the data stored in %R1 to Control Word Bits %Q00001 and the five words of programming data, starting at %R2, into the data words %AQ1 to %AQ5. Please note that bit 16 of %R1, which is copied to the Transmit bit of the 1300 module, is not set.

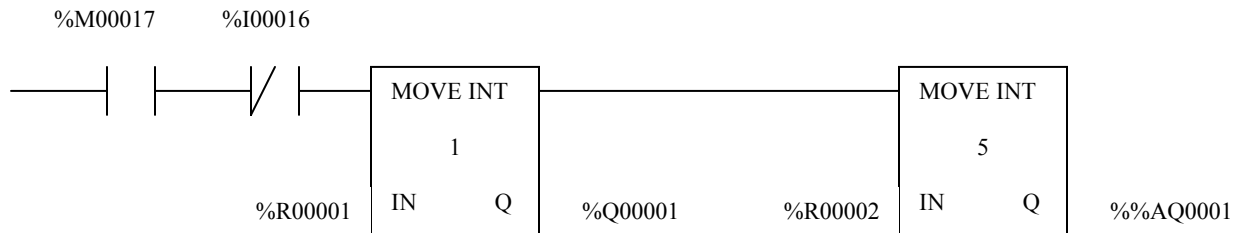

As long as a Programming Cycle is initiated, and the 1300 module has not responded by setting its Acknowledge Bit, set the Transmit Bit %Q00016.

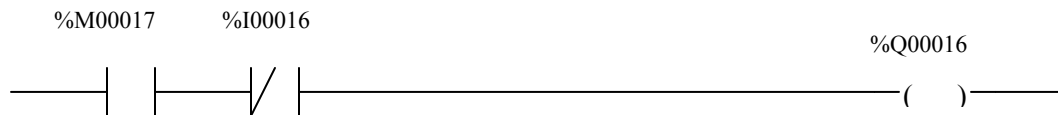

Once the 1300 module responds by setting its Acknowledge bit (%I00016) terminate the Programming Cycle by resetting (%M00017), the bit that initiated the Programming Cycle.



Chapter 6: Specification Revision History

Revision 2.0 was created on 10/07/05 and replaces manual 1300-295M.