

Module Overview

Utilizing licensed GE Fanuc Series 90-30 I/O interface technology, the 1361 module plugs directly into GE Fanuc 90-30 or PACsystem RX3I racks and accepts signals from one dual resolver transducer.

Communicating through I/O registers assigned to the slot, these modules supply absolute position and tachometer data from an AMCI resolver based transducer to any 90-30 CPU.

This manual explains the installation and operation of the following module.

Module	Number of Channels	Maximum Resolution (counts/turn)
1361	1	4096

Table of Contents

General Information		2
Installing the 1361 Module	Chapter 1	3
	Installing the Hardware	3
	Proficy Configuration	3
	VersaPro Configuration	5
	Logic Master 90 Configuration	5
Module Specifications	Chapter 2	6
	Module Specifications	6
	Front Panel & LED Functions	7
	Transducer Wiring	7
	Wiring Notes	8
Programmable Parameters	Chapter 3	9
	Reset Position Data Command	9
	Transducer Type	9
	Number of Turns	10
	Full Scale Count	10
	Count Direction	11
Backplane Programming	Chapter 4	11
	Programming Cycle	11
	EEPROM Parameter Memory	11
	Output Registers	12
	Control Word	12
	Input Registers	13
	Status Word	13
Sample Program	Chapter 5	14
Specification Revision History	Chapter 6	14

General Information

Important User Information

The products and application data described in this manual are useful in a wide variety of different applications. Therefore, the user and others responsible for applying these products described herein are responsible for determining the acceptability for each application. While efforts have been made to provide accurate information within this manual, AMCI assumes no responsibility for the application or the completeness of the information contained herein. Throughout this manual the following two notices are used to highlight important points.

WARNINGS tell you when people may be hurt or equipment may be damaged if the procedure is not followed properly.

CAUTIONS tell you when equipment may be damaged if the procedure is not followed properly. No patent liability is assumed by AMCI, with respect to use of information, circuits, equipment, or software described in this manual. The information contained within this manual is subject to change without notice. UNDER NO CIRCUMSTANCES WILL ADVANCED MICRO CONTROLS, INC. BE RESPONSIBLE OR LIABLE FOR ANY DAMAGES OR LOSSES, INCLUDING INDIRECT OR CONSEQUENTIAL DAMAGES OR LOSSES, ARISING FROM THE USE OF ANY INFORMATION CONTAINED WITHIN THIS MANUAL, OR THE USE OF ANY PRODUCTS OR SERVICES REFERENCED HEREIN.

Standard Warranty

ADVANCED MICRO CONTROLS, INC. warrants that all equipment manufactured by it will be free from defects, under normal use, in materials and workmanship for a period of [18] months. Within this warranty period, AMCI shall, at its option, repair or replace, free of charge, any equipment covered by this warranty which is returned, shipping charges prepaid, within 18 months from date of invoice, and which upon examination proves to be defective in material or workmanship and not caused by accident, misuse, neglect, alteration, improper installation or improper testing. The provisions of the "STANDARD WARRANTY" are the sole obligations of AMCI and excludes all other warranties expressed or implied. In no event shall AMCI be liable for incidental or consequential damages or for delay in performance of this warranty.

Returns Policy

All equipment being returned to AMCI for repair or replacement, regardless of warranty status, must have a Return Merchandise Authorization number issued by AMCI. Call (860) 585-1254 with the model and serial numbers along with a description of the problem. A "RMA" number will be issued. Equipment must be shipped to AMCI with transportation charges prepaid. Title and risk of loss or damage remains with the customer until shipment is received by AMCI.

24 Hour Technical Support Number

Technical Support, in the form of documents, FAQs, and sample programs, is available from our website, www.amci.com. 24 Hour technical support is also available on this product. For technical support, call (860) 583-7271. Your call will be answered by the factory during regular business hours, Monday through Friday, 8AM - 5PM EST. During non-business hours, an automated system will ask you to leave a detailed message and the telephone number that you can be reached at. The system will page an engineer on call. Please have your product model number and a description of the problem ready before you call.

Chapter 1: Installing the 1361 module

Inserting the 1361 into the Baseplate

Note: As part of our licensing agreement with, AMCI purchases the module case directly from GE-Fanuc to insure 100% compatibility with their baseplate. (We also purchase their backplane interface IC under license to insure 100% electrical compatibility with the system.) Because of this, the 1361 installs in the baseplate like every other 90-30 I/O module.

**WARNING**

REMOVE POWER FROM THE BASEPLATE BEFORE INSTALLING OR REMOVING ANY 90-30 I/O MODULE. Installing or removing any module while power is applied may damage the module or baseplate and/or cause unexpected operation with possible injury to personnel.

To Insert the 1361

1. Grasp the module firmly with the front of the module facing you.
2. Tilt the module upwards and insert the case's top hook into the top notch of the slot.
3. Rotate the 1361 into the baseplate until the locking lever snaps into the bottom notch of the slot. It doesn't require a great deal of force to engage the backplane connectors, so do not force the module into the baseplate. Doing so may damage the backplane connectors.
4. Visually inspect the module to be sure it is properly seated.

To Remove the 1361

1. Remove the Transducer Input Connector.
2. Locate the locking lever on the bottom of the 1361 and firmly press in up. This pivots the locking hook out of the slot's bottom notch.
3. Rotate the bottom of the module out from the baseplate and disengage the hook at the top of the 1361 from the slot's top notch

Software Configuration

A 1361 module communicates with the PLC through the input and output registers assigned to the slot. The input registers are used to transmit status, position, and tachometer data (in rpm) to the PLC. The output registers are used to setup the module and Reset the Position data to zero.

Before you can communicate with the 1361 module, you must configure the slot that it resides in. The 1361 module has been tested with the Proficy, VersaPro, and Logimaster software packages.

Proficy Configuration

1. In the Project tab of the Navigator, expand the Hardware Configuration node by clicking the + to the left of it. The tree expands to show the default set of racks. Each rack has its model number shown to the right of it.
2. Click on the + to the left of the rack where you want to install the 1361 module.
3. Right click on the slot where the AMCI module is to be installed and select "Add Module..." from the menu that appears.
4. Click on the *3rd Party* tab in the Module Catalog window.
5. If it is not already highlighted, select the 3RD PARTY Catalog Number and click on the OK button. The following window will appear.

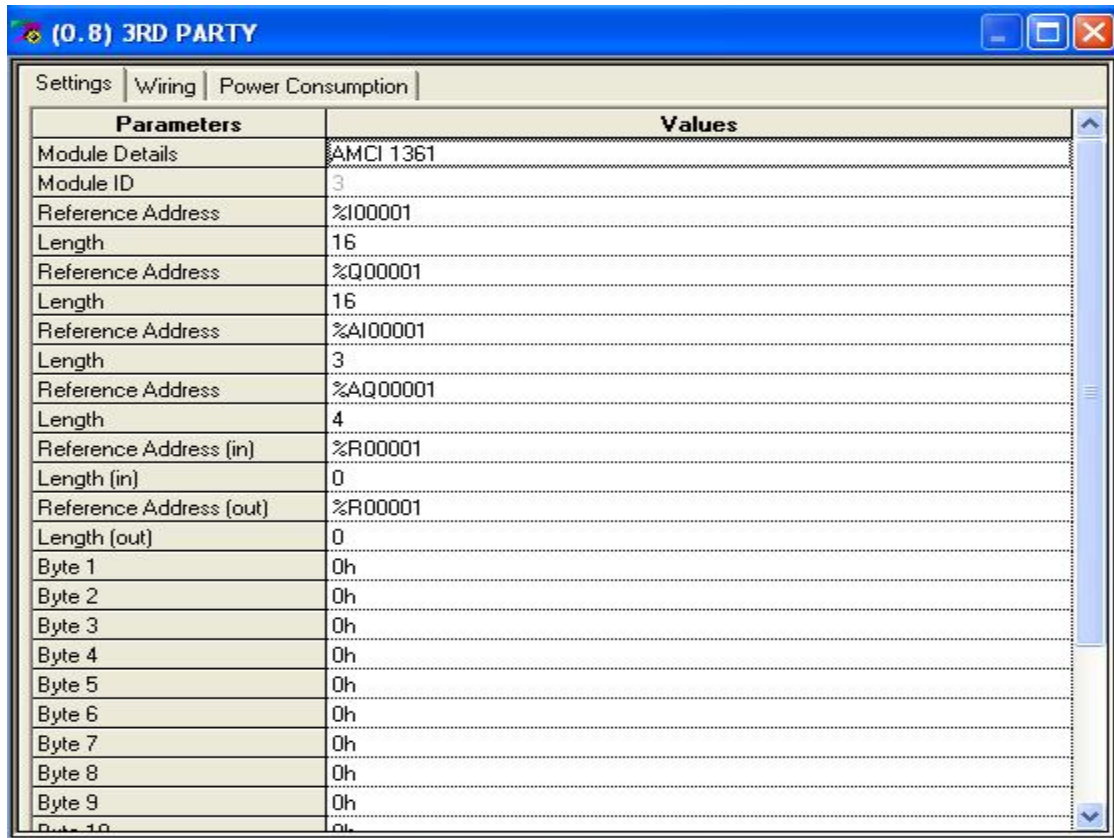

6. Enter the following information into this window.

Module Details: Optional field, 32 characters max, typically the vendor name and model number are entered here.

Module ID: Fixed at 3.

Reference Addresses: The addresses you use depend on your application. When you choose them, make sure there is no overlap with addresses used elsewhere in your program. The length parameters for the 1361 module are shown in the following table.

Module	Number of %I bits	Number of %Q bits	Number of %AI words	Number of %AQ words
1361	16	16	3	4



The Byte 1 through Byte 16 parameters and the %R Reference Addresses in and out must be left at their default values of zero.

7. There are two other tabs available on the Module Configuration screen, *Wiring* and *Power Consumption*. Entering data in these fields is optional, but recommended.

VersaPro Configuration

If you are using the VersaPro software, this is accomplished in *Hardware Configuration*.

1. Open Hardware Configuration by clicking on the VIEW menu and selecting Hardware Configuration, or by pressing ALT+4.
2. Right click on the slot where the 1361 module is to be installed and select “Add Module...” from the menu that appears.
3. Click on the 3rd Party tab in the Module Catalog that appears.
4. Select “3rd Party” and then click on OK. A window similar to the following figure will appear.

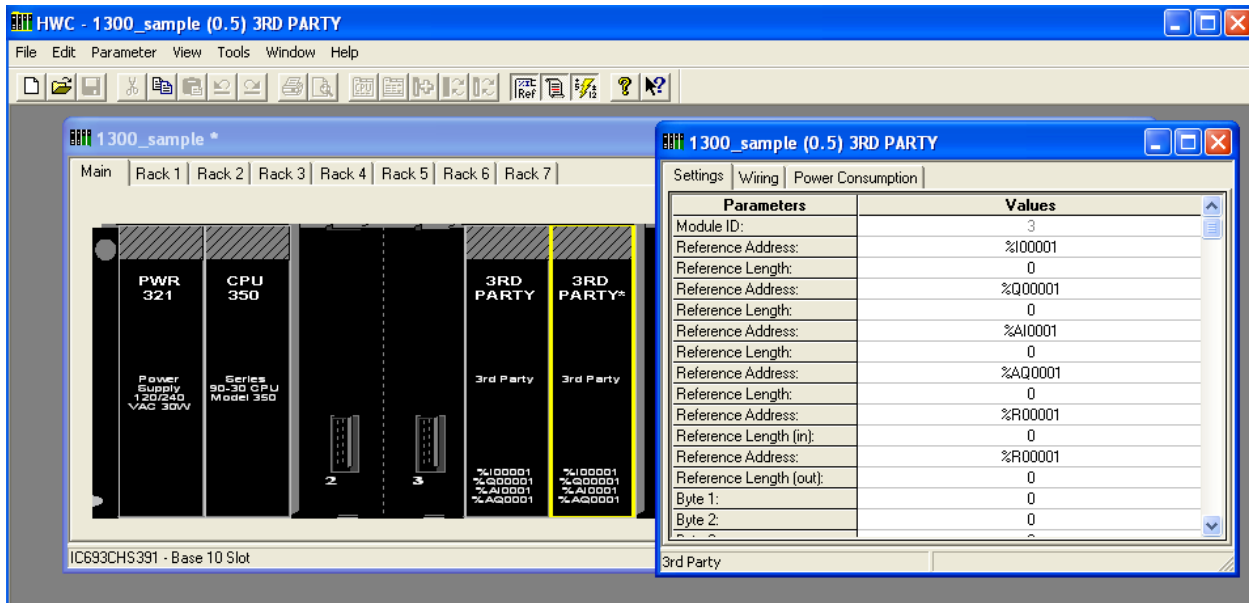

5. To configure the slot, enter the reference addresses and lengths. The addresses you use depend on your application. When you choose them, make sure there’s no overlap with addresses used elsewhere in your program. The length parameters for 1361 module is shown in the following table.

Module	Number of %I bits	Number of %Q bits	Number of %AI words	Number of %AQ words
1361	16	16	3	4

Notes: The %R registers are not used and must be left at their default values.

Bytes 1 - 16 are not used and must be left at their defaults of zero.

Logicmaster 90 Configuration

1. Enter the Logicmaster 90 Configuration Package.
2. Press F1 to open I/O Configuration.
3. Move the cursor to the slot that the 1361 module will reside.
4. Press F8 to display other module types and then press F3 to select ‘frgn’ (foreign).
5. To configure the slot, enter the data shown in the table in the VersaPro configuration section above. The addresses you use depend on your application. When you choose them, make sure there’s no overlap with addresses used elsewhere in your program. Also note that the %R registers and Bytes 1 - 16 are not used and must be left at their default values.

Chapter 2: Module Specifications

Module Location

Any 90-30 or RX3i baseplate I/O slot. The following table shows the number of bits and words used by the 1361 module.

Module	Number of %I bits	Number of %Q bits	Number of %AI words	Number of %AQ words
1361	16	16	3	4

Baseplate Power Requirements

260mA max at 5Vdc (serial numbers 97974 and above)

66mA max at 5Vdc & 75mA at 24Vdc (serial numbers below 97974)

Compatible Transducers

These units are compatible with any AMCI dual resolver based transducer in the HTT-20-X series. 64 turn Autotech RL210 transducers are also supported. Please visit our website, www.amci.com for more information on these resolver transducers. Click on www.amci.com/resolvers.asp for a direct link to page containing the resolver information.

Transducer Input Isolation

Transformer Isolated (1500 Vac)

Programmable Parameters

Reset Position Data to Zero

Count Direction

Transducer Type

Number of Turns

Full Scale Count

Data Transfer

Data updated automatically during program scan. Programming the module is accomplished with a *Programming Cycle*, which uses two handshaking bits (Transmit and Acknowledge).

Data Available to Processor

Status Bits, Position Data, and Tachometer Data (in RPM)

Program Storage

EEPROM. Endurance of 100,000 write cycles.

Environmental Conditions

Operating Temperature: 0 to 60° C

Relative Humidity: 5 to 95% (non-condensing)

Storage Temperature: -40 to 85° C

LED Function

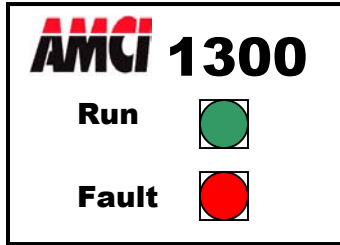

Run LED

Solid Green: This LED is on when the module is operational.

Fault Status

Off: No fault conditions exist. The Fault LED will turn off when a working transducer is attached.

Solid Red: Module fault, such as no reference voltage present

Flashing Red: Transducer Fault. Causes include a Broken Transducer cable, Non-compatible transducer, Improperly wired cable, or a Faulty Transducer.

Transducer Input Connectors

The Transducer Input Connector has eight contacts. The mating connector is supplied with the 1361 module. A pre-assembled cable, AMCI part number CML-X where X is the length in feet, is available from AMCI and will have tinned pig-tailed wires that you can wire into the MS-8 connector. The following figure shows both how to wire the CML-X cable to the MS-8 connector and the industry standard resolver designations.

Resolver Cable Wiring

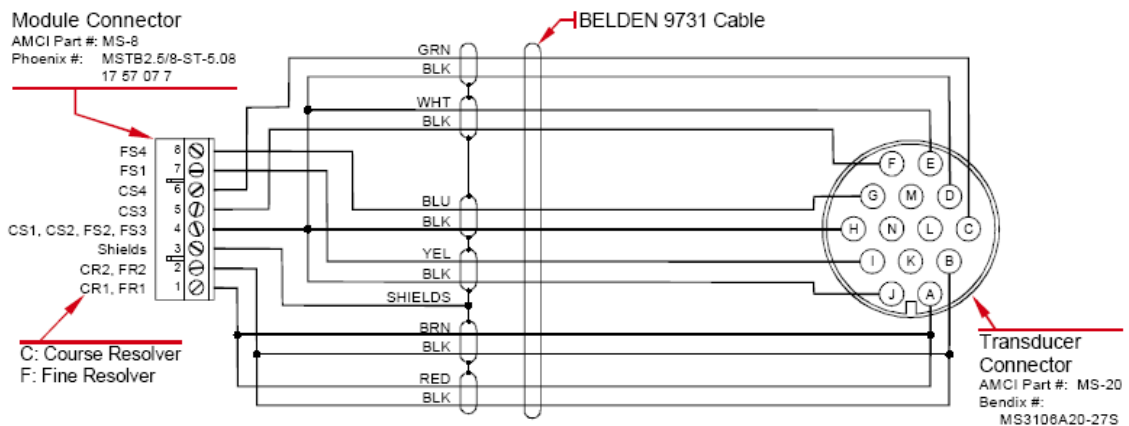

Note: Pin 1 is located at the bottom of the MS-8 connector when it is plugged into the 1361 module.

Wiring Notes:

- When installed in the 1361 module, pin 1 of the MS-8 connector, the R1 signal, is located at the bottom of the module.
- Resolver signals are low voltage, low power signals. It can be installed in conduit along with other low power cabling such as communication cables and low power ac/dc I/O lines. It cannot be installed in conduit with ac power lines or high power ac/dc I/O lines.
- AMCI recommends the use of the Beldin 9731 or equivalent cables to connect the resolver to the 1361 module.
- To reduce or eliminate the influence of electrical noise on the system, the resolver cable shields must be connected to shield pin 3. Also, the shields must be connected to only one end of the cable run and treated as conductors at any junctions. Do not ground the shields at the junction box.
- If electrical noise is causing your resolver counts to jump, try running a heavy wire from the shield pin, pin 3, to your earth ground bus. This will provide a better low impedance path to ground.
- If the resolver cable must cross power feed lines, it should do so at right angles.
- Route the cable at least five feet from high voltage enclosures, or sources of “rf” radiation.

Chapter 3: Programmable Parameters

You configure your 1361 module by setting the values of its programmable parameters. These parameters are stored in the modules nonvolatile memory. Therefore, you do not have to configure the module after every power up. The nonvolatile memory is an EEPROM that is rated for approximately 100,000 write cycles.

Reset Position Data Command:

Setting this bit during a programming cycle causes the 1361 module to force the position data to zero.

Setting the Reset Position Data bit causes the module to generate the internal offset necessary to force the position data to zero. The internal offset is saved in the 1361 module's EEPROM memory, so it is not necessary to home the module at every power up. This internal offset will also be cleared whenever the Transducer Setup parameters are programmed.



The 1361 module's EEPROM memory is guaranteed for 100,000 write cycles before writing to it will cause it to fault. Therefore continuously setting this bit should be avoided. If your application requires you to continuously Reset the Position Data, consider performing this operation in your PLC program. A FAQ showing how to Offset the Position Data in the PLC is located in the FAQ section of our website.

Transducer Type

This parameter specifies the type of transducer attached to the input channel. The 1361 module needs this information in order to combine the positions of the two resolvers inside the transducer into one multi-turn position.

- The default value is 100. This value is for all AMCI 100 turn transducers
- The Transducer Type can be programmed to 100, 180, 1,000, 1,800, and 64.
- Set the Transducer Type to 64 to support Autotech 64 turn RL210 transducers. The 1361 will automatically set the transducer's reference voltage to the proper value.
- The Transducer Type, Number of Turns, Full Scale Count, and Count Direction parameters are programmed as a group. All four values must be correct before any of them are accepted.
- Programming the Transducer Type resets the internal offset that was generated by a Reset Position Data command.

Number of Turns

The maximum number of turns a transducer can encode is fixed by the gearing inside of it. However, the 1361 module has the ability to divide this maximum number of turns into smaller multi-turn cycles. The module does this without loss of absolute position within the smaller cycle. An example of this feature is shown in the following figure. It shows how the 180 turn mechanical cycle of an HTT-20-180 can be broken down into three electronic cycles of sixty turns each. The 180 turn cycle could also be broken down into sixty cycles of three turns each.

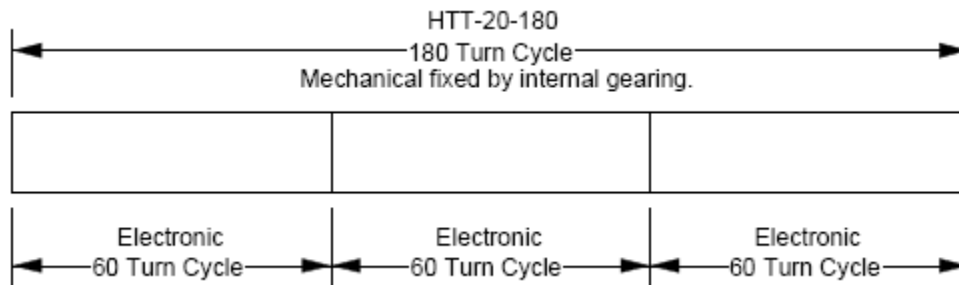

The range of values for the Number of Turns parameter is dependent on the value of the *Transducer Type* parameter.

- **When Transducer Type = 100:** Number of Turns is programmable to 1, 2, 4, 5, 10, 20, 25, 50, or 100.
- **When Transducer Type = 180:** Number of Turns is programmable to 1, 2, 3, 4, 5, 6, 9, 10, 12, 15, 18, 20, 30, 36, 45, 60, 90, or 180.
- **When Transducer Type = 1,000:** Number of Turns is programmable to 10, 20, 40, 50, 100, 200, 250, 500, or 1,000.
- **When Transducer Type = 1,800:** Number of Turns is programmable to 10, 20, 30, 40, 50, 60, 90, 100, 120, 150, 180, 200, 300, 360, 450, 600, 900, or 1,800.
- **When Transducer Type = 64:** Number of Turns is programmable to 1, 2, 4, 8, 16, 32, or 64.
- Transducer types 1000 and 1800 are not available on units with a serial number lower than 97974.
- The Transducer Type, Number of Turns, Full Scale Count, and Count Direction parameters are programmed as a group. All four values must be correct before any of them are accepted.

Full Scale Count

This Double Precision integer parameter specifies the number of counts over the programmed number of turns. The range of values for the Full Scale Count parameter is dependent on the values of the *Transducer Type* and *Number of Turns* parameters.

For AMCI Transducers

- Default value is (Number of Turns * 4,096) if Transducer Type equals 100 or 180
- Default value is (Number of Turns * 409.6) if Transducer Type equals 1,000 or 1,800
- Range is 2 to (Default Value)
- Units with a serial number below 97974 will have a maximum scale factor of 1024 counts per turn.

For Autotech Transducers (Transducer Type equals 64)

- Default value is (Number of Turns parameter) * 1,024
- Range is 2 to (Default Value)
- The Transducer Type, Number of Turns, Full Scale Count, and Count Direction parameters are programmed as a group. All four values must be correct before any of them are accepted.

Count Direction

This parameter sets the direction of transducer shaft rotation that increases the position count. *If the transducer is wired as specified in this manual* and the count direction is set to *positive*, the count will increase with clockwise rotation, (looking at the shaft). If the count direction is set to *negative*, the position count will increase with counter-clockwise rotation.

- The default Count Direction Value is *positive*.
- The Count direction parameter is only available on 1361 modules with a serial number of 97974 or above.
- The Transducer Type, Number of Turns, Full Scale Count, and Count Direction parameters are programmed as a group. All four values must be correct before any of them are accepted.

Note: It is also possible to reverse the count direction by reversing the Green/Black and Blue/Black wire pairs. This reverses the S2-S4 wiring of *both* the Fine and Course resolvers.

Chapter 4: Backplane Programming

The 1361 module is programmed over the backplane through the input and output words assigned to it. Because these words are constantly updated, the unit implements a simple hand-shaking protocol to control when it accepts new programming data. This hand-shaking protocol is called a Programming Cycle

Programming Cycle

A Programming cycle consists of six steps and is controlled by the *Transmit Bit* in the output data words and the *Acknowledge Bit* in the input data words.

- a. Write the new programming data into the output data words with the Transmit Bit reset. This step insures that the correct data is in the output data words before the Programming Cycle begins.
- b. Set the Transmit bit. A Programming Cycle is initiated when this bit makes a 0 to 1 transition.
- c. Once the unit is done with the programming data, it will set any necessary error bits and the Acknowledge Bit in its input data words.
- d. Once you see the Acknowledge Bit set, check for any errors. The error bits are only valid while the Acknowledge Bit is set.
- e. Respond to any errors and reset the Transmit Bit.
- f. The 1361 module responds by resetting the Acknowledge Bit. The Programming Cycle is now complete.

EEPROM Parameter Memory

Parameter values are stored in a non-volatile EEPROM memory. This memory type can store parameter values in the absence of power for over twenty years, but you can only write to it a limited number of times before it will be damaged. The EEPROM Memory that AMCI uses is guaranteed for a minimum of 100,000 write cycles.

Every time you have the Reset Position Data bit set during a programming cycle, the 1361 module calculates an offset and stores this value in the EEPROM. If your application requires you to continuously Reset the Position data, consider doing this in the PLC instead of in the 1361 module.

A FAQ showing how to offset the position data in the PLC is located on the following page of our website.
<http://www.amci.com/faqs.asp>

Output Registers: (Data sent from the PLC to the 1361 module)

The 1361 module is configured through 16 %Q bits and four %AQ registers. The function of these bits and words is shown below.

Data Type	Function	Range
%Q Bits	Control Word (see below)	See description below
%AQ register 1	Transducer Type	100, 180, 1000, 1800, or 64
%AQ register 2	Number of Turns	100 Turn: 1, 2, 4, 5, 10, 20, 25, 50 or 100 180 Turn: 1, 2, 3, 4, 5, 6, 9, 10, 12, 15, 18, 20, 30, 36, 45, 60, 90 or 180 1,000 Turn:(Any 100 turn value) * 10 1,800 Turn:(Any 180 turn value) * 10 64 Turn: 1, 2, 4, 8, 16, 32, 64
%AQ register 3	Full Scale Count in Double Precision Integer Format	2 to (# of Turns * 4,096) if AMCI 100 or 180 Turn
%AQ register 4		2 to (# of Turns * 409.6) if AMCI 1000 or 1800 Turn 2 to (# of Turns * 1,024) if Autotech 64 turn transducer

Control Word

Bit 16	Bit 15	Bit 14	Bit 13	Bit 12	Bit 11	Bit 10	Bit 09	Bit 08	Bit 07	Bit 06	Bit 05	Bit 04	Bit 03	Bit 02	Bit 01
Transmit Bit	Clear EEPROM Error	0	0	0	0	0	0	0	0	0	0	0	Direction Bit	Transducer Setup	Reset Position Data

Bit 1: Reset Position Data. Set to force the position data to zero

Bit 2: Transducer Setup Set this bit to program the direction parameter in %Q bit 3 and the Transducer Type, Number of Turns, and Full Scale Count parameters in %AQ words 1 to 4. If this bit is not set, the module will ignore all of the transducer setup parameters. Programming the Transducer Setup clears the internal offset generated by a Reset Position Data operation.

Bit 3: Direction Bit. This bit is only valid when bit 2 is set. Set this bit to “0” to set the direction of increasing counts to Positive. Set this bit to “1” to set the direction of increasing counts to Negative. A Command Error will be generated if this bit is set when the Transducer Setup Bit is not set. **Note: The Count direction parameter is only available on 1361 modules with a serial number of 97974 or above.**

Bits 4 to 14: Reserved Must be set to zero.

Bit 15: Clear EEPROM Error. Set this bit to one to clear an EEPROM Memory Fault.

Bit 16: Transmit Bit. The zero to one transition of this bit initiates a program transfer.



The Internal Offset generated by a Reset Position Data operation will be reset to zero when the Transducer Setup parameters are programmed.

Input Registers (Data sent from the 1361 module to the PLC)

The 1361 module reports its position, velocity, and status information through 16 %I bits and three %AI registers. The function of these bits and words is shown below.

Data Type	Function	Units
%I Bits	Status Word (see below)	See description below
%AI register 1	Position Data in Double Integer Format	Counts
%AI register 2		
%AI register 3	Tachometer Data	Revolutions Per Minute (RPM)

Status Word

Bit 16	Bit 15	Bit 14	Bit 13	Bit 12	Bit 11	Bit 10	Bit 09	Bit 08	Bit 07	Bit 06	Bit 05	Bit 04	Bit 03	Bit 02	Bit 01
Acknowledge Bit	Transducer Fault	0	EEPROM Error	0	0	0	0	Message Ignored	Command Error	0	0	0	Full Scale Count Error	Number of Turns Error	Transducer Type Error

Bit 1: Transducer Type Error. Set when the programmed Transducer Type is not 100, 180, 1000, 1800, or 64.

Bit 2: Number of Turns Error. Set when the programmed Number of Turns for the selected Transducer Type is not valid.

Bit 3: Full Scale Count Error. Set when the programmed Full Scale Count is outside of the range of (2 to (4096 * Number of Turns)) for 100 and 180 turn AMCI transducers, (2 to 409.6 * Number of Turns)) for 1000 and 1800 turn AMCI transducers, and (2 to (1204 * Number of Turns)) for Autotech transducers.

Bit 7: Command Error. Set under four conditions.

- 1) Attempt to program the module while there is an EEPROM error.
- 2) Only the Transmit bit is set in the Control Word.
- 3) %Q bits specified as zero are set to 1.
- 4) Setting the Program Direction bit, %Q3, without setting the Transducer Setup bit, %Q2. This bit will be reset when valid instructions are sent to the module.

Bit 8: Message Ignored: If an error bit is set, the error must be cleared by first programming the affected parameter with valid data. This bit is set, along with the original error bit, if you attempt to program a different parameter before clearing the error. This bit will also be set if an attempt is made to zero the module when there is a transducer fault.

Bit 13: EEPROM Error. Set on an EEPROM memory fault.

Bit 15: Transducer Error. Set when there is a transducer fault. This error bit will clear itself when the module is correctly connected to a compatible resolver.

Bit 16: Acknowledge Bit. Set by the module to acknowledge the receipt of programming data from the processor. The module resets the Acknowledge Bit after the processor resets the Transmit Bit.

Chapter 5: Sample Program

The three rung ladder logic below shows how to program a 1361 module. This example assumes that the 1361 module has been assigned the lowest possible register and bit addresses. The program also uses %R1 to %R5 to store the data that is sent to the 1361 module.

- %R1 = 6 (6 hex) = Bits to copy to %Q1 to %Q16. Programs Transducer Setup and sets the Count Direction to negative
- %R2 = 100 = Transducer Type
- %R3 = 100 = Number of Turns
- %R4 & %R5 = 409600 = Full Scale Count in Double Precision Integer Format

Bit %M00017 is used to initiate a Programming Cycle. When this bit is set, either manually or by the ladder logic program, and the Acknowledge Bit (%I00016) from the 1361 module is not set, copy the data stored in %R1 to Control Word Bits %Q00001 and the four words of programming data, starting at %R2, into the data words %AQ1 to %AQ4. Please note that bit 16 of %R1, which is copied to the Transmit bit of the 1361 module, is not set.

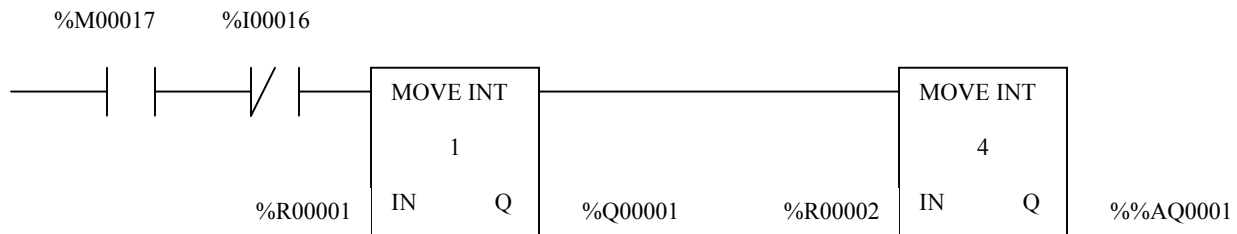

As long as a Programming Cycle is initiated, and the 1361 module has not responded by setting its Acknowledge Bit, set the Transmit Bit %Q00016.

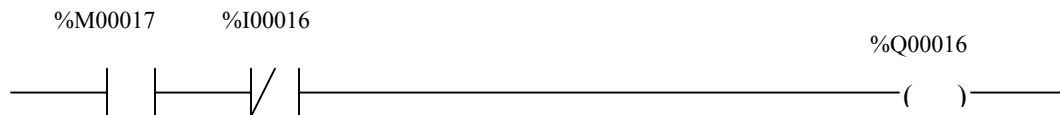

Once the 1361 module responds by setting its Acknowledge bit (%I00016) terminate the Programming Cycle by resetting (%M00017), the bit that initiated the Programming Cycle.



Chapter 6: Specification Revision History

Revision 0.0 was created on 1/25/06 and replaces manual 1361-295M.