



3202 Rev A Module Specifications

Two Channel ControlLogix Stepper Module

Revision 4.0

The 3202 module is a two-axis stepper controller that occupies one slot in a ControlLogix rack. This unit receives profile data from the PLC and outputs Step and Direction signals or Clockwise/Counter Clockwise pulses to a stepper driver. Inputs on the module allow homing and emergency stop operations.

Differential incremental encoders can be attached to the unit to provide feedback information.

The 3202 uses sixteen 32 bit input words and sixteen 32 bit output words. The two channels are totally independent from each other and can be configured and programmed to perform different operations.

Because the 3202 module does not use a non-volatile memory, it must be configured at every power up.

Sample programs showing how to program the 3202 module are available from the following page of our website.

<http://www.amci.com/sampleprograms.asp>

General Information

Important User Information

The products and application data described in this manual are useful in a wide variety of different applications. Therefore, the user and others responsible for applying these products described herein are responsible for determining the acceptability for each application. While efforts have been made to provide accurate information within this manual, AMCI assumes no responsibility for the application or the completeness of the information contained herein. Throughout this manual the following two notices are used to highlight important points.

WARNINGS tell you when people may be hurt or equipment may be damaged if the procedure is not followed properly.

CAUTIONS tell you when equipment may be damaged if the procedure is not followed properly. No patent liability is assumed by AMCI, with respect to use of information, circuits, equipment, or software described in this manual. The information contained within this manual is subject to change without notice. UNDER NO CIRCUMSTANCES WILL ADVANCED MICRO CONTROLS, INC. BE RESPONSIBLE OR LIABLE FOR ANY DAMAGES OR LOSSES, INCLUDING INDIRECT OR CONSEQUENTIAL DAMAGES OR LOSSES, ARISING FROM THE USE OF ANY INFORMATION CONTAINED WITHIN THIS MANUAL, OR THE USE OF ANY PRODUCTS OR SERVICES REFERENCED HEREIN.

Standard Warranty

ADVANCED MICRO CONTROLS, INC. warrants that all equipment manufactured by it will be free from defects, under normal use, in materials and workmanship for a period of [18] months. Within this warranty period, AMCI shall, at its option, repair or replace, free of charge, any equipment covered by this warranty which is returned, shipping charges prepaid, within one year from date of invoice, and which upon examination proves to be defective in material or workmanship and not caused by accident, misuse, neglect, alteration, improper installation or improper testing. The provisions of the “STANDARD WARRANTY” are the sole obligations of AMCI and excludes all other warranties expressed or implied. In no event shall AMCI be liable for incidental or consequential damages or for delay in performance of this warranty.

Returns Policy

All equipment being returned to AMCI for repair or replacement, regardless of warranty status, must have a Return Merchandise Authorization number issued by AMCI. Call (860) 585-1254 with the model and serial numbers along with a description of the problem. A “RMA” number will be issued. Equipment must be shipped to AMCI with transportation charges prepaid. Title and risk of loss or damage remains with the customer until shipment is received by AMCI.

24 Hour Technical Support Number

Technical Support, in the form of documents, FAQs, and sample programs, is available from our website, www.amci.com. 24 Hour technical support is also available on this product. For technical support, call (860) 583-7271. Your call will be answered by the factory during regular business hours, Monday through Friday, 8AM - 5PM EST. During non-business hours, an automated system will ask you to leave a detailed message and the telephone number where you can be reached. The system will page an engineer on call. Please have your product model number and a description of the problem ready before you call.

Table of Contents

Installing the 3202 Module	Chapter 1	4
	Installing the 3202 module	4
	Configuring a ControlLogix system	4
	Module Specifications	5
	Discrete Input Specifications	6
	Front Panel & LED Functions	7
	Output Signals	7
	Connector Pinout and Wiring Notes	8
	Diagnostic Feedback Wiring	9
	Differential Output Wiring	9
	Single Ended Encoder Wiring	10
Calculating Move Profiles	Chapter 2	11
Configuration Programming	Chapter 3	13
	Configuration Bits	15
	Input Active Level	15
	Starting Speed	16
	Invalid Configurations	16
	Configuration Mode Input Data	17
Command Mode Operations	Chapter 4	18
	Absolute & Relative Moves	18
	Hold Move	19
	Resume Move	19
	Immediate Stop	19
	Find Home +/(CW), Find Home -/(CCW)	20
	Manual Move +/(CW), Manual Move -/(CCW)	23
	Preset Current Position	24
	Preset Encoder Position	24
	Reset Errors	24
	Blend Move	25
	Encoder Move	26
	Diagnostic Feedback	26
	Acceleration Types	27
Command Mode Output Data	Chapter 5	28
	Command Words	28
	Command Bits	29
	Blend Move Programming (message instructions)	30
Command Mode Input Data	Chapter 6	33
	Status Bits	33
	Input Word Functions	34
	Status & Error Bit Functions	35
Revision History		38

Chapter 1: Installing the 3202 module

The 3202 can be installed in any ControlLogix module slot as long as power supply requirements are met. The 3202 module requires 510mA from the 5Vdc supply to operate.

1. Align the module's circuit board with the top and bottom card guides in the rack.
2. Gently slide the module into the rack until the top and bottom latches secure the module in place.

To remove the module, depress the top and bottom latches and slide the module out of the rack.

Note➤ The ControlLogix backplane is hot-swappable. That is, the 3202 module can be inserted and removed under power.

Configuring the ControlLogix system for the 3202 module

1. Open RSLogix 5000 and the project in which you want to install the AMCI 3202 module.
2. Right click on I/O Configuration in the Project Tree.
3. Select New Module.
4. Select the following module type and description from the list that appears.

Type = 1756-MODULE

Description = Generic 1756 Module (This module will appear as an Unknown Device when viewed from RSNetworkx)

Click on OK.

5. Enter the following module properties.

Name: *Your Choice* (must begin with a letter)

Description: *Your Choice*

Comm Format: *Data-DINT* (must be Data-DINT)

Slot: *location of 3202 module*

6. Enter the Connection Parameters from the following table. (The Listen Only columns will only be used by any additional processors that are installed in the rack chassis.)

CONNECTION PARAMETERS

	Owner Controller		Listen Only	
	Assembly Instance	Size in 32 bit words	Assembly Instance	Size in 32 bit words
INPUT	100	16	101	16
OUTPUT	194	16	195	1
CONFIGURATION	242	0	2	0

7. Click on Next >
8. Set the RPI (Rate Packet Interval) Time to the desired value. 5ms is the recommended value. The minimum RPI is 0.5ms. However, below 3ms, the unit may occasionally lose communication with the PLC.
9. Click on Finish >>

The 3202 module will now appear in the project tree and three new data tags will have been created, Local:X.I.Data[Y], Local:X.O.Data[Y] and Local:X.C.Data[Y] where “X” is the slot number and “Y” is the word number. The status, current position, encoder position, and captured encoder value are located in the Input tags. With the exception of the programming of the blend move profile, which uses a message instruction; all commands are sent to the 3202 module through the Output tags. The 3202 module does not use the Configuration tags.

Module Specifications

- Backplane Current Draw: 510mA @5Vdc
- Throughput Time: 250 μ s
(Inputs must be on for 250 μ s to be scanned by the module)
- Minimum recommended RPI time = 3ms

Stepper Outputs

- 5V differential (3.5V to 4Vdc peak typical)
- Maximum Output Current: 20mA
- Maximum Output Frequency: 1MHz

Encoder Inputs

- 5V differential encoder only
- A, B, and Z Maximum Input Current: 10mA per channel @5Vdc
- A, B, and Z Maximum Input Frequency with X4 decoding = 1MHz
- The 3202 module uses X4 decoding on the encoder signals. Only a 5V differential encoder can be directly attached to each channel of the 3202 module. Encoders at other voltage levels can be connected if current limiting resistors are used.
- A move profile does not have to be in progress in order for the unit to count encoder pulses.
- The A and B signals must both be connected to the 3202 module to have the encoder data increment or decrement.
- Because X4 decoding is used, the maximum frequency of the A and B signals is 250kHz.
- When used for Diagnostic Feedback, the encoder inputs have a maximum input frequency of 500kHz.

Discrete Inputs

- Input Type: Sinking
- Input Voltage Range: On = 8 to 24Vdc
Off = 0 to 2Vdc
- Input Current: 15mA @ 24Vdc
- Response Time (On and Off): 5 μ s
- The module interrogates the Discrete Inputs a maximum of every 250 μ s.
- The Input Functions are described below

Capture Input

With version 3.1 or later firmware, the inactive to active transition of this input will cause either the current encoder data or the current position data to be captured and placed in the input registers. With version 2.2 or earlier firmware, only the current encoder can be captured. In either case, this value will remain until the next inactive to active transition of the input.

External Input

When this input becomes active during a move operation, the stepper motor will decelerate and stop, while keeping track of the current position. During a Manual Move, the External Input will initiate a controlled stop. During an Absolute or Relative move, the External Input will cause the module to make a controlled stop to a hold state.

If the External Input is active when a move operation is initiated, the 3202 module will generate only one step in the specified direction.

Emergency Stop

The Emergency Stop Input causes the current move operation to stop without any deceleration. The pulse signal is simply stopped. If the channel was moving when this command was issued, the current position will become invalid, and the Position Invalid Input Bit will be set. The channel will have to be Preset or Homed again before an Absolute Move operation can be performed. However, it will be possible to perform a Relative or a Manual Move after the Emergency Stop Input has been used.

Home Input

Reaching the Home Input during a homing operation will cause the 3202 module to reset both the Current Position, and if applicable the Encoder Position, to zero. The Home Input has no function unless a homing operation is being performed.

Each channel of the 3202 module must be configured with the ability to home the module. This is true even if your system does not require a Home Input.

CW & CCW Limit Switch Inputs

During most move operations, the CW and CCW Limit Switches act as an Emergency Stop input. There are two exceptions. The first is during a homing operation, where the direction of motion will be reversed and the module will start looking for the Home Input in the opposite direction. The second is if the opposite end limit switch is reached during a Manual Move operation. For example if the CW limit switch is reached during a CCW Manual Move. In this case the module will ignore the End Limit Switch input.

Each channel of the 3202 module must be configured with at least one of these Limit Switch Inputs.

Front Panel

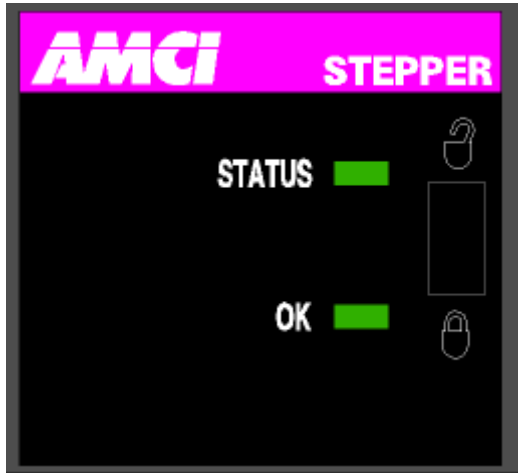

LED Function

Status LED (Listed by priority)

- Solid Red: Module failed power up diagnostics
- Blinking Red: Configuration Error, Command Error, Input Error, Home Invalid Error, or an Invalid Profile Error. Set when error detected on either channel.
- Blinking Green: Motion on either channel
- Solid Green: Module OK, no motion in progress, at least one channel configured
- Off: Both channels disabled

OK LED

- Solid Red: Module Fault
- Blinking Red: Communication between module and PLC interrupted
- Blinking Green: PLC is in Program Mode or one way communication, module only sends data to the PLC, or slot is not correctly configured for the module
- Solid Green: Module Owned, two way communication

Output Signals

The 3202 module can be programmed to output either Step and Direction signals or CW / CCW steps. There is no advantage to either type; you must simply configure each channel of the 3202 module to match the input type of your driver. The two signals types are illustrated below.

Step and Direction Output

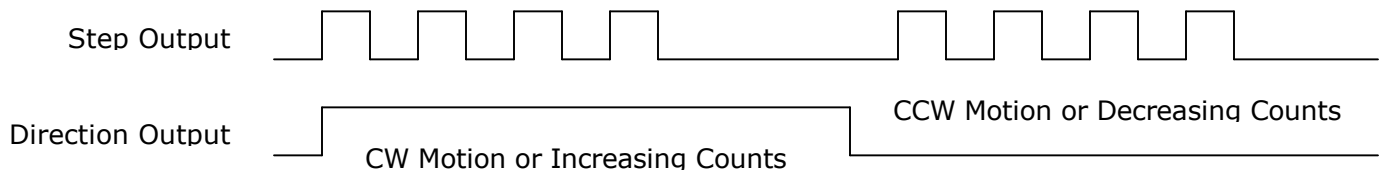

CW and CCW Step Outputs



Connector Pin Out:

The input connector consists of a Removable Terminal Block with the Rockwell Automation Part Numbers 1756-TBCH (36 position cage clamp) or 1756-TBS6H (36 position spring clamp). **The terminal block is not supplied with the 3202 module.**

Channel 1 +A Encoder Input	2	○ ○	1	Channel 2 +A Encoder Input
Channel 1 -A Encoder Input	4	○ ○	3	Channel 2 -A Encoder Input
Channel 1 +B Encoder Input	6	○ ○	5	Channel 2 +B Encoder Input
Channel 1 -B Encoder Input	8	○ ○	7	Channel 2 -B Encoder Input
Channel 1 +Z Encoder Input	10	○ ○	9	Channel 2 +Z Encoder Input
Channel 1 -Z Encoder Input	12	○ ○	11	Channel 2 -Z Encoder Input
Chassis Ground (shields)	14	○ ○	13	Chassis Ground (shields)
Channel 1 +Step or +CW Output	16	○ ○	15	Channel 2 +Step or +CW Output
Channel 1 -Step or -CW Output	18	○ ○	17	Channel 2 -Step or -CW Output
Channel 1 +Dir. or +CCW Output	20	○ ○	19	Channel 2 +Dir. or +CCW Output
Channel 1 -Dir. or -CCW Output	22	○ ○	21	Channel 2 -Dir. or -CCW Output
Channel 1 Capture Input	24	○ ○	23	Channel 2 Capture Input
Channel 1 External Input	26	○ ○	25	Channel 2 External Input
Channel 1 Home Input	28	○ ○	27	Channel 2 Home Input
Channel 1 Emergency Stop Input	30	○ ○	29	Channel 2 Emergency Stop Input
Channel 1 CW Limit Switch	32	○ ○	31	Channel 2 CW Limit Switch
Channel 1 CCW Limit Switch	34	○ ○	33	Channel 2 CCW Limit Switch
Module Common	36	○ ○	35	Module Common

Wiring Notes

- The 3202 module uses a DS26LS31 differential line driver in series with a 10Ω resistor for the stepper (+/- step and +/- direction) outputs.
- Stepper signals are generally low voltage, low power signals. If you are using A-B guidelines for cabling installation, treat the cable as a Category 2 cable. It can be installed in conduit along with other low power cabling such as communication cables and low power ac/dc I/O lines. It cannot be installed in conduit with ac power lines or high power ac/dc I/O lines.
- To reduce or eliminate the influence of electrical noise on the system, the step and direction cable shields must be connected to chassis ground terminals 13 or 14. Also, the shields must be connected to only one end of the cable run and treated as conductors at any junctions. Do not ground the shields at the junction box.
- If the signal cable must cross power feed lines, it should do so at right angles.
- Route the cable at least five feet from high voltage enclosures, or sources of “rf” radiation.
- The Module Common terminals must be connected to the COM of the supply that powers the discrete inputs. A Stepper Driver with Single Ended Step and Direction inputs can also be referenced here.
- The Chassis Ground pin is connected to the PLC’s chassis ground.

Diagnostic Feedback Wiring

	Pin Numbers	Signal Names
Channel 1	16 to 2	+Step to +A
	18 to 4	- Step to -A
	20 to 6	+Direction to +B
	22 to 8	-Direction to -B
Channel 2	15 to 1	+Step to +A
	17 to 3	- Step to -A
	19 to 5	+Direction to +B
	21 to 7	-Direction to -B

Differential Wiring Diagram

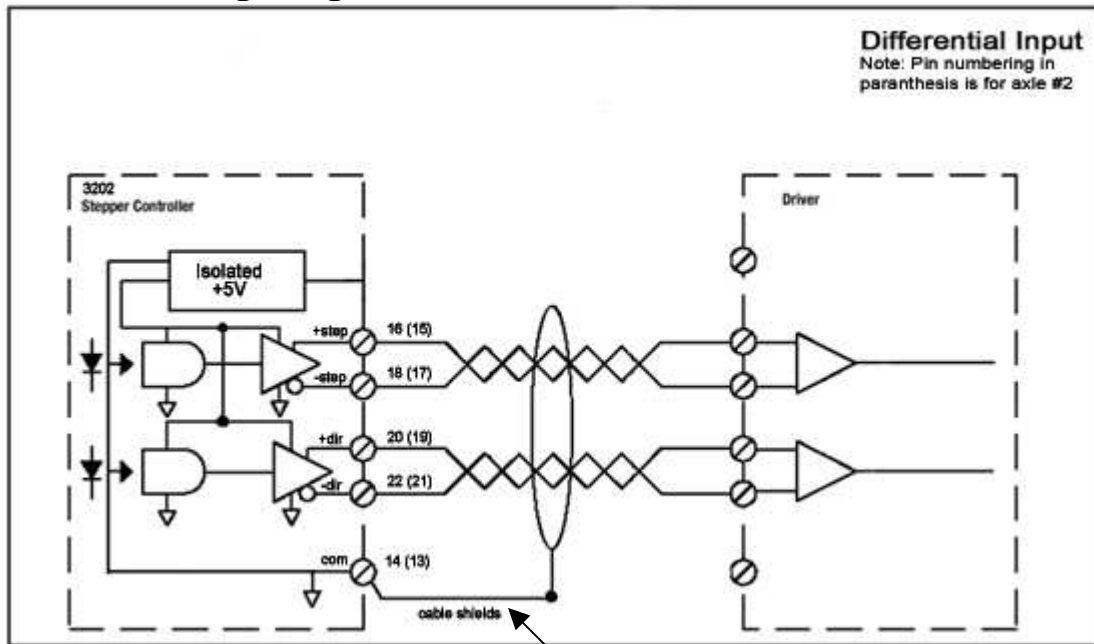

The pulse and direction cable shields must be connected to chassis ground input pins 13 and 14

Single Ended Encoder Wiring

The 3202 module is designed to work with +5Vdc differential encoders. Use the following table and diagrams to attach single ended encoders to the 3202 module. A current limiting resistor R_{Lim} must be installed for encoders that do not operate at 5Vdc.

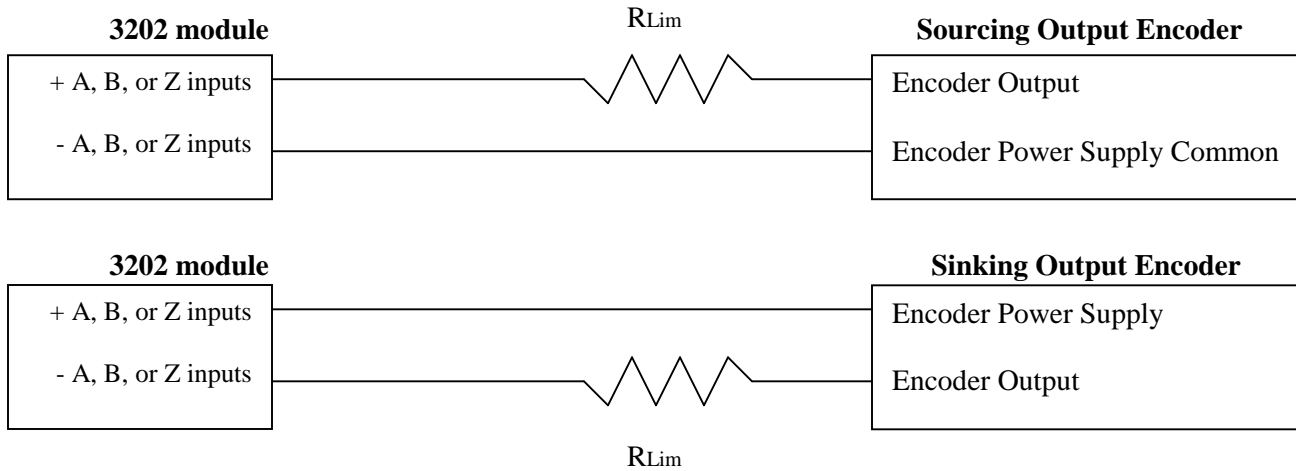

Encoder Power Supply	Current Limiting Resistor R_{Lim}
5Vdc	none
12Vdc	1K Ω
15Vdc	1.2K Ω
24Vdc	2.7K Ω

Chapter 2: Calculating Move Profiles

Before starting a move operation, the 3202 module completely calculates each portion of the move profile. That is, it calculates how many steps of the move profile will be required for acceleration and how many steps will be required for deceleration. Depending on the data used to define the move profile, this can result in two types of velocity profiles, either a *Trapezoidal Profile* or a *Triangular Profile*.

A *Trapezoidal Profile* jumps from rest to the Starting Speed, accelerates to the Programmed Velocity at the commanded acceleration rate, continues at the Programmed Velocity to a predetermined point, and then decelerates to the target position at the commanded deceleration rate to the starting speed and stops.

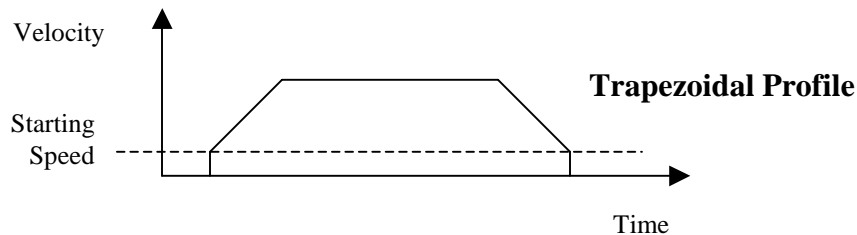

However, if the length of a commanded move is not long enough to attain the programmed velocity before the deceleration point is reached, a *Triangular Velocity* profile will be generated.

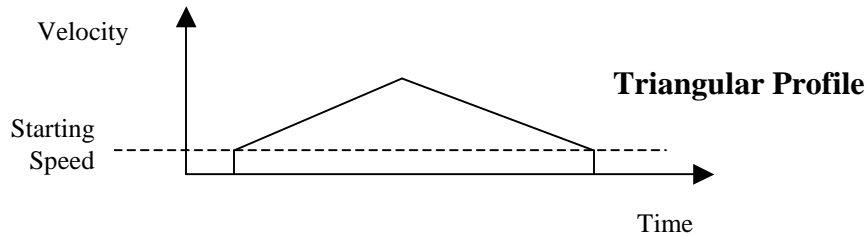

Regardless of the type of Velocity Profile that is being run, the following equations can be used to determine both the time to accelerate and the number of steps needed to accelerate. These formulas can also be used to calculate the time and distance to decelerate.

$$T_a = (V_s - V_o)/a$$

$$D_a = T_a * (V_o + V_s)/2$$

- V_o = Starting Speed (steps/second)
- V_s = Programmed Speed (steps/second)
- T_a = Time to accelerate (seconds)
- D_a = Distance to accelerate (steps)
- a = Acceleration rate (steps/second/second)

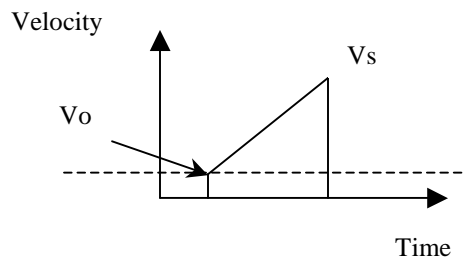

Calculation Notes

1. The acceleration and deceleration values sent to the 3202 module as part of the move profile have units of steps/second/second.
2. The acceleration and deceleration values have a minimum value of 1,000 steps/second/second and a maximum of 2,000,000 steps/second/second.
3. If the number of steps to accelerate plus the number of steps to decelerate is greater than the number of steps programmed in the target position registers, then the 3202 module will run a *Triangular Velocity Profile*.
4. If the number of steps to accelerate plus the number of steps to decelerate is less than the number of steps programmed in the target position, then the 3202 module will run a *Trapezoidal Velocity Profile*.

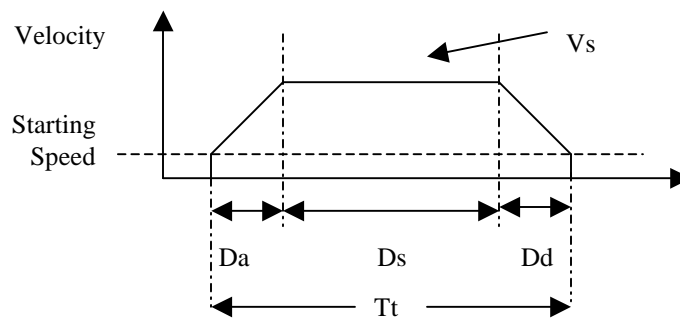

$$D_s = (\text{Total Number of Steps}) - (D_a + D_d)$$

$$T_t = T_a + T_d + D_s/V_s$$

D_a = Distance to Accelerate (steps)

D_s = Distance at the programmed speed (steps)

D_d = Distance to decelerate (steps)

V_s = Programmed Speed (steps/sec)

T_t = Total Profile Time (seconds)

Starting Speed

The starting speed has a range of 1 to 1,000,000 pulses/sec and is the pulse frequency at which every move begins and ends. That is, the first and last pulses of the move profile will be at the starting speed. Some portions of the homing operations are also performed at the starting speed.

The Starting Speed can be any value less than or equal to the programmed speed of the slowest move. Although it is not necessary, the smoothest transition from rest to the programmed speed will be achieved with a Starting Speed equal to the square root of the acceleration value.

You may have the starting speed set to too small a value if you have a larger than expected delay between two of your move operations. For example, a starting speed of 1 step per second will result in a 1 second delay between move operations.

Chapter 3: Configuration Programming

The Configuration Mode provides the ability to select the proper setup configuration to match the stepper application without having to set any switches. The configuration file, consisting of two 32 bit words on each channel, allows the following parameters to be defined.

1. If a CW Limit Switch will be used and its input active state
2. If a CCW Limit Switch will be used and its input active state
3. If an Emergency Stop will be used and its input active state.
4. If an External Input will be used and its active state.

The External Input can be used to stop a Manual Move operation, or to place an Absolute or Relative move in a hold state.

If the External Input is active when a move operation is initiated, the 3202 module will generate only one step in the specified direction.

5. If the Capture Input will be used and its active state.
6. If a Home Limit Switch will be used and its input active state.
7. If a Quadrature Encoder will be used with the system
8. If the channel will be configured for Diagnostic Feedback. Diagnostic Feedback allows the unit to count its own output pulses by wiring the outputs to the encoder inputs.
9. The output type, either CW and CCW Pulses or Pulse and Direction.
10. The type of homing operation that will be performed. There are four Homing possibilities.

1. Home Limit Switch Only
2. Home Limit Switch with a backplane bit acting as a Home Proximity.
3. Marker Pulse Home with the Home Limit Switch Input acting as a Home Proximity.
4. Marker Pulse Home with a backplane bit acting as a Home Proximity.

Note 1: When configured to use a Proximity Input, the 3202 module will ignore any other home inputs until the proximity input is detected.

Note 2: The Backplane Proximity bit is a set by the PLC to indicate to the 3202 module that you are nearing the location of either the Home Limit Switch or the encoder's Marker Pulse.

Note 3: The Marker Pulse option also requires the presence of the Quadrature Encoder.

11. The Starting Speed. The starting speed is the pulse frequency that every move begins and ends at. Some portions of the homing operations are also performed at the starting speed.

Configuration Mode Consumed Data (Sixteen 32 bit words sent from the PLC to the 3202 module)

While in configuration mode, the output registers have the following format.

32 bit output Word	Channel	Configuration Output Data	Units	Range
0	1	Configuration Bits		See description below
1	1	Starting Speed	Steps / Second	1 to 1,000,000
2	1	0		Must be zero
3	1	0		Must be zero
4	1	0		Must be zero
5	1	0		Must be zero
6	1	0		Must be zero
7	1	0		Must be zero
8	2	Configuration Bits		See description below
9	2	Starting Speed	Steps / Second	1 to 1,000,000
10	2	0		Must be zero
11	2	0		Must be zero
12	2	0		Must be zero
13	2	0		Must be zero
14	2	0		Must be zero
15	2	0		Must be zero

Note 1: At power up, both channels will be disabled. They will remain disabled as long as configuration data is not written to the module.

Note 2: If Configuration Mode is entered while a move is occurring, the Command Error bit will be set, the move will run to completion, and then the module will enter Configuration Mode.

Configuration Bits

Bit 0: set when the Capture Input will be used. With version 3.1 or higher firmware, the Capture Input can be used in two ways.

1. Using the Capture Input without the Quadrature Encoder will capture the Current Position Data.
2. Using the Capture Input with the Quadrature Encoder will capture the Encoder Data.

Bit 1: set when an External Input is used. The external input can be used to stop a Manual Move operation, or to place an Absolute or Relative move in a hold state.

Bit 2: set when a Home Limit Switch Input will be used.

Bit 3: set when the Emergency Stop Input will be used

Bit 4: set when a CW Limit Switch will be used

Bit 5: set when a CCW Limit Switch will be used

Even if they are not required by your application, the ability to home the module and at least one end limit switch must exist in the configuration data. If this is true in your system, set bits 2, 4, 5, 18, 20, and 21. This configures the module for all of the inputs and sets the active state to active high. Simply do not wire anything to the input terminals and the inputs will be ignored.

Bit 6: set for backplane Home Proximity operations

Bit 7: reserved for future use

Bit 8: set when Quadrature encoder will be used

Bit 9: set when diagnostic feedback will be used

Bit 10: “1” when output pulse type is pulse train and direction

“0” when output pulse type is CW pulse train and CCW pulse train

Bit 11: reserved for future use

Bit 12: “0” for limit switch home operations

“1” for marker pulse home operations

Bits 13 to 15: reserved for future use

Bit 16: determines the active level of the Capture Input

Bit 17: determines the active level of the External input

Bit 18: determines the active level of the Home Limit Switch input

Bit 19: determines the active level of the Emergency Stop input

Bit 20: determines the active level of the CW Limit Switch

Bit 21: determines the active level of the CCW Limit Switch

Bits 22 to 27: Reserved for future use

Bit 28: Set to disable the channel

Bits 29 and 30: Reserved for future use

Bit 31: “1” for configuration mode operations, “0” for command mode operations

Input Active Level

Defines the active level of the inputs. These bits will be set for high level active or Normally Open (NO), or reset for low level active or Normally Closed (NC). Please note that the active level of the inputs is taken into account only when the input has been defined as being used.

Starting Speed

The starting speed has a range of 1 to 1,000,000 pulses/sec and is the pulse frequency at which every move begins and ends. Some portions of the homing operations are also performed at the starting speed.

Note: The Starting Speed can be any value less than or equal to the programmed speed of the slowest move. Although it is not necessary, the smoothest transition from rest to the programmed speed will be achieved with a Starting Speed equal to the square root of the acceleration value.

You may have the starting speed set to too small a value if you have a larger than expected delay between two of your move operations. For example, a starting speed of 1 step per second will result in a 1 second delay between move operations.

Invalid Configurations

The 3202 module will not accept all possible configurations. The following is a list of the invalid configurations:

1. A configuration without the ability to home the module.
2. A configuration without at least one End Limit Switch, either CW or CCW.

Note: The ability to home the module and at least one of the end limit switches have to be configured. They do not have to actually be used in the stepper application.

3. Using Quadrature Encoder and Diagnostic Feedback.
4. Using a Marker Pulse Home without the Quadrature Encoder.
5. Diagnostic Feedback with CW and CCW pulse outputs.
6. A starting speed outside the range of $1 \leq \text{starting speed} \leq 1,000,000$.
7. Setting the module to use the Capture Input without configuring the module to use the encoder. (Firmware versions 2.2 or lower. Firmware versions 3.1 or higher do not have this restriction.)
8. Setting any of the unused bits in the configuration words.
9. Selecting Marker Pulse home without also selecting to use either the Home Input, which will act as a proximity limit, or the Backplane Proximity bit.
10. Selecting Marker Pulse home with both the Home Input and the Backplane Proximity bit.
11. Setting any of the unused words to a value other than zero.

The 3202 has to be configured before starting any operations. When the Configuration Mode bit is set in the output registers, the stepper controller enters Configuration Mode. When in this mode, the stepper controller will stop its operations and set the Configuration Mode status bit in the input registers. It then waits for the configuration file to be transferred. If there is no current Configuration File present or if the transferred Configuration File is not valid, the Configuration Error Input bit will be set. If the transferred configuration file is accepted, and if it is different from the current configuration, the configuration data will be mirrored in the input registers.

Configuration Mode Input Data

While in configuration mode, the input registers will mirror the configuration data that was sent to the 3202 module in the output registers. The exceptions are the Module OK bit, status bit 30, the Channel Disabled bit, status bit 28, and the Configuration Error bit, status bit 13.

32 bit Input Word	Channel	Configuration Input Data
0	1	Mirror of Configuration Bits
1	1	Mirror of Starting Speed
2	1	0
3	1	Bits 16 to 31 = Major Revision, Bits 0 to 15 = Minor Revision
4	1	0
5	1	0
6	1	0
7	1	0
8	2	Mirror of Configuration Bits
9	2	Mirror of Starting Speed
10	2	0
11	2	Bits 16 to 31 = Major Revision, Bits 0 to 15 = Minor Revision
12	2	0
13	2	0
14	2	0
15	2	0

Chapter 4: Command Mode Operations

The following is a description of the various commands that the module accepts and the operations that it will perform while in Command Mode. When switching from Configuration Mode to Command Mode, the position will be invalid and the Current Position will be zero.

Absolute/Relative Move

The current position must be valid in order to perform an ABSOLUTE MOVE. A HOME or PRESET operation will have to be performed before the position becomes valid. The distance moved, that is the number of pulses issued by the 3202, is equal to the difference between the Target Position and the Current Position. For example, if the Current Position is 5000, and the Target Position is 7500, then the unit will output 2500 pulses. After the Absolute Move has been completed, the Current Position will be 7500. The direction of motion of an Absolute Move is determined by the relationship between the Current Position and Target Position. If the Target Position > Current Position, then CW motion will occur. If the Target Position < Current Position, then CCW motion will occur.

The current position does not have to be valid to perform a RELATIVE MOVE. The Target Position defines the distance, in number of pulses, to travel relative to the Current Position. For example, if the Current Position is 5000 and the Target Position is 7500, then the unit will output 7500 pulses. After the Relative Move has been completed, the Current Position will be 12,500. The direction of motion of a Relative Move is selected by the sign of the Target Position. A positive Target Position will generate a CW move while a negative Target Position will generate a CCW move.

The ABSOLUTE or RELATIVE MOVE operations can produce two different velocity profiles. Normally the move operations start at the Starting Speed, accelerate to the Programmed speed at the defined acceleration rate, continue at the Programmed speed until it is time to decelerate back to the Starting Speed, and Stop. This generates a trapezoidal velocity profile.

However, if the move operation does not reach the Programmed speed by the time the deceleration is to begin, the move is decelerated to the Starting Speed and Stopped. In this way a triangular velocity profile is generated.

If the move operation runs to completion without error, the MOVE COMPLETE FLAG is set. If an error does occur, the MOVE COMPLETE FLAG will not be set, and an error flag will be set. The Move Complete status bit will be reset at the beginning of the next move operation.

It is possible to hold both Absolute or Relative moves either by issuing a backplane Hold Command or activating the External Input. If the External Input is active when the Absolute or Relative move is initiated, you will get one step in the specified direction before the 3202 module goes into a hold state.

Hold Move

The HOLD MOVE command causes the move operation to decelerate at the programmed deceleration rate to the Starting Speed and stop. When this operation is successfully completed, the module will set the Hold State Input status bit. You have two options while the 3202 module is in a Hold state. Either the Resume Move command can be issued, with or without changing the velocity, acceleration, or deceleration parameters, or an entirely new move profile can be sent to the 3202 module.

Note 1: Only the Hold Move bit must be set in the Command Word. A Command Error will be generated, and the Hold Command ignored, if any other command bits set at the same time.

Note 2: Because the module is already decelerating, it will ignore a Hold Move command issued during the deceleration part of the profile.

Note 3: A Blend Move cannot be held. If a Hold Move command is issued during a Blend Move operation, the module will generate a command error, motion will continue until the blend move is complete, when the Command Error bit will be reset.

Note 4: A Hold Move command issued during an Encoder Move operation will be ignored.

Note 5: A Hold Move command issued during a manual move generates a command error and will cause a controlled stop. The position will not become invalid.

Note 6: Issuing a Hold Command during a Homing operation will cause a command error to be immediately generated, but the home operation will run to completion.

Resume Move

The RESUME MOVE command resumes a previously held Absolute or Relative Move. If the Resume Move command is the first one issued after a Hold Move operation, and no errors have occurred, motion will start from the point where it was stopped. The Hold State status bit will also be reset. If Triangular S Curve or Trapezoidal S Curve acceleration is required, the appropriate acceleration type bit(s) must be set at the same time the Resume Move bit is set. When the move operation has been successfully completed, the Move Complete Flag will be set.

A move operation can be held and resumed many times until one of the following has occurred:

- The move reaches its programmed target position
- An error condition has occurred
- Some other command is issued

Immediate Stop

The Immediate Stop command causes the current move operation to stop without any deceleration. The step signal is simply stopped. If the channel was moving when this command was issued, the current position will become invalid, and the Position Invalid Input Bit will be set. The channel will have to be Preset or Homed again before an Absolute Move operation can be performed. However, it will be possible to perform a Relative Move or a Manual Move after an Immediate Stop command has been issued. There will be no changes to the Status Bits if the Immediate Stop command is issued when motion was not occurring.

Find Home +/(CW), Find Home -/(CCW)

There are four homing options available. They are,

- Home Limit Switch Only
- Home Limit Switch with a backplane Home Proximity bit.
- Marker Pulse Home with the Home Limit Switch Input acting as a Home Proximity.
- Marker Pulse Home with a backplane Home Proximity bit.

When the homing operation is complete, the 3202 will set the At Home input bit, and then reset both the current position and the encoder position to zero. If the capture value is present, it too will be reset to zero.

The Find Home commands require that at least one End Limit Switch, either CW or CCW, be configured. The 3202 will not accept a Find Home +/(CW) command when there is no CW Limit Switch configured. Likewise, it will not accept a Find Home -/(CCW) command when there is no CCW Limit Switch configured. If either of these operations are attempted, the COMMAND ERROR Input bit will be set.

S-Curve acceleration profiles are not allowed during a homing operation. Initiating a home operation with S curve accelerations will cause a command error to be generated.

If, during a Home operation, either of the End Limit Switch endpoints are reached, the module will stop outputting pulses (essentially an emergency stop), wait for two seconds, reverse direction, and start searching for the appropriate homing signal again. It is important not to have the velocity set to high during a homing operation. The sudden stop and change in direction at high speeds may cause the motor to lock up.

The following diagrams illustrate the different homing options.

Home Limit Switch Only

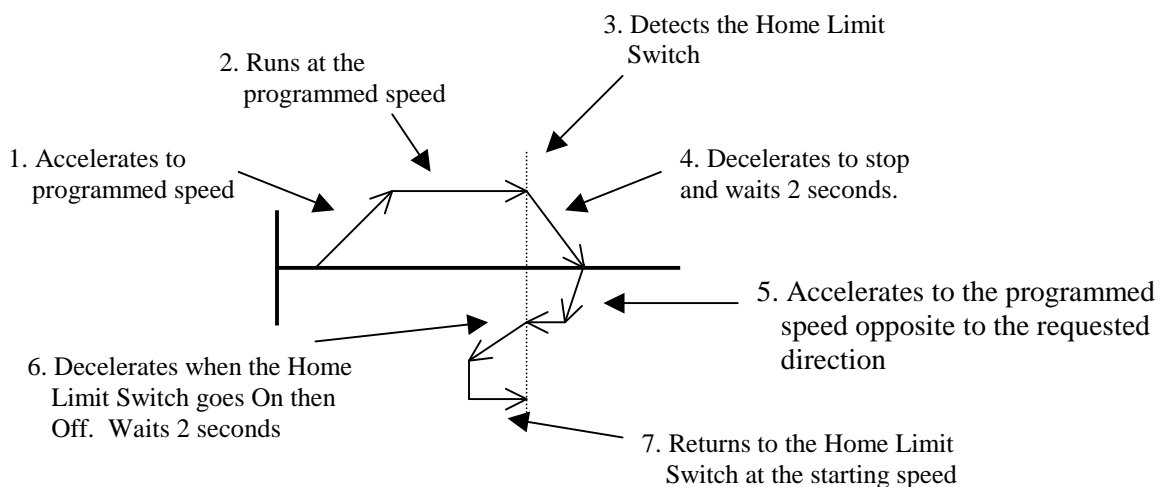

Backplane Home Proximity Bit with Home Limit Switch

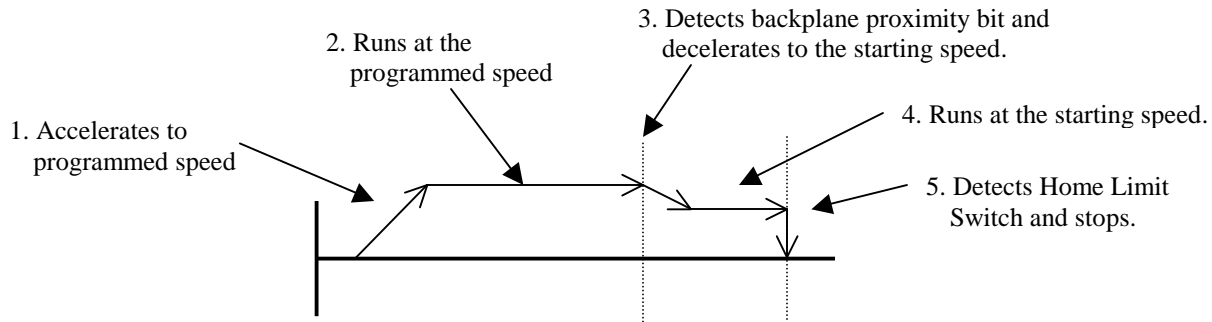

Marker Pulse and Proximity Switch (Either backplane bit or the Home Limit Switch treated as a Proximity Switch)

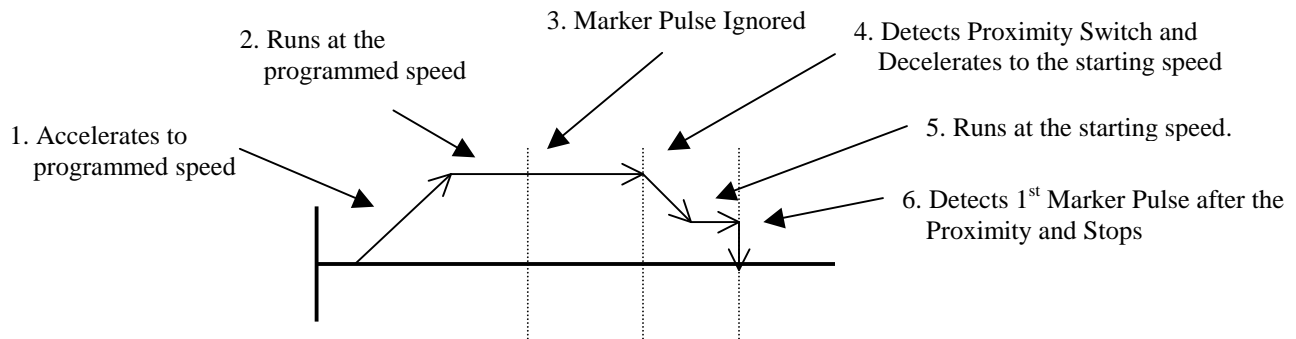

Reaching an End Limit Switch during a Homing Operation

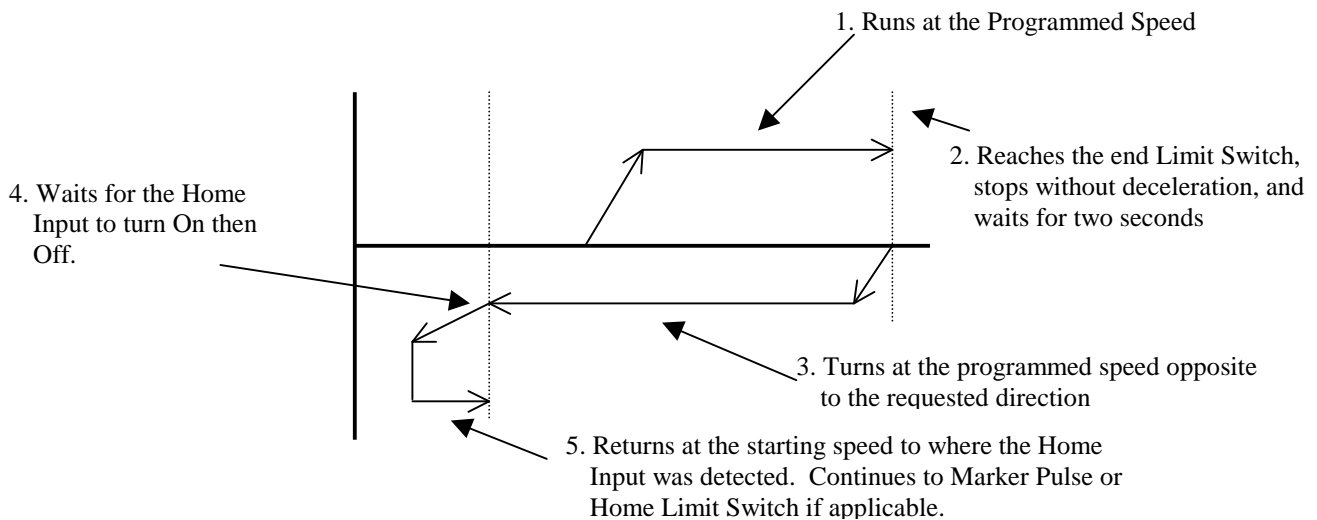

Note: The Home Input shown above can be either the Home Limit Switch or the Backplane Proximity bit.

Home Limit Switch Active when the Home Command is issued

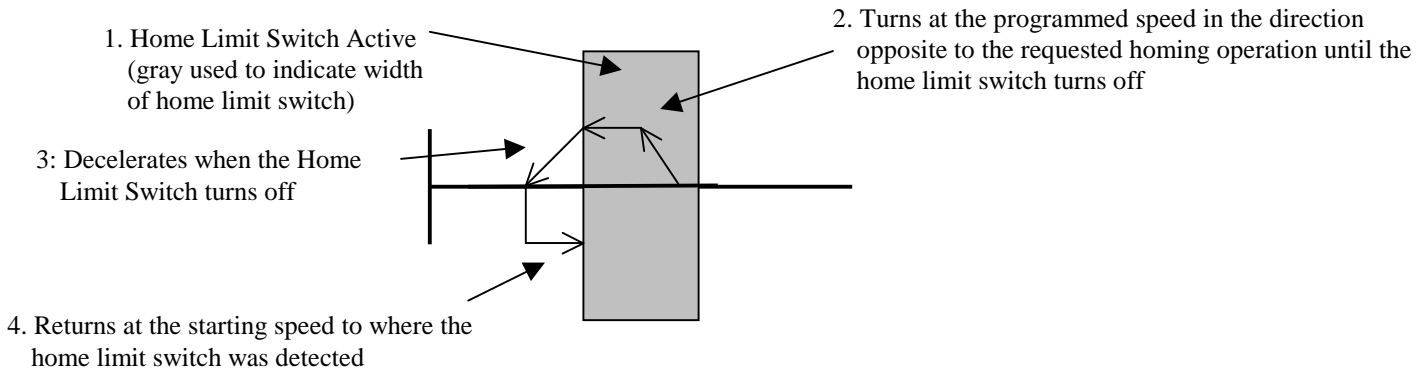

End Limit Switch Active when the Home Command is issued

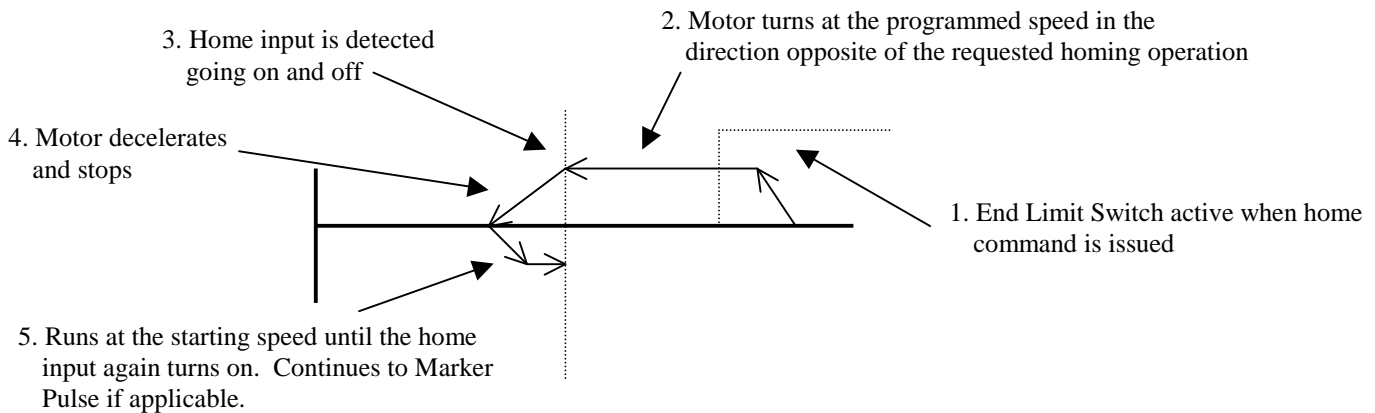

Note 1: The Home Input shown above can be either the Home Limit Switch or the Backplane Proximity bit.

Note 2: The above diagram is only true if the active End Limit Switch is the same as the issued home command, for example if the CW Limit Switch is active and a CW home command is issued. If the CW Limit Switch is active and a CCW home command is issued, than the unit will home normally, as if the end limit switch was not active.

Manual Move +/(CW), Manual Move -/(CCW)

This command performs the Manual Move operation at the programmed speed in the specified direction. Motion will occur as long as the command bit remains set. The Target Position register must be zero during all Manual Move operations. The state of the Encoder Move command bit is ignored when performing a Manual Move.

If the programmed speed is less than or equal to the starting speed, the starting speed is not used and the acceleration and deceleration parameters are ignored. The motor will “jump” to and run at the programmed speed without any acceleration. The speed cannot be changed when the module is running in this “constant speed mode.” If it is, a Command Error will be generated and the motion will be stopped.

If the programmed speed is greater than the starting speed, the axis begins the move at the starting speed, accelerates until the programmed speed is reached, and continues to move at the programmed speed until one of the following occurs:

- The Manual Move command bit is turned off
- The External Input, if configured, is activated
- The Immediate Stop output bit is set
- The Emergency Stop Input is activated
- The End Limit Switch in the same direction as the motion is reached
- The Programmed speed Changes

If the Manual Move command bit is turned off or if the External Input is active, the axis will decelerate at the programmed rate to the starting speed and stop, retaining a valid position. If the Immediate Stop Output bit or the Emergency Stop Input is used, the axis will stop without deceleration and the position will become invalid.

If the initial programmed speed is greater than the starting speed, the speed of a Manual Move operation can be changed without stopping the motion. If the velocity data is changed while the axis is moving, the module will accelerate or decelerate to the new speed, which can be less than the starting speed. The acceleration and or the deceleration parameters can also be changed, although these changes do not take affect until the programmed speed is changed. Both the acceleration and deceleration parameters must be valid when the speed is changed. If the changed velocity, acceleration, or deceleration parameters are invalid, motion will stop, command and invalid profile errors will be generated, and the position will become invalid.

An additional feature of the Manual Move parameter is the ability to do a One Shot Manual Move. With the programmed speed set to zero, a 0 → 1 transition of the Manual Move bit will cause the stepper controller to output 1 pulse in the specified direction. Please note that in One Shot Manual Move mode, the motion Direction bit will remain on and the Status LED will flash as long as the Manual Move command bit remains set. The Stopped status bit will not be set when the Manual Move command bit is reset.

If the End Limit Switch in the same direction as motion is reached during a Manual Move, the axis will stop without deceleration and the input error and position invalid input bits will be set. For example, reaching the CW Limit Switch during a CW Manual Move will stop the motion. However, an End Limit Switch in the direction opposite to motion will not stop a Manual Move operation. For example, reaching the CCW Limit Switch during a CW Manual Move. This feature allows the module to be moved off of an active end limit switch.

Preset Current Position and Diagnostic Feedback Position

This command will set the Current Position, and the Diagnostic Feedback value if appropriate, to the value present in the Target Position Registers. If the position is currently invalid, presetting the position will cause the position to become valid. The programmed speed, acceleration, and deceleration parameters must be zero when this command is sent to the module.

Preset Encoder Position

This command will set Current Encoder Value to the value present in the Target Position registers. The programmed speed, acceleration, and deceleration parameters must be zero when this command is sent to the module.

Reset Errors

This command clears all nonfatal errors detected by the stepper controller. A nonfatal error is one that can be recovered from. For example, requesting an Absolute Move when the position is not valid is a nonfatal error. When there is a Command Error, the controller will not perform any other operations until the Reset Errors command is issued.

General Command Mode Operation Notes

1. Only one command bit can be set at any one time.
2. A Command Error will be generated if a move operation is started before the previous move operation is completed. A move operation should only be started if the Move Complete, Stopped, or Hold status bits are set.
3. Only a 0 to 1 transition of any of the control bits listed above will cause the specified operation to take place.
4. If either the CW or CCW Limit Switches are reached during a normal move or manual move operation, the module will treat the input as an emergency stop, meaning that the motor will stop and the position will become invalid.
5. It is possible to home the 3202 module off of an end limit switch.

Blend Move

This command allows the user to create more complicated move profiles consisting of two to sixteen segments, as the following diagram illustrates.

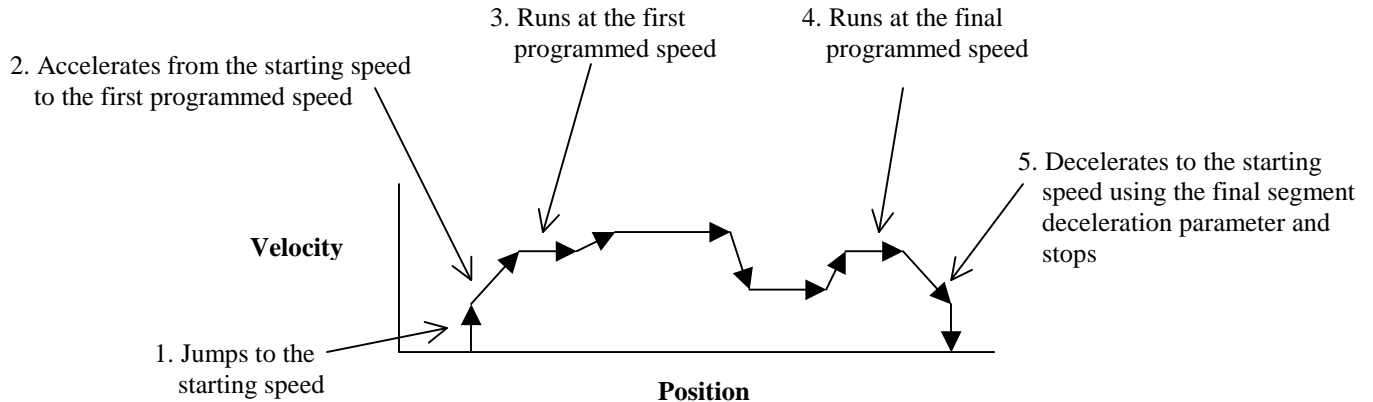

Each segment is defined by four parameters:

1. Acceleration Type (Constant, Triangular S Curve, or Trapezoidal S curve)
2. Relative Segment Length
3. Target speed
4. Acceleration/Deceleration Rate

The minimum amount of information necessary to define a new move segment is the Target Speed. The Segment Length and the Acceleration/Deceleration rate do not have to change from one segment to the next. An Invalid Profile Error will be generated if the Target Speed parameter is not different in two consecutive blend move segments.

The blend move programming is done at one time using a Message Instruction, with the segments of the blend move profile stored in the internal memory of the 3202. This data will remain in the module's memory until power is removed from the module, the configuration data is programmed, or a new blend move profile is sent to the unit.

The Blend Move Profile is programmed as a series of Relative Moves, so the position does not have to be valid for the blend move operation to take place. The first segment starts at the Starting Speed and accelerates to the specified Programmed speed. The starting speed for the next segment is equal to the programmed speed of the current segment. The final segment will decelerate from the final programmed speed to the starting speed and then stop. It is not possible to program a direction reversal in the blend move profile.

Because the 3202 stores the data for the Blend Move Profile in its memory, the programmed profile can be run more than once and from any location. Two command bits allow the blend move profile to be run in either direction. Please note that it is possible to perform other move or home operations between performing the blend move profiles.

Encoder Move

The 3202 has the ability to perform an Encoder Move, where the number of counts made by an incremental encoder determines the distance of the move. If bit 18 of the command word is set when an absolute or relative move is initiated, the 3202 module will begin a move profile using the programmed velocity and acceleration parameters. The programmed position is now the number of encoder counts to move. When this encoder count is reached, the 3202 module will begin to decelerate at the programmed deceleration rate, and stop. After motion has stopped, the 3202 module will set status bit 7, the Move Complete bit.

The following must be considered when using the Encoder Move function.

- The 3202 module uses X4 decoding on the encoder inputs, so the number of counts per turn of the encoder will be four times the encoder's resolution. For example, if a 1000 line encoder is being used, the 3202 will report 4000 counts per turn. This is the number that must be used when determining the position data of your encoder move.
- Absolute Encoder moves will be negative, motion in the Counter Clockwise direction, if the target position is less than the current encoder position.
- Relative Encoder moves will be negative, motion in the Counter Clockwise direction, only if the target position is negative.
- If the 3202 module is not configured to accept encoder inputs, attempting an encoder move will cause a command error to be generated.
- It is not possible to hold an encoder move. A backplane hold command issued during an encoder move will be ignored.
- Activating the External Input during an encoder move will cause the module to execute a controlled stop, but will not put the channel in a hold state.
- Setting bit 18 of the command word during a manual move or home operation will not have any affect on the 3202 module's profile.
- Before performing a Target Position absolute or relative move it will be necessary to reset bit 18 the command word.
- An Encoder Move will take place even if a working encoder is not attached to the module. If this occurs, motion will continue until it is stopped by an Emergency Stop Input, the External Input, or an Immediate Stop command.
- If the Encoder Move bit, bit 18, is reset while an Encoder Move is occurring, the move will not stop at the encoder count and the Emergency Stop Input or Immediate Stop command bit will have to be used to stop the move.

Diagnostic Feedback

By wiring the pulse and direction outputs to the encoder inputs, this feature can be used to verify program and module operation. When in diagnostic feedback mode, the module counts its own pulses and reports the position data in the Current Encoder/Diagnostic Feedback input register.

The maximum input frequency that the module can accurately measure in Diagnostic Feedback mode is 500kHz.

Acceleration Types

With the exception of homing operations, all of the move operations defined above allow the type of acceleration to be selected. The three options are described below.

Constant Acceleration: The module accelerates at a constant rate until the programmed speed is reached. This is the only option for homing operations.

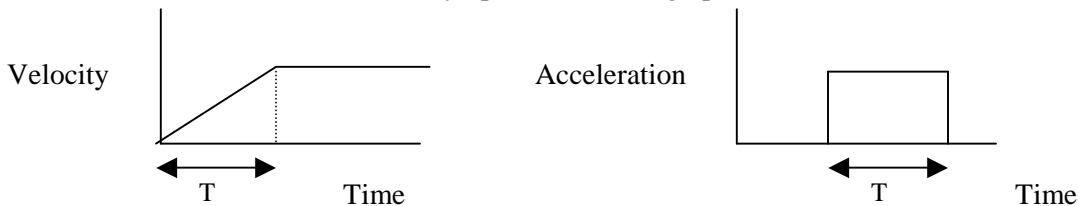

Triangular S Curve Acceleration: The module accelerates slowly at the beginning of the acceleration, faster at the middle of the acceleration, and again slowly at the end of the acceleration. The acceleration rate is never constant.

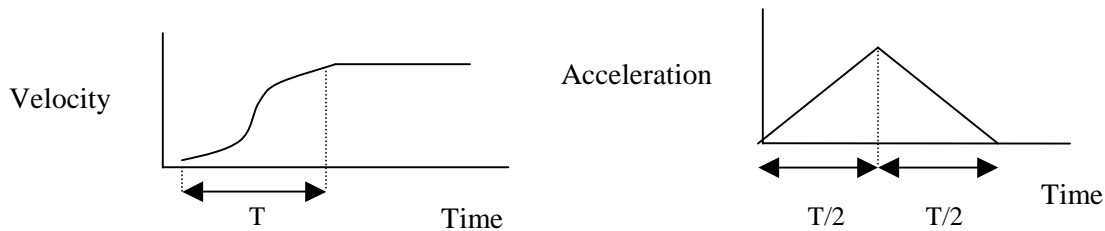

Trapezoidal S Curve Acceleration: The module accelerates slowly at the beginning of the acceleration, at a constant rate at the middle of the acceleration, and again slowly at the end of the acceleration.

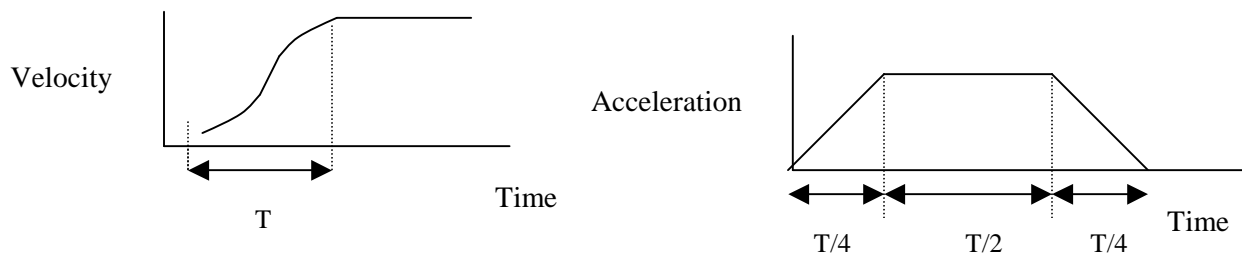

Notes:

1. The defined acceleration type is also applied to the deceleration.
2. Constant acceleration has the shortest acceleration time and Triangular S Curve has the longest acceleration time.
3. The constant portion of the Trapezoidal S Curve Acceleration is 50% of the total acceleration time.

Chapter 5: Command Mode Output Data

(Sixteen 32 bit words sent from the PLC to the 3202 module)

All stepper motor operations are performed in command mode. This mode is entered, after a successful configuration file has been transferred to the stepper controller, by resetting the Mode Flag bit 31. In Command Mode, the PLC program can issue commands and activate different operations or moves. A move profile typically consists of a Target Position, Programmed Speed, Acceleration, and Deceleration parameters. The following table shows the function of the output words.

32 bit Output Word	Channel	Function	Units	Range
0	1	Command Word		See description below
1	1	Target Position	Steps	-8,388,608 to 8,388,607
2	1	Programmed Speed	Steps/Second	Starting Speed to 1,000,000
3	1	Acceleration	Steps/Second/Second	1,000 to 2,000,000
4	1	Deceleration	Steps/Second/Second	1,000 to 2,000,000
5	1	Reserved		
6	1	Reserved		
7	1	Reserved		
8	2	Command Word		See description below
9	2	Target Position	Steps	-8,388,608 to 8,388,607
10	2	Programmed Speed	Steps/Second	Starting Speed to 1,000,000
11	2	Acceleration	Steps/Second/Second	1,000 to 2,000,000
12	2	Deceleration	Steps/Second/Second	1,000 to 2,000,000
13	2	Reserved		
14	2	Reserved		
15	2	Reserved		

Command Mode Programming Information

1. Only a single bit can be set at any one time in the Most Significant Command Word.
2. A Command Error will be generated if a move operation is started before the previous move operation has completed. A move operation should only be started if the Move Complete, Stopped, or Hold status bits are set.
3. A negative Target Position value will be programmed as a negative decimal number. If viewed in binary, this will be 2s compliment format.
4. The Position parameter has a range of $-8,388,608 \leq \text{Target Position} \leq 8,388,607$.
5. The Programmed Speed has a range of $\text{Starting Speed} \leq \text{Programmed Speed} \leq 1,000,000$ steps/sec.
6. The acceleration and deceleration parameters have a range of $1,000 \leq \text{acceleration / deceleration} \leq 2,000,000$ and is measured in steps/sec/sec.
7. Switching the PLC to Program Mode will cause any move operation to stop and the position to become invalid.

Command Word Layout

- bit 0 = set to start an ABSOLUTE MOVE operation
- bit 1 = set to start a RELATIVE MOVE operation
- bit 2 = set to perform a HOLD MOVE operation
- bit 3 = set to perform a RESUME MOVE operation
- bit 4 = set to perform an IMMEDIATE STOP operation
- bit 5 = set to start a FIND HOME +/(CW) operation
- bit 6 = set to start a FIND HOME -/(CCW) operation
- bit 7 = set to start a MANUAL MOVE +/(CW) operation. Reset this bit to stop the Manual Move Operation.
- bit 8 = set to start a MANUAL MOVE -/(CCW) operation. Reset this bit to stop the Manual Move Operation.
- bit 9 = set to PRESET the Current Position and if appropriate the Diagnostic Feedback data. This bit does not reset the Move Complete input bit.
- bit 10 = set to PRESET optical encoder
- bit 11 = set to perform a RESET ERRORS operation on this channel. (Errors on the other channel will be unaffected)
- bit 12 = set to RUN BLEND MOVE PROFILE in the positive direction
- bit 13 = set to RUN BLEND MOVE PROFILE in the negative direction
- bits 14 & 15 = reserved
- bit 16 = reset for CONSTANT ACCELERATION, set for S CURVE ACCELERATION
- bit 17 = reset for TRIANGULAR S CURVE ACCELERATION, set for TRAPEZOIDAL S CURVE ACCELERATION. This bit is ignored if bit 16 is not set.
- bit 18 = reset for a TARGET POSITION move, set for an ENCODER COUNT move
- bits 19 to 28 = Reserved
- bit 29: Backplane Home Proximity bit.
 - The backplane proximity bit is set by the PLC to indicate to the 3202 module that you are nearing the location of the Home Limit Switch.
 - The 3202 module will ignore the state of this bit unless the module was configured to accept backplane home proximity operations, and if there is no homing operation taking place
- bit 30 = reserved
- bit 31 = MODE FLAG: "1" for Configuration Mode "0" for Command Mode

Blend Move Programming

A Blend Move consists of up to sixteen segments consisting of a Relative Segment Length, a Target Velocity, the Acceleration and Deceleration parameters. The entire Blend Move profile is made up of 52 32 bit words, 208 bytes, and is programmed all at one time using a Message Instruction. The blend move operation will be run each time bit 12 or 13 in the output Command word transitions from 0 to 1.

The following is an example of the Message Instruction

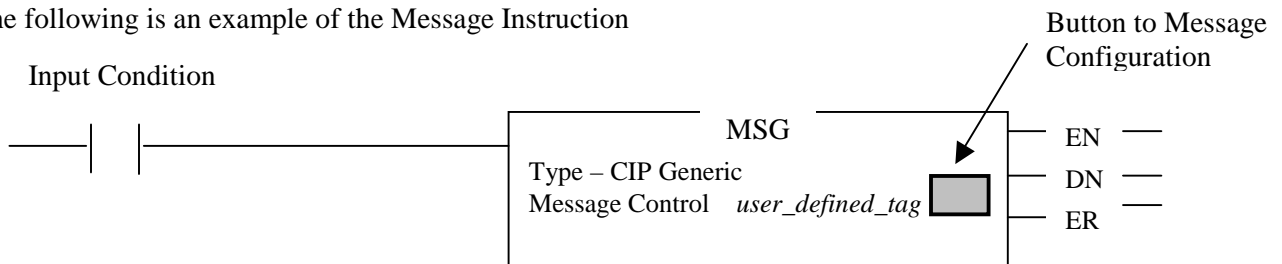

1. Programming the configuration data clears the stored blend profile data.
2. The message instruction sends data to the 3202 module only when the rung transitions from false to true.
3. The *user_defined_tag* used for Message Instruction Control must have the MESSAGE data type.
4. Clicking on the button in the Message Instruction opens the Message Configuration Window, shown below.

Message Configuration – *user defined tag* (Configuration Tab)

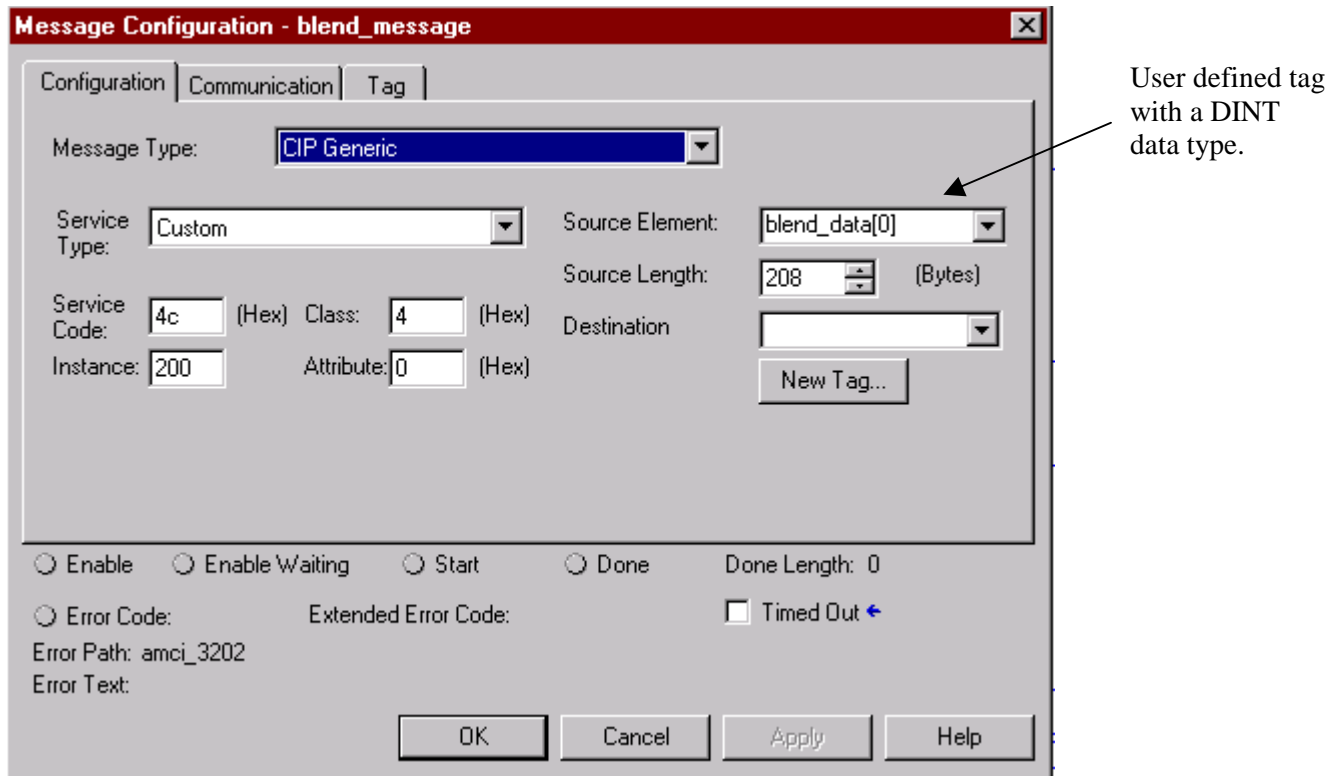

Note: The Source Element is a user defined tag at least 208 bytes in length with a DINT data type. All of the other Message Instruction parameters should be programmed as shown above.

Message Configuration – user defined tag (Communication Tab)

When the Configuration window shown above is completed, click on the Communication tab and set the path parameter to the 3202 module. All of the remaining Communication parameters can remain at their default settings.

The following table shows the layout of the Blend Move data sent with the Message Instruction.

BLEND MOVE DATA

Word	Segment	Function
0	ALL	Channel Number
1	N/A	Number of Segments
2	ALL	Acceleration Type
3	N/A	Final Deceleration & Deceleration Type
4	1	Segment Length
5	1	Target Speed
6	1	Acceleration/Deceleration
7	2	Segment Length
8	2	Target Speed
9	2	Acceleration/Deceleration
10	3	Segment Length
11	3	Target Speed
12	3	Acceleration/Deceleration
13	4	Segment Length
14	4	Target Speed
15	4	Acceleration/Deceleration
16	5	Segment Length
17	5	Target Speed
18	5	Acceleration/Deceleration
19	6	Segment Length
20	6	Target Speed
21	6	Acceleration/Deceleration
22	7	Segment Length
23	7	Target Speed
24	7	Acceleration/Deceleration

Word	Segment	Function
25	8	Segment Length
26	8	Target Speed
27	8	Acceleration/Deceleration
28	9	Segment Length
29	9	Target Speed
30	9	Acceleration/Deceleration
31	10	Segment Length
32	10	Target Speed
33	10	Acceleration/Deceleration
34	11	Segment Length
35	11	Target Speed
36	11	Acceleration/Deceleration
37	12	Segment Length
38	12	Target Speed
39	12	Acceleration/Deceleration
40	13	Segment Length
41	13	Target Speed
42	13	Acceleration/Deceleration
43	14	Segment Length
44	14	Target Speed
45	14	Acceleration/Deceleration
46	15	Segment Length
47	15	Target Speed
48	15	Acceleration/Deceleration
49	16	Segment Length
50	16	Target Speed
51	16	Acceleration/Deceleration

Word 0: Channel Number

This parameter has a range of 1 or 2 and defines which of the two channels the blend move data is assigned to. A value other than 1 or 2 will generate an Invalid Profile error.

Word 1 Number of Segments

This parameter defines the number of blend move segments that are being programmed. This parameter has a range of 2 to 16. A value outside of this range will generate an Invalid Profile Error. Any data contained in the segments beyond the number defined by this parameter will be ignored.

Word 2 Acceleration Type

Every two bits in this word define the acceleration type of each segment. When the least significant bit of the two is reset, the acceleration type of the segment will be Constant. When the least significant bit of the two is set, the state of the most significant bit determines the type of S curve acceleration. If the most significant bit is reset, triangular S curve acceleration will be used. If the most significant bit is set, trapezoidal S curve acceleration will be used. The following table shows an example of how the bits in this word are used.

Segment	MSB of pair	LSB of pair	Function
1 Bits 1 & 0	0	0	Constant Acceleration
	0	1	Triangular S Curve Acceleration
	1	1	Trapezoidal S Curve Acceleration
2 Bits 3 & 2	0	0	Constant Acceleration
	0	1	Triangular S Curve Acceleration
	1	1	Trapezoidal S Curve Acceleration

15 Bits 29 & 28	0	0	Constant Acceleration
	0	1	Triangular S Curve Acceleration
	1	1	Trapezoidal S Curve Acceleration
16 Bits 31 & 30	0	0	Constant Acceleration
	0	1	Triangular S Curve Acceleration
	1	1	Trapezoidal S Curve Acceleration

Word 3: Final Segment Deceleration Value & Deceleration Type Bits

This word defines both the deceleration rate and type between the final segments programmed speed and the starting speed. The two Most Significant bits in this 32 bit are used to define the deceleration type.

Bit 31	Bit 30	Function
0	0	Constant Acceleration
0	1	Triangular S Curve Acceleration
1	1	Trapezoidal S Curve Acceleration

Segment Length

- The sum of all of the segment lengths cannot exceed 8,388,607.
- The segment lengths must be positive.

Acceleration/Deceleration Parameters

This parameter defines the rate of change of the speed between two adjacent segments. If the speed in the next segment is greater than the speed in the current segment, then this parameter will be used as an acceleration value. If the speed in the next segment is less than the speed in the current segment, then this parameter will be used as a deceleration value.

Chapter 6: Command Mode Input Data

(Sixteen 32 bit words sent from the 3202 module to the PLC)

Sample Programs showing how to program the 3202 module are available from the following page of our website; <http://www.amci.com/sampleprograms.asp>

32 bit Input Word	Channel	Command Mode Input Data	Units
0	1	Status Word	See Description Below
1	1	Current Position	Counts (# of steps output)
2	1	Current Encoder / Diagnostic Feedback Data	Encoder Counts using X4 decoding
3	1	Captured Data	Counts
4	1	0	0
5	1	0	0
6	1	0	0
7	1	0	0
8	2	Status Word	See Description Below
9	2	Current Position	Counts (# of steps output)
10	2	Current Encoder / Diagnostic Feedback Data	Encoder Counts using X4 decoding
11	2	Captured Data	Counts
12	2	0	0
13	2	0	0
14	2	0	0
15	2	0	0

Status Word Layout

- bit 0 = set when the axis is moving CW
- bit 1 = set when the axis is moving CCW
- bit 2 = set when the stepper controller is in a HOLD STATE
- bit 3 = set when the axis is STOPPED (This bit will not be set if the Move Complete, At Home, or Hold bits are set)
- bit 4 = set when the axis is AT HOME at the completion of a homing operation
- bit 5 = set when the axis is ACCELERATING
- bit 6 = set when the axis is DECELERATING
- bit 7 = set when MOVE COMPLETE. Valid for Absolute, Relative, and Blend Moves
- bit 8 = set when the stepper controller is running a BLEND MOVE profile
- bit 9 = reserved
- bit 10 = set when POSITION INVALID
- bit 11 = set when there is an INPUT ERROR (A move can be initiated when there is an Input Error)
- bit 12 = set when there is a COMMAND ERROR, must be reset before another command, including an Immediate Stop, will be accepted
- bit 13 = set when there is a CONFIGURATION ERROR (This bit is not set when the channel is disabled)
- bit 14 = set when there is a HOME INVALID ERROR
- bit 15 = set when there is an INVALID PROFILE

Status Word Layout (Continued)

bit 16 = set when the CAPTURE INPUT is active
bit 17 = set when the EXTERNAL INPUT is active
bit 18 = set when the HOME LIMIT SWITCH input is active
bit 19 = set when the EMERGENCY STOP input is active
bit 20 = set when the CW LIMIT SWITCH input is active
bit 21 = set when the CCW LIMIT SWITCH input is active
bits 22 to 27: Reserved
bit 28 = channel disabled (set when the channel has not been configured after power up)
bit 29 = set when the backplane home proximity output bit is set, even if no home operation is occurring.
bit 30 = MODULE OK bit, set when the module is working correctly
bit 31 = MODE FLAG "1" configuration mode, "0" for command mode

CURRENT POSITION

This word reports the Current Position based on the number of pulses that have been output to the stepper driver. This value may be different from the Encoder Position. A negative Current Position value will be displayed as a negative decimal number. If viewed in binary, this will be 2s compliment format. When switching from Configuration Mode to Command Mode, the Current Position will be reset to zero.

The current position data is not limited by the $\pm 8,388,607$ range of the output parameters. It instead uses all 32 bits in the data word and has a range of 0 to ffff_ffffh. Please note that because the Most Significant Bit is used to indicate the sign, the value will become negative when it changes from 7ff_ffffh to 1000_0000h.

ENCODER POSITION

This word reports the position based on the feedback from an encoder attached to the stepper motor. This value may be different from the Current Position. A negative Encoder Position value will be displayed as a negative decimal number. If viewed in binary, this will be 2s compliment format.

As with the current position data, the Encoder Position uses all 32 bits in the data word and has a range of 0 to ffff_ffffh.

CAPTURED DATA

This word reports the data captured when the Capture Input transitions from inactive to active. The value captured will depend on how the 3202 module is configured. If the module's configuration did not include the Quadrature Encoder, the Current Position Data will be captured. If the module's configuration did include the Quadrature Encoder, the Encoder Data will be captured.

Only modules with firmware versions 3.1 or later can capture the Current Position data. Firmware versions 2.2 or lower can only capture the encoder data.

Negative Captured Data value will be displayed as a negative decimal number. If viewed in binary, this will be 2s compliment format. As with the current and encoder position data, the Captured Encoder Position uses all 32 bits in the data word and has a range of 0 to ffff_ffffh.

The Captured Data value cannot be reset from the PLC and will be cleared by a homing operation.

The Stopped Bit will be set under the following conditions

1. When a CW or CCW Manual Move operation has been completed.
2. When the Emergency Stop input has been used to stop a move operation.
3. When the Immediate Stop command bit has been used to stop a move operation
4. When either the CW or CCW Limit switches have been reached during any move operation except Homing.

The Stopped bit will not be set after an Absolute or Relative Move, after a Homing Operation, after a Blend Move, or when a move operation is in a Hold State.

The Move Complete Bit will be set under the following conditions

After an Absolute Move, a Relative Move, or a Blend Move have been successively completed. The Move Complete bit will be reset when the next move operation is initiated.

The Position Invalid will be set under the following conditions

1. After a configuration operation has occurred. This will be true even if the position was valid before the configuration operation occurred.
2. After an Immediate Stop command has been issued.
3. If the Emergency Stop input has been activated.
4. If either of the End Limit Switches become active during any move operation except for homing and if the same end limit is reached during a Manual Move. For example, if the CW Limit Switch is reached during a CW Manual Move.
5. If both End Limit Switches are reached during a homing operation. This error will only occur when the motor has reversed direction after encountering the first End Limit switch.
6. If the opposite End Limit Switch is reached during a homing operation. For example, if the CCW Limit Switch is first reached during a CW homing operation. Improper wiring or placement of the limit switch would most likely cause this error.

The Input Error bit will be set under the following conditions

1. If the Emergency Stop input has been activated
2. If either of the End Limit Switches become active during any move operation except for homing and if the same end limit is reached during a Manual Move. For example, if the CW Limit Switch is reached during a CW Manual Move.
3. Starting a manual move in the same direction as an active end limit switch.
4. If both End Limit Switches are reached during a homing operation. This error will only occur when the motor has reversed direction after encountering the first End Limit switch.
5. If the opposite End Limit Switch is reached during a homing operation. For example, if the CCW Limit Switch is first reached during a CW homing operation. Improper wiring or placement of the limit switch would most likely cause this error.

A Command Error will be generated under the following conditions

1. Configuring the unit while a move operation is occurring. The move will run to completion and then the Configuration will be allowed to occur, clearing the command error.
2. If more than one Command bit is set. The exceptions are bits 16 and 17, the acceleration type bits, and bit 18, the encoder move bit. Bit 29, the backplane home proximity bit, can be set at any time.
3. If the Target Position, Programmed Speed, Acceleration, or Deceleration parameters are outside of their valid ranges.
4. If the programmed speed is less than the starting speed. This applies to Absolute Moves, Relative Moves, Homing operations, and Blend Moves. However, Manual Moves can be run at speeds less than the starting speed.
5. If any of the reserved output registers are not set to zero.
6. Performing an Absolute Move when the Current Position is not valid.
7. Issuing a Hold Command when there is no Absolute or Relative move in progress. For example, during Manual Moves, Blend Moves, or Home operations.
8. Issuing a Resume command when the channel is not in a Hold state.
9. A Preset Command, including Encoder Preset, that has data in the registers that contain the Programmed Speed, Acceleration, or Deceleration parameters.
10. Issuing a Homing Command with S-Curve Acceleration selected.
11. Attempting to Preset the Encoder position when the module has not been configured to use an encoder.

Command Errors generated by Manual Move Operations

12. Performing a Manual Move with data in the Target Position registers.
13. Placing a non zero value in the Target Position registers for a Manual Move that is occurring.
14. If the speed of a Manual Move is changed to zero.
15. Changing the speed of a Manual Move whose initial speed was less than or equal to the starting speed.
16. If invalid changes are made to the velocity, acceleration, or deceleration parameters of a Manual Move that is occurring. Note that changes to the Acceleration and Deceleration parameters are only taken into account when the 3202 module detects a change in the Velocity parameter.

Command Errors generated by Blend Move Operations

17. If a Blend Move operation was initiated before the profile was programmed using a message instruction.
18. If a blend move profile is started with data in the target position, programmed speed, acceleration, or deceleration parameters.
19. If a blend move profile is programmed while a blend move operation is in progress. If this occurs, the final segments deceleration will be used to immediately stop the motion.
20. If the hold command is issued while a blend move profile is running. If this occurs, the command error bit will be set while the blend move profile runs to completion, when the Command Error bit will be reset.

The Configuration Error bit will be set under the following conditions

1. If an invalid configuration has been sent to the module.

The Home Invalid bit will be set under the following conditions

1. Issuing a Homing command with the Target Position registers not equal to zero.
2. Issuing a Home command if the Programmed Speed is less than the starting speed.
3. Issuing a Home command in a direction that does not have an End Limit Switch configured.
4. Issuing a Home command with the reserved words not equal to zero.
5. If both End Limit Switches are reached during a homing operation. This error will only occur when the motor has reversed direction after encountering the first End Limit switch.
6. If the opposite End Limit Switch is reached during a homing operation. For example, if the CCW Limit Switch is first reached during a CW homing operation. Improper wiring or placement of the limit switch would most likely cause this error.

The Invalid Profile bit will be set under the following conditions

1. If the Programmed Speed is less than the starting speed.
2. If any of the move parameters are outside of their valid ranges.
3. If any of the reserved output registers are not set to zero.
4. If the defined profile overflows the internal registers of the 3202 module.
5. Changing the speed of a Manual Move whose initial speed was less than or equal to the starting speed.
6. Changing the Manual Move Speed to zero.
7. Starting a Manual Move with the Target Position not equal to zero.
8. Placing a non zero value in the Target Position registers for a Manual Move that is occurring.
9. If invalid changes are made to the velocity, acceleration, or deceleration parameters of a Manual Move that is occurring. Note that changes to the Acceleration and Deceleration parameters are only taken into account when the 3202 module detects a change in the Velocity parameter.
10. Initiating an Encoder Move when the module has not been configured to use an encoder.
11. If the blend move channel number is not equal to 1 or 2.
12. Setting the number of Blend Move Segments to be less than 2 or greater than 16.
13. If a Blend Move segment does not reach the Programmed Speed. That is, if the distance that it takes to accelerate to the programmed speed exceeds the length of the segment.
14. Programming a Blend Move segment with no change in the Programmed Speed from the previous segment.
15. Programming a Blend Move Profile before configuring the module.
16. If the sum of the Blend Move Segment Lengths exceeds 8,388,607.

The Module OK Flag

This bit will be set as long as the module is operating. This bit may briefly be reset when the module changes from Configuration Mode to Command Mode.

Revision History

Revision 0.0 was released on 2/6/02 and was the initial version of the specifications.

Revision 0.1 was released on 6/14/02. The following changes were made to the specifications.

1. The ability to disable an unused channel at power up was added.
2. A channel disabled status bit was added (status word, bit 28).
3. The backplane home proximity bit was moved from bit 30 to bit 29. Input Status bit 29 now indicates when the home proximity output bit set.
4. The function of the LEDs was changed. A solid red status LED now indicates when the module failed power up diagnostics. A solid red OK LED now indicates a module fault.
5. The requirement of an external 24Vdc power supply has been removed. The unit now has an internal isolated power supply to drive the pulse and direction output signals. Connector pins 35 and 36 are now External Common.

Revision 1.0 was released on 9/18/02. The following changes were made to the specification.

1. Blend Move operations were changed from being absolute to relative moves.
2. The ability to perform blend moves in either direction was added. There are now two command bits that initiate a blend move, bit 12 performs a blend move in the positive direction and bit 13 performs a blend move in the negative direction.
3. The acceleration type bits were moved from bits 13 and 14 to bits 16 and 17.
4. The type of move, target position or encoder move, was moved from bit 15 to bit 18.
5. The reserved input was changed to the capture input. The encoder capture function was moved from the external input to the capture input.
6. The rack configuration data was added to the specifications.
7. The M3202 rev – board had incorrect encoder wiring and the wiring information was changed to reflect this.
8. An example program was added.
9. The Preset Position Command text was changed because it also affects the Diagnostic Feedback data. The Preset Encoder command does not affect the diagnostic feedback data.
10. The Captured Encoder value will now be cleared by a home operation.
11. The Backplane Home Proximity configuration bit was moved from bit 13 to bit 6.

Revision 1.2 was released on 10/1/02. The following changes were made to the specification

1. A note on how the acceleration type must be selected when resuming a move was added.
2. A note on how changing the speed of a manual move that was started less than or equal to the starting speed was added.
3. Acceleration vs. time plots were added to the acceleration type information.
4. S Curve Acceleration is not allowed during homing operations.

Revision 1.3 was released on 10/4/02. The following change was made.

1. The example program was incorrect. The current position data is in Local:3:I.data[1] not Local:3:I.data[0].

Revision 2.0 was released on 10/22/01. The following changes were made.

1. The 3202 is now a Rev A module.
2. The module's connector pin layout was changed. The location of the encoder inputs has been changed and the unit no longer requires an external power supply.
3. Errors in the Blend Move programming word layout were corrected.
4. Diagrams showing how to wire single ended encoders that operate at different voltage levels were added.
5. The power supply requirements were changed.

Revision 3.0 was released on 2/26/03. The following changes were made.

1. The minimum RPI time was changed from 0.3ms to 0.5ms. A recommended RPI time of 3ms was also added. This change was made because there is a chance of a momentary loss of communication between the module and the PLC at the faster times.
2. A wiring diagram showing how to connect the step and directions signals to a driver with differential inputs was added to the specifications.
3. The cause of the various error bits was updated. There was no change to the functionality, just to the documentation.
4. Information was added on the maximum input frequency of the encoder inputs.
5. A note was added on how the module will be displayed in RSNetworkx.
6. Information on what will cause the configuration error and position invalid bit to be set was added.
7. The ability to capture either the encoder data or the current position data was added to the module.

Revision 3.1 was released on 8/13/03. The following changes were made.

1. The Assembly Instance and Input Size for Listen Only operations was added.
2. Details on the Stopped Bit were added.
3. Details on the Move Complete bit were added.
4. Added details that a Home Invalid and Invalid Profile error will cause the Status LED to flash red.

Revision 3.2 was released on 12/11/03. The following changes were made.

1. A note was added that RPI times below 3ms might occasionally cause the 3202 module to temporarily stop communicating with the PLC.
2. The stepper output specifications were changed from 5V to 5V differential. A note was also added that the typical voltage level of the outputs will be 3.5 to 4Vdc.

Revision 4.0 was released on 7/3/06. The following changes were made.

1. General Information was added
2. Table of Contents was added
3. Module Specifications, wiring information, and front panel description was moved to the front of the specifications.
4. A diagram of output signals types was added.
5. A chapter on calculating move profiles was added.
6. The recommended RPI time was changed from 3ms to 5ms.
7. The sample programs were removed from the specifications and replaced with links to the online versions of the sample programs.