

# **DC25**

## **Analog Output**

### **DuraCoder**

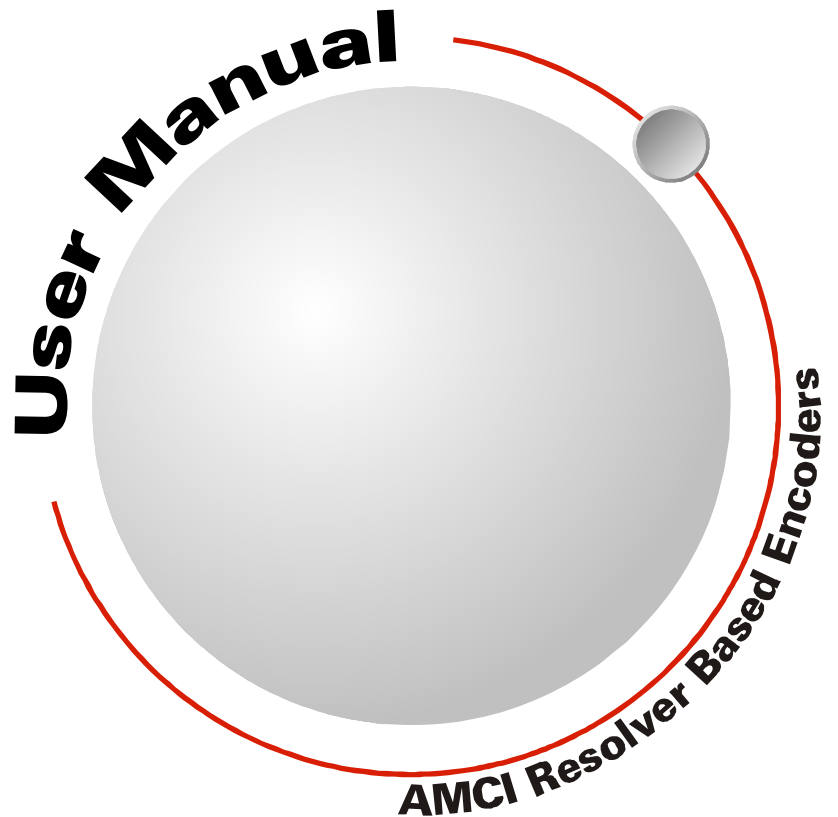

# GENERAL INFORMATION

## **Important User Information**

The products and application data described in this manual are useful in a wide variety of different applications. Therefore, the user and others responsible for applying these products described herein are responsible for determining the acceptability for each application. While efforts have been made to provide accurate information within this manual, AMCI assumes no responsibility for the application or the completeness of the information contained herein.

UNDER NO CIRCUMSTANCES WILL ADVANCED MICRO CONTROLS, INC. BE RESPONSIBLE OR LIABLE FOR ANY DAMAGES OR LOSSES, INCLUDING INDIRECT OR CONSEQUENTIAL DAMAGES OR LOSSES, ARISING FROM THE USE OF ANY INFORMATION CONTAINED WITHIN THIS MANUAL, OR THE USE OF ANY PRODUCTS OR SERVICES REFERENCED HEREIN.

No patent liability is assumed by AMCI, with respect to use of information, circuits, equipment, or software described in this manual.

The information contained within this manual is subject to change without notice.

This manual is copyright 2016 by Advanced Micro Controls Inc. You may reproduce this manual, in whole or in part, for your personal use, provided that this copyright notice is included. You may distribute copies of this complete manual in electronic format provided that they are unaltered from the version posted by Advanced Micro Controls Inc. on our official website: [www.amci.com](http://www.amci.com). You may incorporate portions of this documents in other literature for your own personal use provided that you include the notice "Portions of this document copyright 2016 by Advanced Micro Controls Inc." You may not alter the contents of this document or charge a fee for reproducing or distributing it.

## **Standard Warranty**

ADVANCED MICRO CONTROLS, INC. warrants that all equipment manufactured by it will be free from defects, under normal use, in materials and workmanship for a period of [18] months. Within this warranty period, AMCI shall, at its option, repair or replace, free of charge, any equipment covered by this warranty which is returned, shipping charges prepaid, within eighteen months from date of invoice, and which upon examination proves to be defective in material or workmanship and not caused by accident, misuse, neglect, alteration, improper installation or improper testing.

The provisions of the "STANDARD WARRANTY" are the sole obligations of AMCI and excludes all other warranties expressed or implied. In no event shall AMCI be liable for incidental or consequential damages or for delay in performance of this warranty.

## **Returns Policy**

All equipment being returned to AMCI for repair or replacement, regardless of warranty status, must have a Return Merchandise Authorization number issued by AMCI. Call (860) 585-1254 with the model number and serial number (if applicable) along with a description of the problem during regular business hours, Monday through Friday, 8AM - 5PM Eastern. An "RMA" number will be issued. Equipment must be shipped to AMCI with transportation charges prepaid. Title and risk of loss or damage remains with the customer until shipment is received by AMCI.

## **24 Hour Technical Support Number**

24 Hour technical support is available on this product. If you have internet access, start at [www.amci.com](http://www.amci.com). Product documentation and FAQ's are available on the site that answer most common questions.

If you require additional technical support, call (860) 583-1254. Your call will be answered by the factory during regular business hours, Monday through Friday, 8AM - 5PM Eastern. During non-business hours an automated system will ask you to enter the telephone number you can be reached at. Please remember to include your area code. The system will page an engineer on call. Please have your product model number and a description of the problem ready before you call.

## **We Want Your Feedback**

Manuals at AMCI are constantly evolving entities. Your questions and comments on this manual are both welcomed and necessary if this manual is to be improved. Please direct all comments to: Technical Documentation, AMCI, 20 Gear Drive, Terryville CT 06786, or fax us at (860) 584-1973. You can also e-mail your questions and comments to [techsupport@amci.com](mailto:techsupport@amci.com)

# TABLE OF CONTENTS

## **General Information**

Important User Information .....	2
Standard Warranty .....	2
Returns Policy .....	2
24 Hour Technical Support Number .....	2
We Want Your Feedback .....	2

## **About this Manual**

Audience .....	3
Applicable Units .....	3
Navigating this Manual .....	3
Manual Conventions .....	3
Trademarks and Other Legal Stuff .....	3
Revision Record .....	4
Manual Layout .....	4

## **Reference: DC25 Specifications**

Overview .....	5
Part Number Description .....	5
Electrical Specifications .....	6
Mechanical Specifications .....	6
Environmental Specifications .....	6
Output Waveforms .....	7
Output Period .....	7
Voltage Output Waveforms .....	7
Current Output Waveforms .....	7
Output Load Calculations .....	8
Voltage Output DuraCoder .....	8
Current Output DuraCoder .....	8
Connector Pinouts .....	8
MS Connector -	
Aluminum Body .....	8
M12 Connector -	
Stainless Steel Body .....	9
Mating Connector and Cordsets .....	10
MS Connector -	
Aluminum Body .....	10
M12 Connector -	
Stainless Steel Body .....	11
Integral Cable Option .....	11
Cable Colors .....	11

## **Task: Physical Installation**

Installation Guidelines .....	13
Electrostatic Discharge	
Prevention .....	13
Suitable Environment .....	13
Shaft Loading .....	13
A Note on Cable Direction .....	13
Outline Drawings .....	14
Flange Mount, Aluminum Body,	
End Connect .....	14
Flange Mount, Aluminum Body,	
Side Connect .....	14
Flange Mount, Stainless Steel	
Body, Side Connect .....	15
Shaft Details -	
Flange Mount Option .....	15
Servo Mount, Aluminum Body,	
End Connect .....	16
Servo Mount, Aluminum Body,	
Side Connect .....	16
Servo Mount, Stainless Steel	
Body, Side Connect .....	17
Shaft Details -	
Servo Mount Option .....	17
Hub Shaft Mount, Aluminum	
Body, End Connect .....	18
Hub Shaft Mount, Aluminum	
Body, Side Connect .....	19
Hub Shaft Mount, Stainless Steel	
Body, Side Connect .....	20
5/8" Shaft, Face Mount,	
Aluminum Body, End Connect ..	21
5/8" Shaft, Face Mount,	
Aluminum Body, Side Connect ..	22
5/8" Shaft, Face Mount, Stainless	
Steel Body, Side Connect .....	23
Integral Cable Option .....	24

**Task: Wire Power and I/O**

Wiring Guidelines .....	25
Aluminum DC25 with MS Connector .....	25
MS Connector Pinout .....	25
Right Angle Cable	
Exit Direction .....	26
AMCI Mating Connector	
and Cable .....	26
Sample Wiring Diagram .....	27
Stainless Steel DC25 with	
M12 Connector .....	28
M12 Connector Pinout .....	28
Right Angle Cable	
Exit Direction .....	29
AMCI Mating Connector and	
Cordset .....	29
Sample Wiring Diagram .....	30
Integral Cable (FL option) .....	31
Cable Pinout .....	31
Sample Wiring Diagram .....	32

# ABOUT THIS MANUAL

Read this chapter to learn how to navigate through this manual and familiarize yourself with the conventions used in it. The last section of this chapter highlights the manual's remaining chapters and their target audience.

## Audience

This manual explains the installation and operation of AMCI's DC25 series of resolver based encoders with analog outputs. It is written for the engineer responsible for incorporating the DC25 into a design as well as the engineer or technician responsible for its actual installation.

## Applicable Units

This manual is applicable to all DC25 encoders with analog outputs. All of these units offer 12 bit position resolution per turn. Outputs include multiple voltage and current options. If you need a higher position resolution, or an analog output that spans multiple turns, consider using the AMCI DC60 line of analog encoders, which offers up to 16 bit position resolution.

## Navigating this Manual

This manual is designed to be used in both printed and on-line forms. Its on-line form is a PDF document, which requires Adobe Acrobat Reader version 7.0+ to open it. You are allowed to select and copy sections for use in other documents. If you own Adobe Acrobat Reader version X+ or Adobe Acrobat version 7.0+, you are allowed to add notes and annotations. If you decide to print out this manual, all sections contain an even number of pages which allows you to easily print out a single chapter on a duplex (two-sided) printer.

## Manual Conventions

Three icons are used to highlight important information in the manual:



**NOTES** highlight important concepts, decisions you must make, or the implications of those decisions.



**CAUTIONS** tell you when equipment may be damaged if the procedure is not followed properly.



**WARNINGS** tell you when people may be hurt or equipment may be damaged if the procedure is not followed properly.

The following table shows the text formatting conventions:

Format	Description
Normal Font	Font used throughout this manual.
<i>Emphasis Font</i>	Font used for parameter names and the first time a new term is introduced.
<i>Cross Reference</i>	When viewing the PDF version of the manual, clicking on a blue cross reference jumps you to referenced section of the manual.
<i>HTML Reference</i>	When viewing the PDF version of the manual, clicking on a red cross reference opens your default web browser to the referenced section of the AMCI website if you have Internet access.

## Trademarks and Other Legal Stuff

The AMCI logo is a trademark of Advanced Micro Controls Inc. "DuraCoder" is a registered trademark of Advanced Micro Controls Inc. "Adobe" and "Acrobat" are registered trademarks of Adobe Systems Incorporated.

All other trademarks contained herein are the property of their respective holders.

**Revision Record**

This manual, 940-0D025 is the fifth release of this manual. It changes the format of the manual, adds information on the stainless steel versions of the DC25 encoders, and adds information on the integral cable option. It was first released on December 5<sup>th</sup>, 2016.

**Manual Layout**

You will most likely read this manual for one of two reasons:

- If you are curious about the DC25 analog encoder, this manual contains the information you need to determine if the DC25 is the right product for your application. Chapter 1, DC25 Specifications, was written for you. The chapter contains all of the information you will need to fully specify the DC25 product in your application.
- If you need to install and use the DC25, then the rest of the manual is written for you. To simplify installation and configuration, the rest of the manual is broken down into *tasks*. Using the DC25 requires you to complete two tasks, and the manual is broken down into sections that explain how to complete each one.

<b>Chapter Title</b>	<b>Chapter Description</b>	<b>Starting Page</b>
<i>DC25 Specifications</i>	Complete specifications of the DC25 analog output products.	5
<i>Physical Installation</i>	Task instructions that give you the information and steps needed to physically install a DC25 analog encoder on your machine.	13
<i>Wire Power and I/O</i>	Task instructions that give you the information and steps needed to wire power and I/O connections to the analog DC25. These instructions are applicable to both bench top and machine wiring.	25

# DC25 SPECIFICATIONS

## Overview

The analog DC25's are members of a line of heavy-duty resolver based encoder products from AMCI. The resolver's signals are decoded into a 12 bit position value by electronics incorporated into the DuraCoder. This 12 bit (4096 count), absolute position value is then converted to an analog output. Several different voltage and current outputs are available, as well as the amount of shaft rotation needed to generate the full scale output.

The bodies of the Analog DuraCoders are available in powder coated aluminum or 316 stainless steel and in a variety of industry standard size 25 optical encoder packages. A flange mount unit with its connector on the end is shown in figure 1. The following mounting styles are available:

- 2.5 inch flange mount
- 2.5 inch servo mount
- 63 mm blind shaft mount
- 2.65 inch face mount (AMCI standard) with 0.625" shaft for applications with high shaft loads.

A variety of inch and metric shaft sizes are available for the 2.5 inch and 63mm packages.

Your Analog DuraCoder can be ordered with a current or voltage output. The available current outputs are 4 to 20 mA or 0 to 20 mA. The available voltage outputs are 0 to +5 Vdc, 0 to +10 Vdc, or -10 to +10 Vdc.

Aluminum bodied units offer a military spec. MS3102E18-1P connector for power and I/O connections. Stainless steel units offer an industry standard M12, 8 pin, A-coded, male connector for power and I/O connections. Both end (axial) and side (radial) connector placement options are available with the aluminum body. Side (radial) connector placement is the only option with the stainless steel body. Outline drawings of the packaging options are available in the [Outline Drawings](#) section of the manual starting on page 14.



Figure 1 DC25 Resolver Based Encoder

## Part Number Description

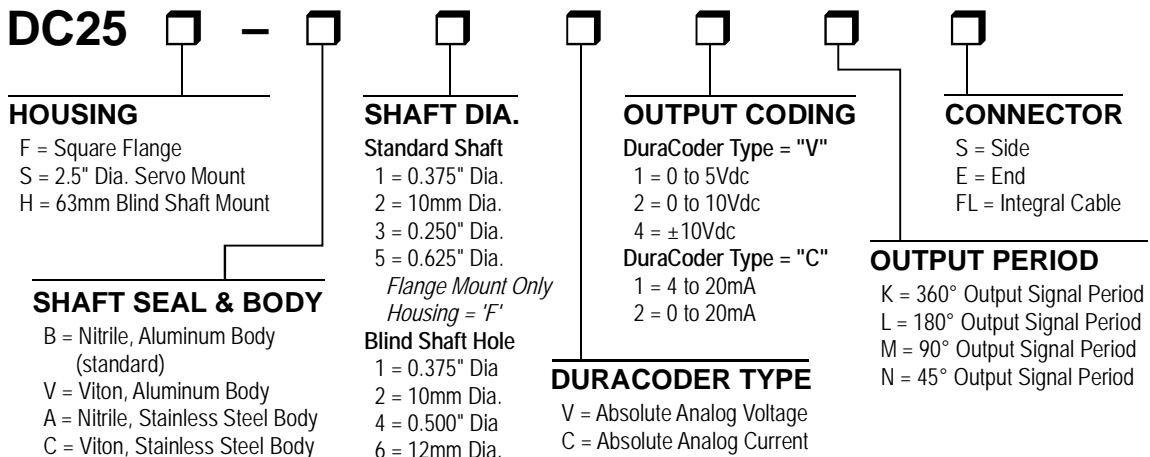

Figure 2 Part Number Description



**Electrical Specifications****Operating Voltage**

4.5 Vdc to 30 Vdc maximum

**Power Requirements**

1.8 W max.

58 mA @ 24 Vdc typical

Value is the operating power and does not include current supplied by the analog output.

**Position Resolution**

12 bit (4,096 counts) for 360° Output Period

11 bit (2,048 counts) for 180° Output Period

10 bit (1,024 counts) for 90° Output Period

9 bit (512 counts) for 45° Output Period

**Position Accuracy**

±10 arc-minutes

**Position Update Time**

20 microseconds

**Maximum Output Settling Time**

5 milliseconds when switching between minimum and maximum outputs

**Direction of Increasing Counts**

Default CW looking at shaft

Can be set to CCW increasing by shorting the Direction Control Input pin to DC Return.

**Zero Position**

Can be set by pulsing the Preset to Zero Input pin from DC Return to open circuit or +DC Power. Minimum pulse width of 100 milliseconds.

**Mechanical Specifications****Housing**

2.5" diameter powder coated aluminum or 316 stainless steel

**Mounting Style**

Industry standard size 25 flange, servo, or blind shaft. AMCI standard heavy duty face mount.

**Available Shafts**

Flange or Servo:

- 0.375" dia x 0.884" long
- 0.250" dia x 0.884" long
- 10 mm dia x 22.45 mm long

Blind Shaft:

- 0.375" dia x 1.10" deep
- 0.500" dia x 1.10" deep
- 10 mm dia x 27.9 mm deep
- 12 mm dia x 27.9 mm deep

AMCI standard face mount: 0.625" dia x 1.40" long. Length includes 1.50" dia x 0.125" pilot.

**Mechanical Specifications (continued)****Max. Starting Torque @ 25°C**

0.250", 0.375", or 10 mm shafts:

2.0 oz-in (1.41 N·cm):

All blind shafts:

6.0 oz-in (4.23 N·cm)

0.625" shaft:

6.0 oz-in (4.23 N·cm)

**Moment of Inertia**

0.250", 0.375", or 10 mm shafts:

6.00 X 10<sup>-4</sup> oz-in-sec<sup>2</sup> (43.2 X 10<sup>-6</sup> kg-cm-sec<sup>2</sup>)

All blind shafts:

7.00 X 10<sup>-4</sup> oz-in-sec<sup>2</sup> (50.4 X 10<sup>-6</sup> kg-cm-sec<sup>2</sup>)

0.625" shaft:

8.00 X 10<sup>-4</sup> oz-in-sec<sup>2</sup> (57.6 X 10<sup>-6</sup> kg-cm-sec<sup>2</sup>)

**Max. Operating Speed**

6000 RPM max.

**Max. Shaft Loading (0.625" shaft)**

Axial: 50 lbs. (222 N)

Radial: 100 lbs. (445 N)

At specified max. loads, minimum bearing life is 2X10<sup>9</sup> revolutions.

**Max. Shaft Loading (All other shafts)**

Axial: 20 lbs. (89 N)

Radial: 40 lbs. (178 N)

At specified max. loads, minimum bearing life is 2X10<sup>9</sup> revolutions.

**Connector Location**

Aluminum body: Side or End

Stainless steel body: Side

**Environmental Specifications****Operating Temperature**

-40°F to +185°F (-40°C to +85°C) for units with a connector.

-20°F to +175°F (-29°C to +80°C) for units with an integral cable. (Cable limited.)

**Shock**

50g, 11 millisecond duration

**Vibration**

20 g, 5 to 2000 Hz

**Enclosure Rating**

IP67

**Approximate Weight**

2.0 lbs. (0.91 kg) 0.625" shaft

1.4 lbs. (0.65 kg) All other shafts



## Output Waveforms

### Output Period

The figure below shows the four available Output Periods when you order an AMCI Analog DuraCoder. The Output Period can be viewed as the amount of rotation needed to achieve full scale output.

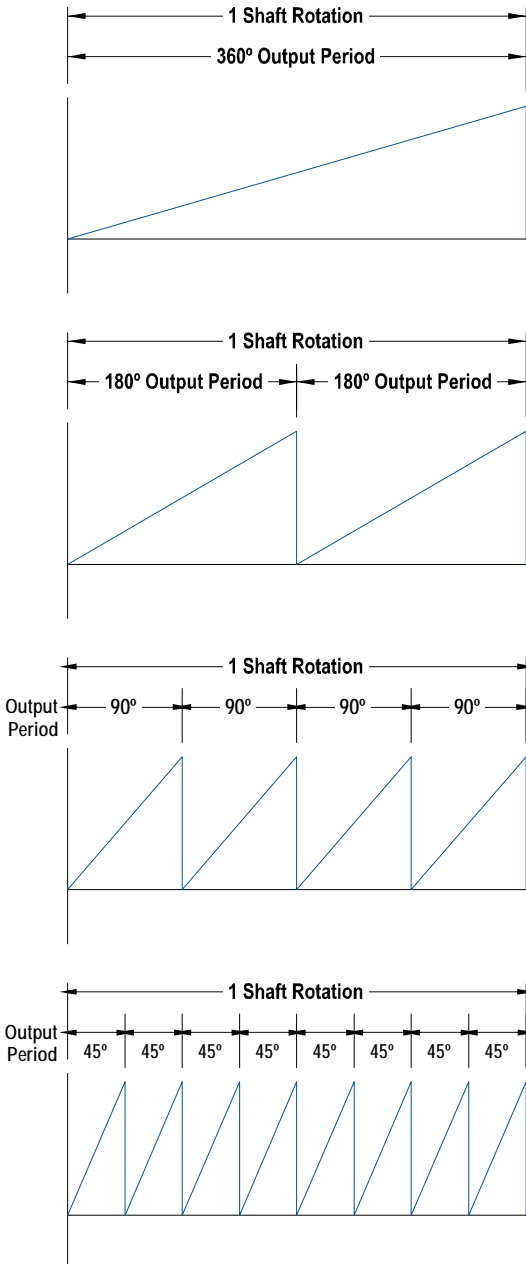

Figure 3 Output Periods

### Voltage Output Waveforms

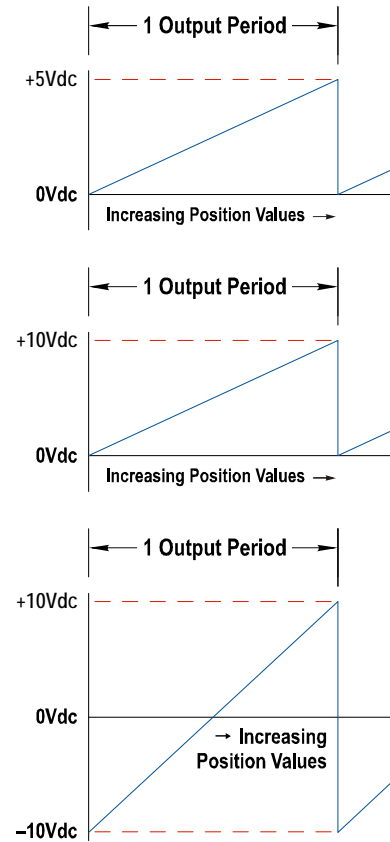

Figure 4 Available Voltage Outputs

### Current Output Waveforms

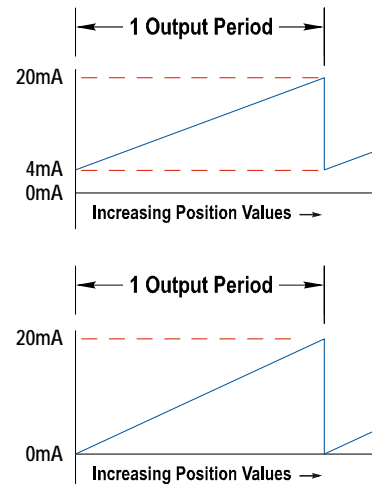

Figure 5 Available Current Outputs

**Output Load Calculations**

**Voltage Output DuraCoder**

A voltage output DuraCoder can drive an output load of 2 kΩ or greater. If the output load is greater than 10 kΩ, consider installing a 10 kΩ resistor in parallel with the input terminals for greater noise immunity.

**Current Output DuraCoder**

The maximum load that can be driven by a current output DuraCoder depends on the power supply voltage applied to the +DC Power Input. For input voltages up to 15 Vdc, the maximum load is 420 Ω. For input voltages greater than or equal to 15 Vdc, the formula for determining the maximum load is given below along with a simple graph of the curve.

$$R_{LOAD\_MAX} = \frac{(+DC\ Input\ Voltage) - 5Vdc}{0.020A}$$

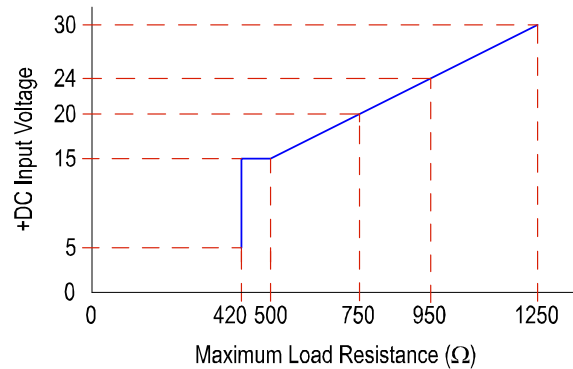

Figure 6 Maximum Load Resistance - Current Output

**Connector Pinouts**

**MS Connector - Aluminum Body**

The Analog DuraCoder uses an MS3102E18-1P connector. The pinout of this connector is shown below.

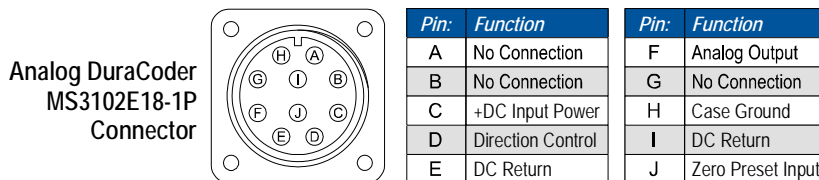

Figure 7 Connector Pinout

**Pins A, B, & G:** No Connection.

**Pin C: +DC Input Power:** Input pin to power the DuraCoder. Requires a 4.5 to 30Vdc power supply at 1.8W. This power draw does not include the current through the analog output.

**Pin D: Direction Control:** This pin controls which direction the shaft must rotate in to increase the analog output. With this pin open circuit, the output will increase with CCW rotation of the shaft. (While looking at the shaft.) Connecting this pin to Pin I forces the output to increase with CW rotation.



This pin must never be connected to Pin C (+DC Input Power)

The connection between Pin D and Pin I (DC Return), must be done at the DC25 Connector. Do not connect a pair of wires into a custom cable and connect these pins at the other end of this cable.

**Pins E and I: DC Return:** These two pins are internally tied together. Pin E is the used as the return for the analog signal and pin I is used as the return for the DC power supply.

**Pin F: Analog Output:** This pin is the analog output and it is referenced to Pin E, DC Return.

**Connector Pinouts (continued)**

**MS Connector - Aluminum Body (continued)**

**Pin H: Case Ground:** The DuraCoder body is usually connected to earth ground through its mounting. If the DuraCoder is mounted on a non-conductive surface, or not properly bonded to a painted metal surface, consider running a stranded wire from this pin and attach it to a solid ground point near the DuraCoder. Do not connect the cable shields or power supply common to this pin as doing so may cause a ground loop between the DuraCoder and the power supply or the signal input device.

**Pin J: Zero Preset Input:** This pin is internally tied high, but *not* directly to the +DC Power Input on pin C. Each time Pin J is pulled low by connecting it to DC Return (Pin I), the DuraCoder's output will be changed to its minimum value.

**CAUTION** This pin must never be connected to Pin C (+DC Input Power)

**NOTE**

- 1) Do not permanently tie Pin J to Pin I. The input must be released from DC Return before normal operation can resume.
- 2) Presetting the Analog DuraCoder's output causes a preset value to be stored in the DuraCoder's EEPROM memory. This memory has a maximum life of 100,000 write cycles. Therefore, presetting the output value every machine cycle should be avoided.

**M12 Connector - Stainless Steel Body**

An eight pin, A-coded, male M12 connector is used on these DC25 units. This connector is the Turck *eurofast* FS 8 or equivalent. The pinout for the connector is shown below.

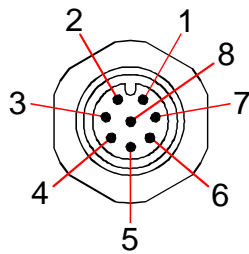

Turck FS 8 or equ.

Pin	Single Ended Outputs
1	+DC Power Input
2	Direction Control
3	Analog Return
4	No Connection
5	Analog Output
6	DC Return
7	Case Ground
8	Zero Preset Input

Figure 8 I/O Connector Pinout

**Pin 1: +DC Input Power:** Input pin to power the DuraCoder. Requires a 4.5 to 30Vdc power supply at 1.8W. This power draw does not include the current through the analog output.

**Pin 2: Direction Control:** This pin controls which direction the shaft must rotate in to increase the analog output. With this pin open circuit, the output will increase with CCW rotation of the shaft. (While looking at the shaft.) Connecting this pin to Pin 6 (DC Return) forces the output to increase with CW rotation.

**CAUTION** This pin must never be connected to Pin 1 (+DC Input Power)

The connection between Pin 2 and Pin 6 (DC Return), must be done as close to the DC25 as possible. If using an AMCI CNFL-5M cable, make the connections at the end of this cable. If adding an extension cable to the CNFL-5M, do not extend the wire from Pin 2.

**Pin 3: Analog Return:** A common return pin for both the analog signal and the DC power supply. If using twisted pair cabling, use this pin on the wire paired with the analog output connection.

**Connector Pinouts (continued)**

**M12 Connector - Stainless Steel Body (continued)**

**Pin 4: No Connection:** This pin can be left open if you are fabricating a custom cable. If a cordset, such as the CNFL-5M, is used, this pin should be tied to DC Return (pin 6) to prevent them from picking up any electrical noise in the environment.

**Pin 5: Analog Output:** This pin is the analog output and it is referenced to DC Return (pin 3).

**Pin 6: DC Return:** A common return pin for both the analog signal and the DC power supply. If using twisted pair cabling, use this pin on the wire paired with the +DC Power Input connection.

**Pin 7: Case Ground:** The DuraCoder body is usually connected to earth ground through its mounting. If the DuraCoder is mounted on a non-conductive surface, or not properly bonded to a painted metal surface, consider running a stranded wire from this pin and attach it to a solid ground point near the DuraCoder. Do not connect the cable shields or power supply common to this pin as doing so may cause a ground loop between the DuraCoder and the power supply or the signal input device.

**Pin 8: Zero Preset Input:** This pin is internally tied high, but *not* directly to the +DC Power Input on pin 1. Each time Pin 8 is pulled low by connecting it to DC Return (Pin 6), the DuraCoder’s output will be changed to its minimum value.

**CAUTION** This pin must never be connected to Pin 1 (+DC Input Power)

**NOTE**

- 1) *Do not* permanently tie Pin 8 to Pin 6. The input must be released from DC Return before normal operation can resume.
- 2) Presetting the Analog DuraCoder’s output causes a preset value to be stored in the DuraCoder’s EEPROM memory. This memory has a maximum life of 100,000 write cycles. Therefore, presetting the output value every machine cycle should be avoided.

**Mating Connector and Cordsets**

**MS Connector - Aluminum Body**

The following mating connector is for an aluminum bodied analog output DC25 available from AMCI.

AMCI #	Description
MSD-10	MS3106A18-1S, Amphenol # 97-3106A18-1S or equ. Solder cup connections. Straight, with cable clamp and rubber boot.

Table 1 Available Mating Connector

AMCI offers the following prewired cable for the aluminum bodied analog output DC25.

AMCI #	Description
CDCAV-(x)	Pre-wired MSD-10 with Belden 9730 or equ. (x) equals length in feet.

Table 2 Available Cordset

**Mating Connector and Cordsets (continued)**

**M12 Connector - Stainless Steel Body**

The following mating connector for a stainless steel analog output DC25 available from AMCI. Note that any commercially available M12 connectors with the proper coding and contacts can be used.

AMCI #	Description
MS-37	Female, A-coded, 8 contacts. Screw terminal connections. 6 to 8 mm dia. cable. Maximum 20 AWG wire dia. Straight, IP67 rated when properly installed.

Table 3 Available Mating Connector

AMCI offers the following cordset for use with the stainless steel analog output DC25.

AMCI #	Description
CNFL-5M	Molded cordset. 5 meters in length. Straight M12 8 pin A-coded to flying leads. IP67 rated when properly installed.

Table 4 Available Cordset

**Integral Cable Option**

Analog DC25 units are available with an integral 15 foot cable in place of a connector. The cable is Belden 9730 or equivalent. The cable contains three individually shielded twisted pairs. The outer cover is semi-ridge PVC.

The cable enters the unit through a submersible, continuous flex cord grip, McMaster-Carr part number 69915K64 or equivalent.

**NOTE**  Due to the materials used in the construction of the cable and cord grip, the environmental temperature rating for Analog DC25 units with the integral cable option is -20°F to +175°F. (-29°C to +80°C)

**Cable Colors**

Cable Color	Signal
Red	+DC Power Input
Black/Red†	DC Return
White	Analog Output
Black/White†	Analog Return
Green	Direction Control
Black/Green†	DC Return

† Black/(color) denotes black wire of black/color pair

Table 5 Integral Cable Color Code.

**Notes**

# REQUIRED TASK

## PHYSICAL INSTALLATION

This section is intended for the engineer or technician responsible for installing the DC25 resolver based encoder. Information in this chapter includes installation guidelines, links to online CAD files, and mechanical drawings.

### 1.1 Installation Guidelines

#### 1.1.1 Electrostatic Discharge Prevention

Electrostatic discharge can damage the DC25 if the discharge is through the I/O connector. Follow these guidelines when handling the unit.

- 1) Touch a grounded object to discharge static potential before handling the unit.
- 2) Work in a static-safe environment whenever possible.
- 3) Do not touch the pins of the I/O connector.
- 4) Do not disassemble the unit

#### 1.1.2 Suitable Environment

The DC25 has an IP67 environmental rating and can be installed in most industrial environments, including areas subject to washdown spray and temporary immersion.

**NOTE**  The IP67 rating is contingent on the proper installation of the mating connector and a functioning front seal.

#### 1.1.3 Shaft Loading

A flexible coupler should be used when connecting a DC25 to a drive shaft, because any mismatch in shaft alignment will result in large radial or axial loading on the shaft of the encoder. Limit shaft loading to the following values. These values statistically yield an L10 life of  $2 \times 10^9$  revolutions. (Statistically, only 10% of the bearings will have failed after  $2 \times 10^9$  revolutions.) Shaft loading has an exponential effect on bearing life. The effect is actually cubic. Cutting a shaft load in half will result in an eight fold increase in bearing life.

	Radial Load	Axial Load
0.625" shaft	100 lbs. (445N)	50 lbs. (222N)
All other shafts	40 lbs. (178 N)	20 lbs. (88 N)

Table 1.1 DC25 Maximum Shaft Loading Specifications

#### 1.1.4 A Note on Cable Direction

All of the dimensional drawings for stainless steel units show the direction that the cable exits when using right angle connectors. Use this information to properly route cables when designing the DC25 mounting.



**1.2 Outline Drawings**

*1.2.1 Flange Mount, Aluminum Body, End Connect*

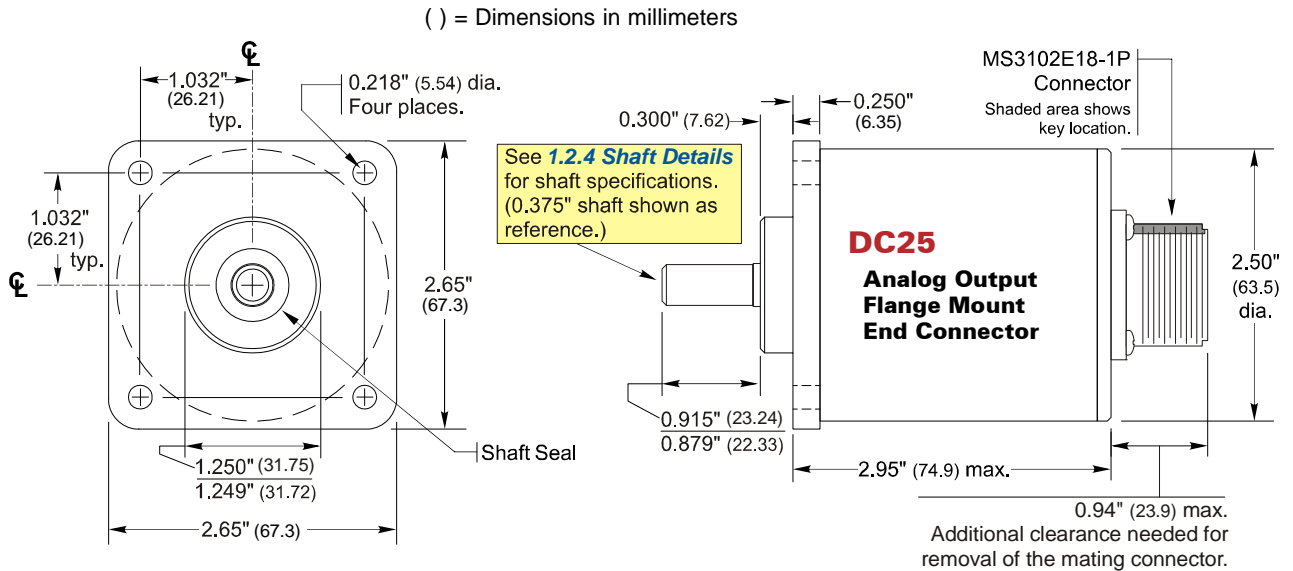

*1.2.2 Flange Mount, Aluminum Body, Side Connect*

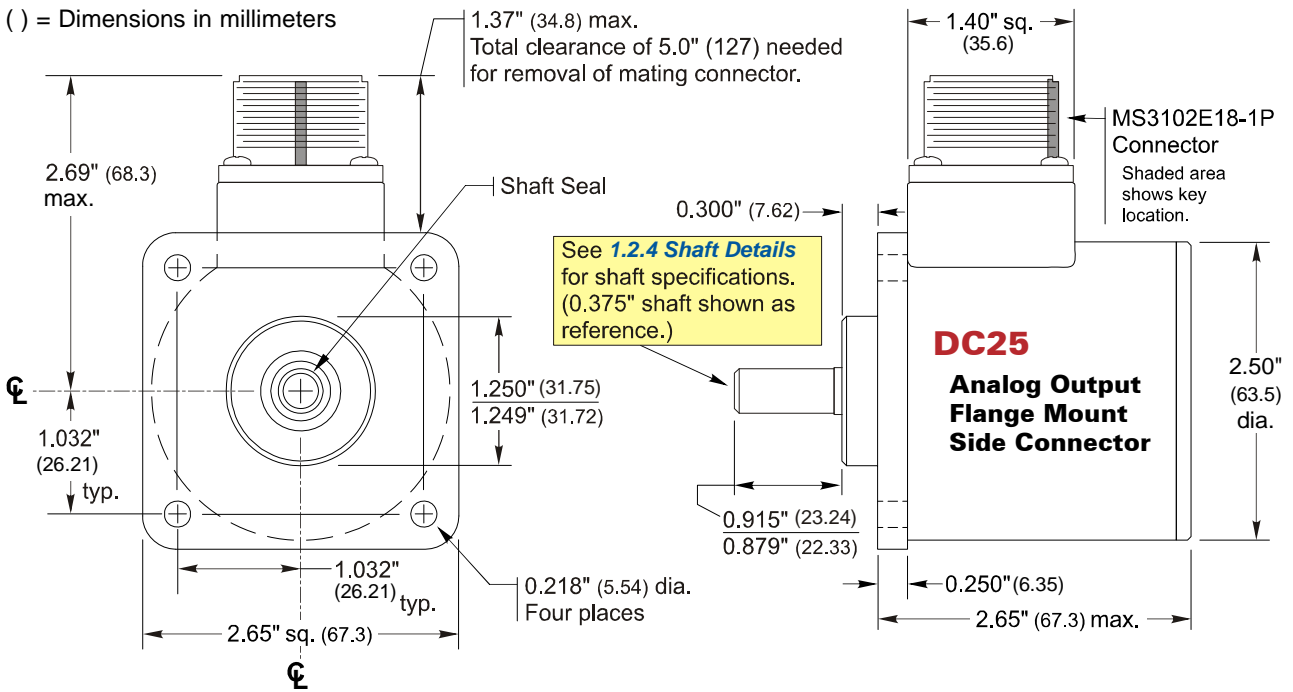

**1.2 Outline Drawings (continued)**

**1.2.3 Flange Mount, Stainless Steel Body, Side Connect**

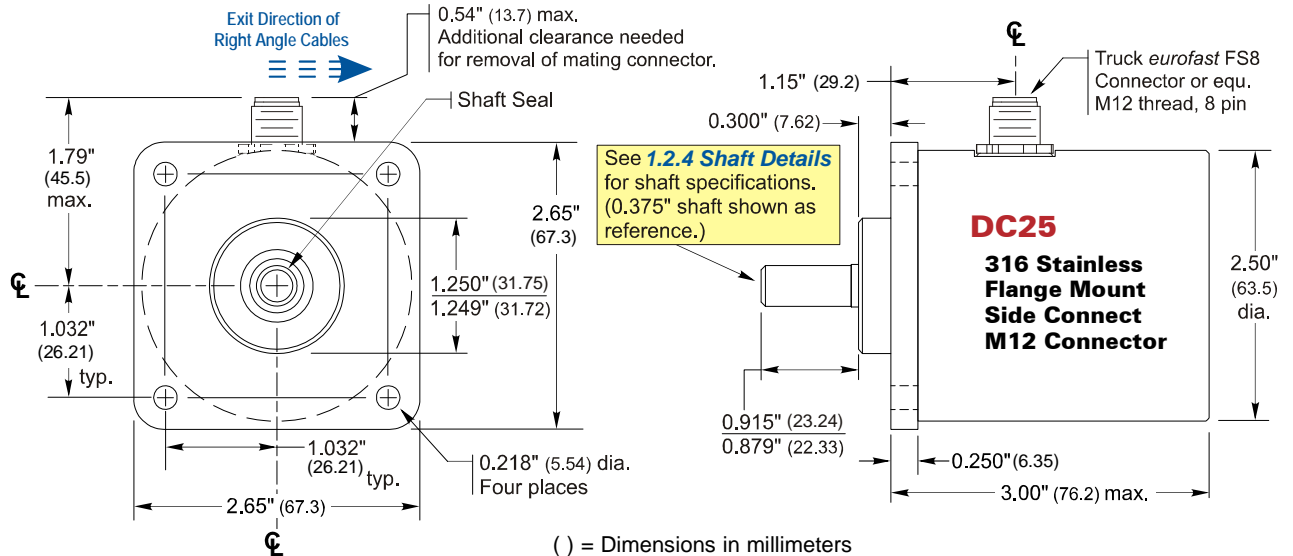

Figure 1.3 Outline Drawing: Flange Mount, Stainless Steel Body, Side Connector.

**1.2.4 Shaft Details - Flange Mount Option**

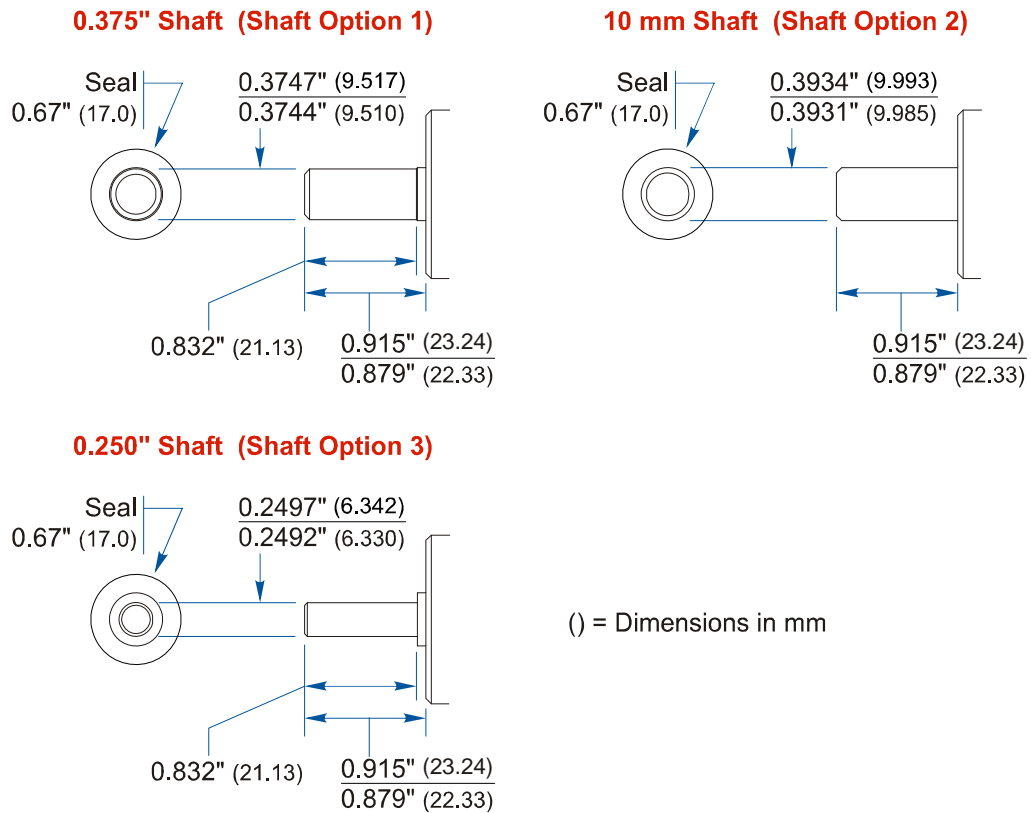

Figure 1.4 Shaft Details - Flange Mount

**1.2 Outline Drawings (continued)**

**1.2.5 Servo Mount, Aluminum Body, End Connect**

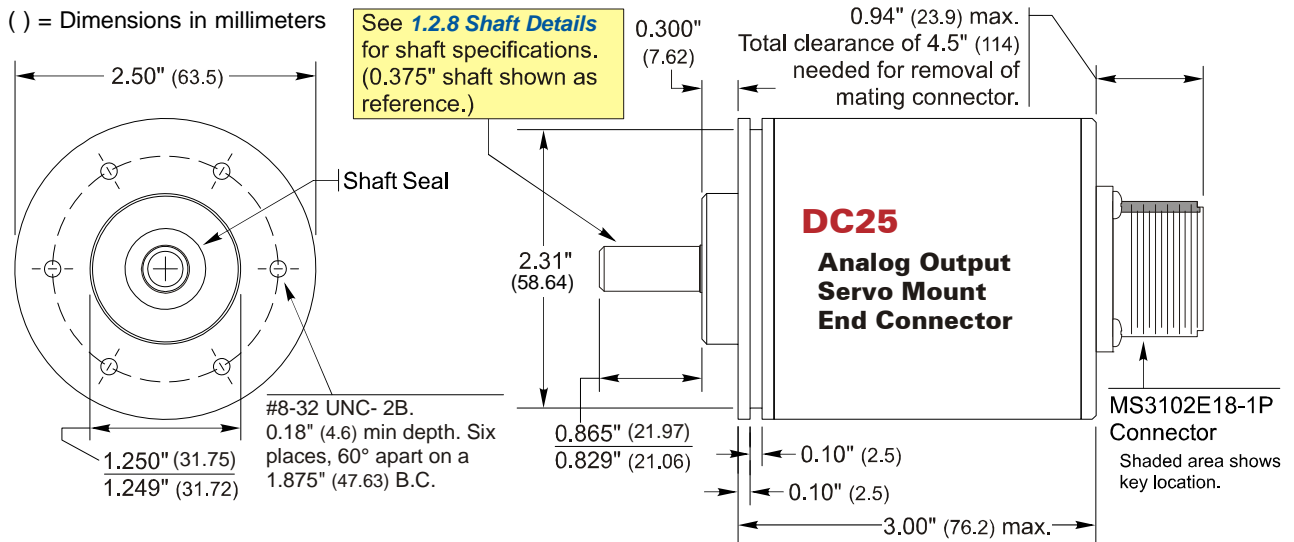

Figure 1.5 Outline Drawing: Servo Mount, Aluminum Body, End Connector.

**1.2.6 Servo Mount, Aluminum Body, Side Connect**

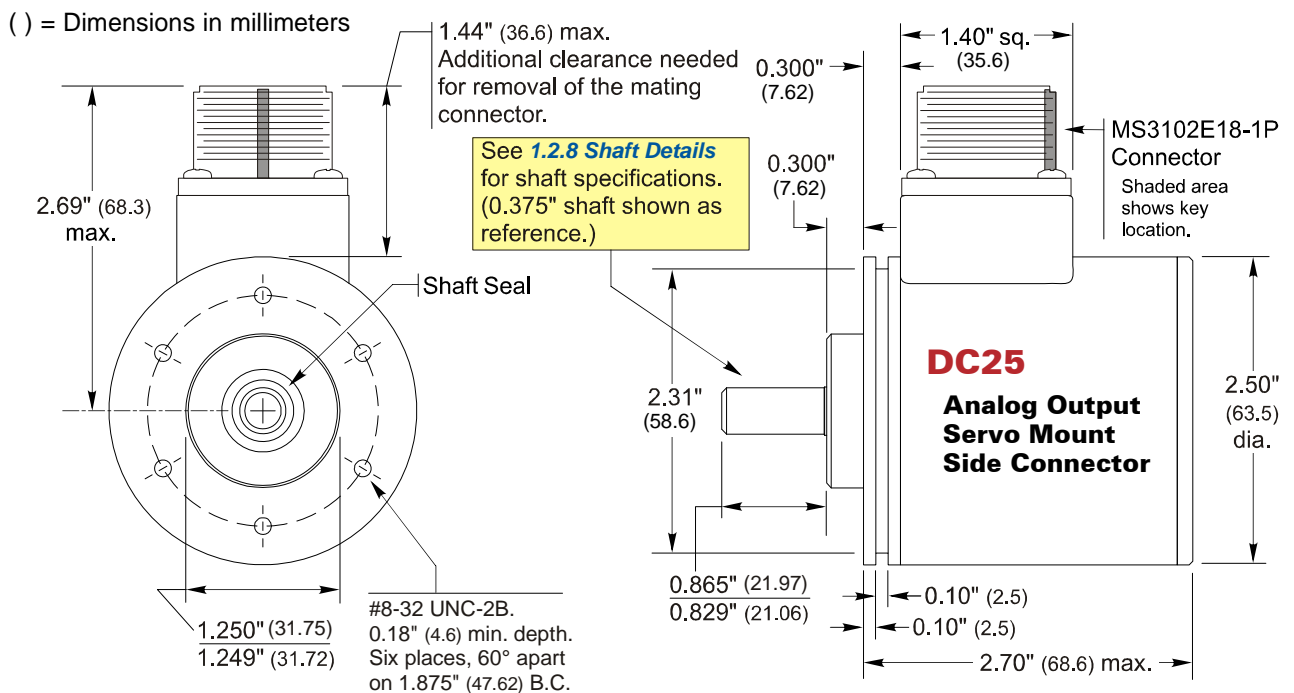

Figure 1.6 Outline Drawing: Servo Mount, Aluminum Body, Side Connector.

**1.2 Outline Drawings (continued)**

**1.2.7 Servo Mount, Stainless Steel Body, Side Connect**

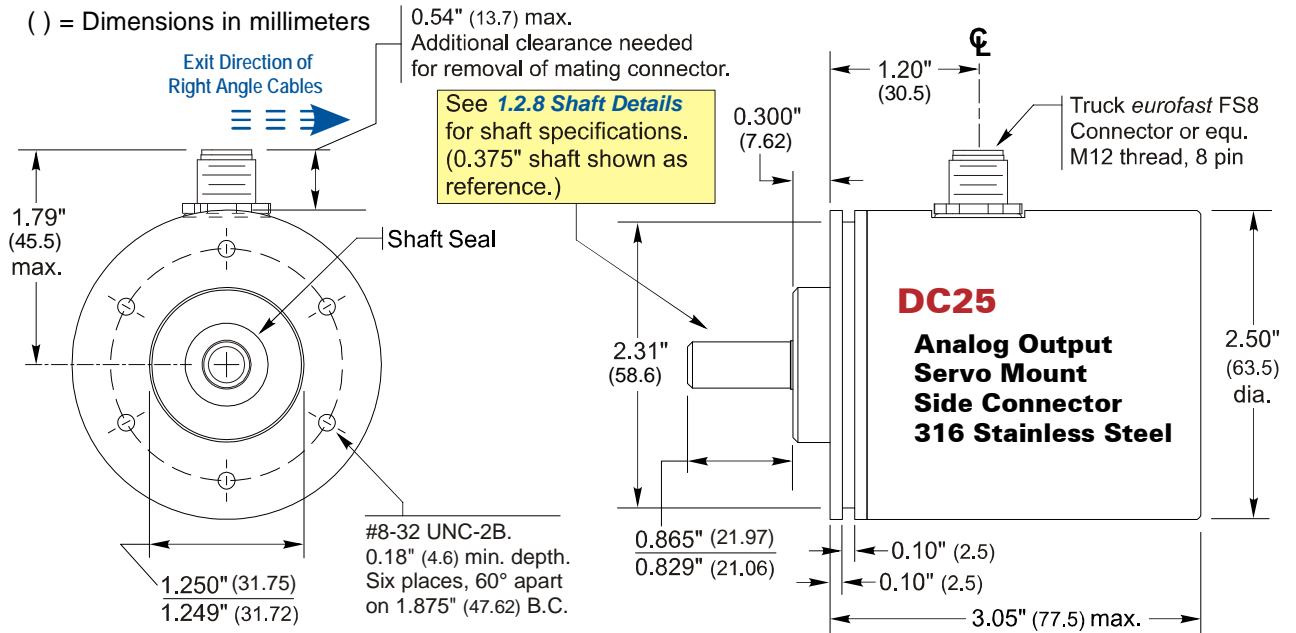
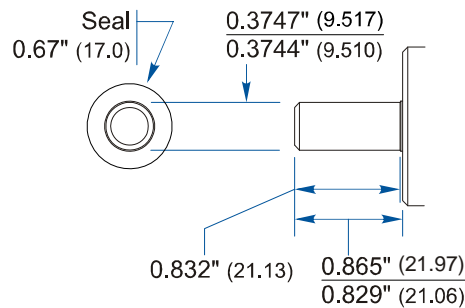

Figure 1.7 Outline Drawing: Servo Mount, Stainless Steel Body, Side Connector.

**1.2.8 Shaft Details - Servo Mount Option**

**0.375" Shaft (Shaft Option 1)**



**10 mm Shaft (Shaft Option 2)**

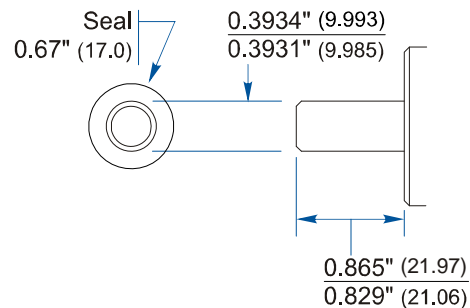

**0.250" Shaft (Shaft Option 3)**

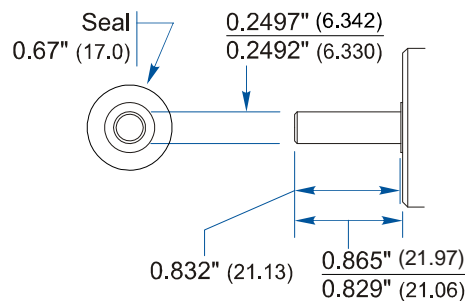

( ) = Dimensions in mm

Figure 1.8 Shaft Details - Servo Mount

**1.2 Outline Drawings (continued)**

*1.2.9 Hub Shaft Mount, Aluminum Body, End Connect*

( ) = Dimensions in millimeters

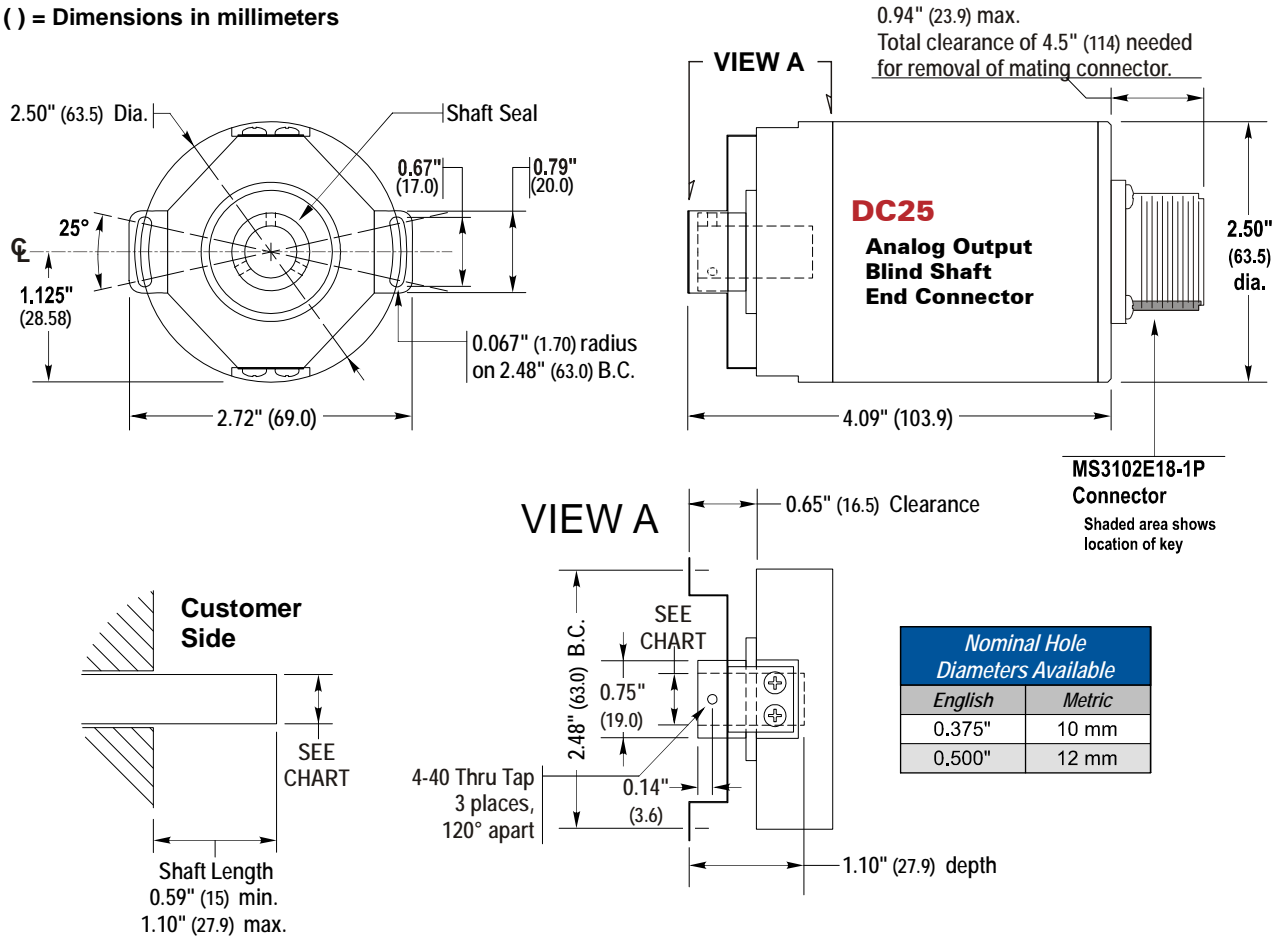

Figure 1.9 Outline Drawing: Hub Shaft Mount, Aluminum Body, End Connector.

**1.2 Outline Drawings (continued)**

**1.2.10 Hub Shaft Mount, Aluminum Body, Side Connect**

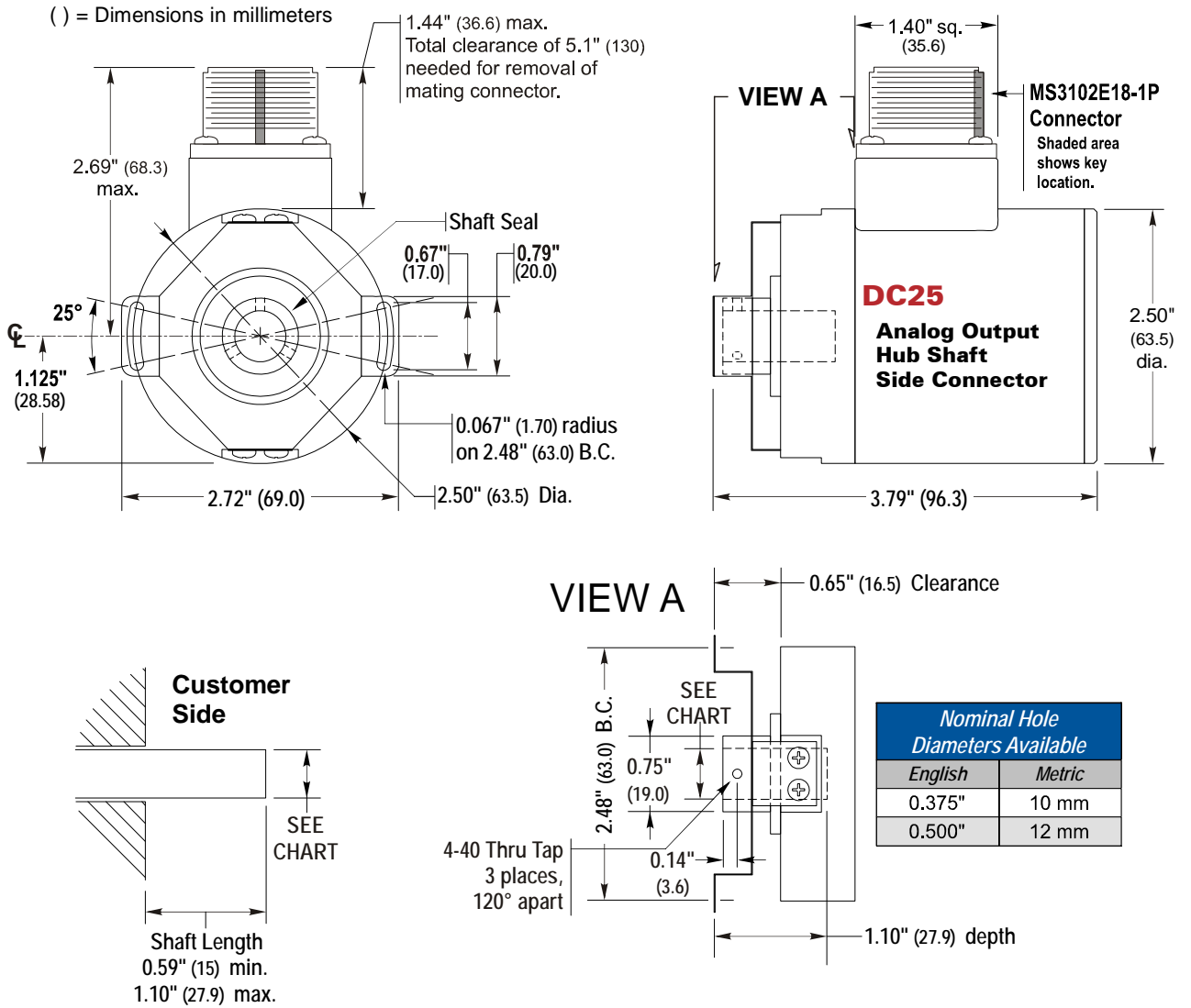

Figure 1.10 Outline Drawing: Hub Shaft Mount, Aluminum Body, Side Connector.

**1.2 Outline Drawings (continued)**

*1.2.11 Hub Shaft Mount, Stainless Steel Body, Side Connect*

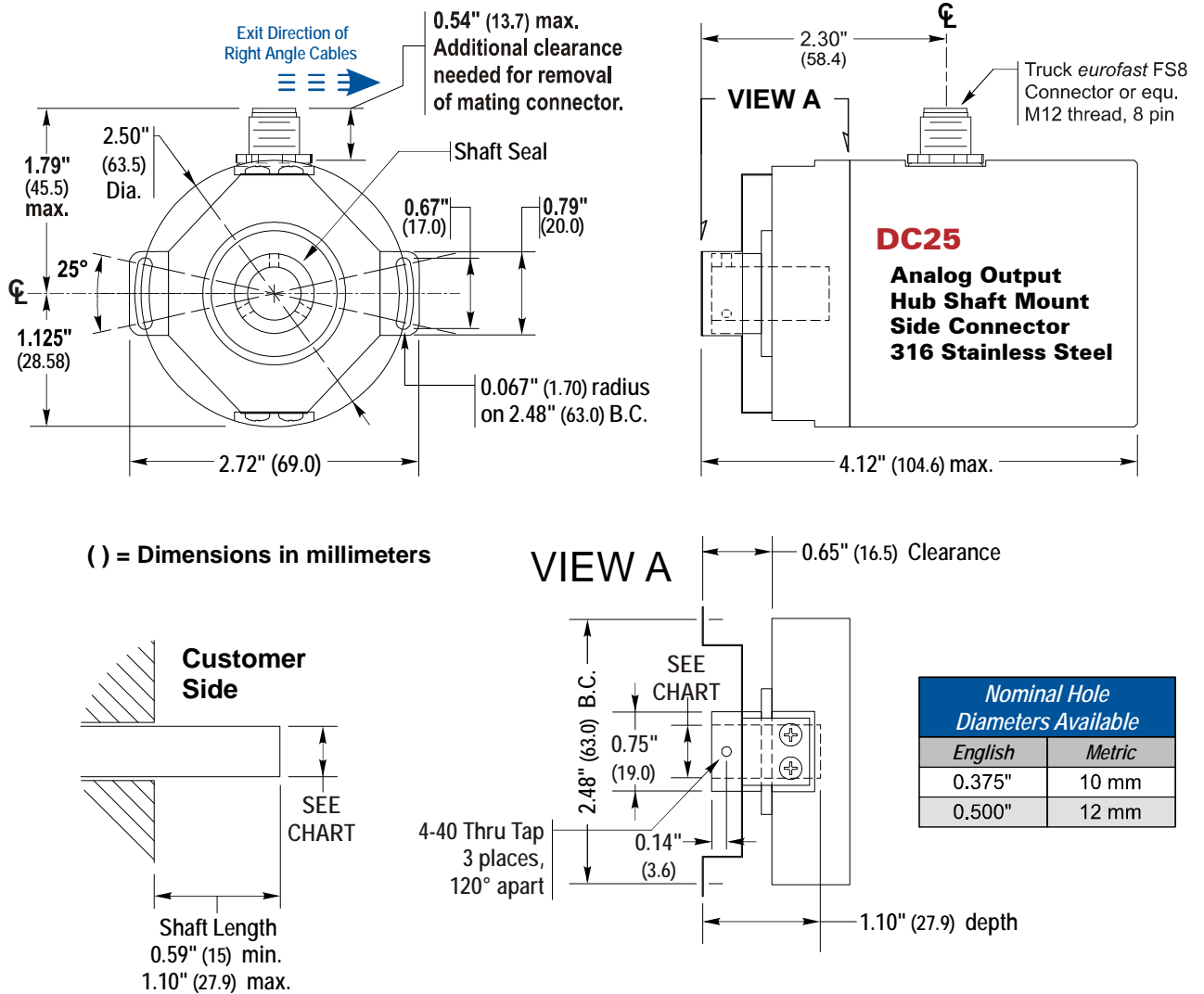

Figure 1.11 Outline Drawing: Hub Shaft Mount, Stainless Steel Body, Side Connector.



**1.2 Outline Drawings (continued)**

*1.2.12 5/8" Shaft, Face Mount, Aluminum Body, End Connect*

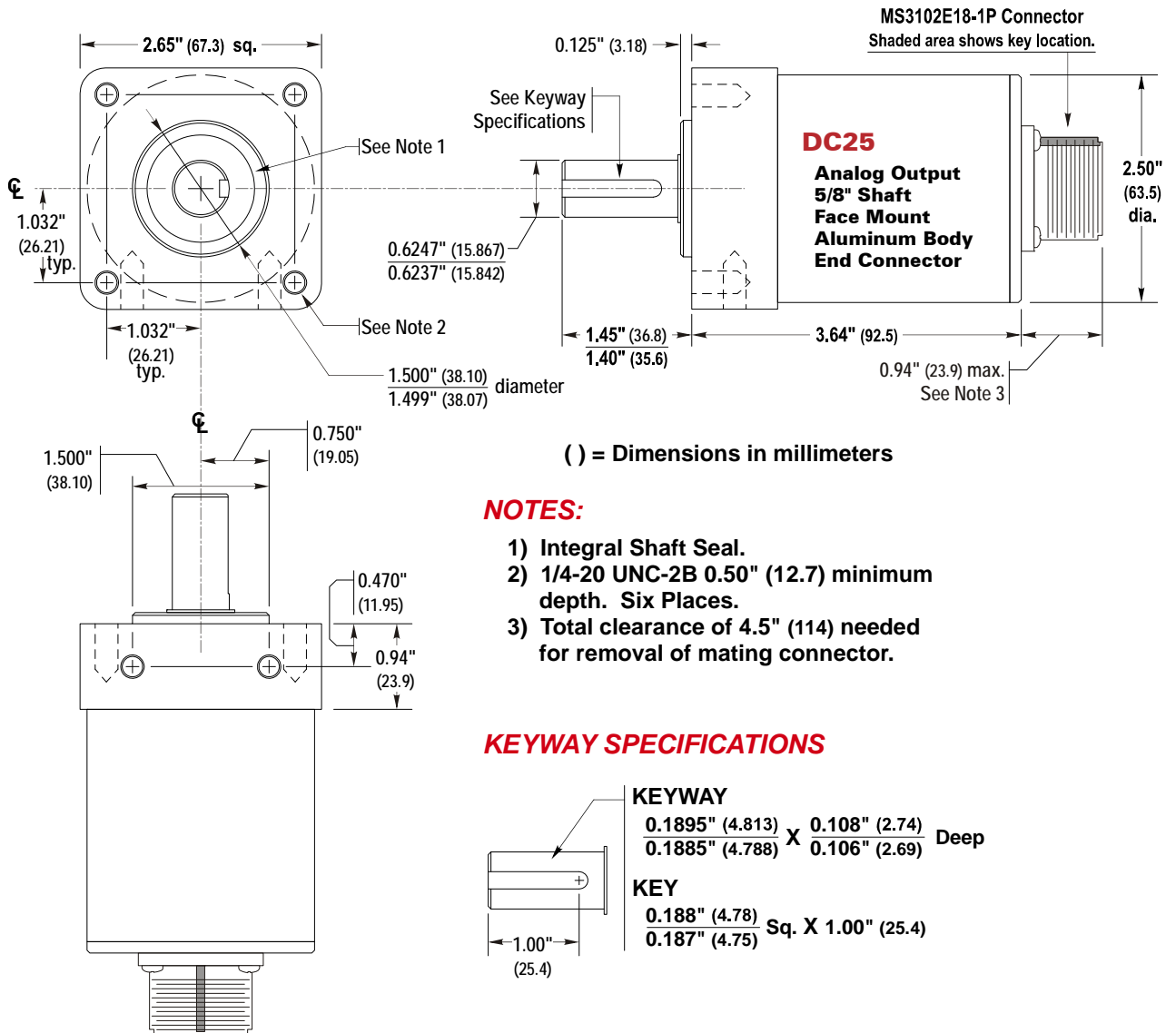

Figure 1.12 Outline Drawing: 5/8" Shaft, Face Mount, Aluminum Body, End Connector.

**1.2 Outline Drawings (continued)**

*1.2.13 5/8" Shaft, Face Mount, Aluminum Body, Side Connect*

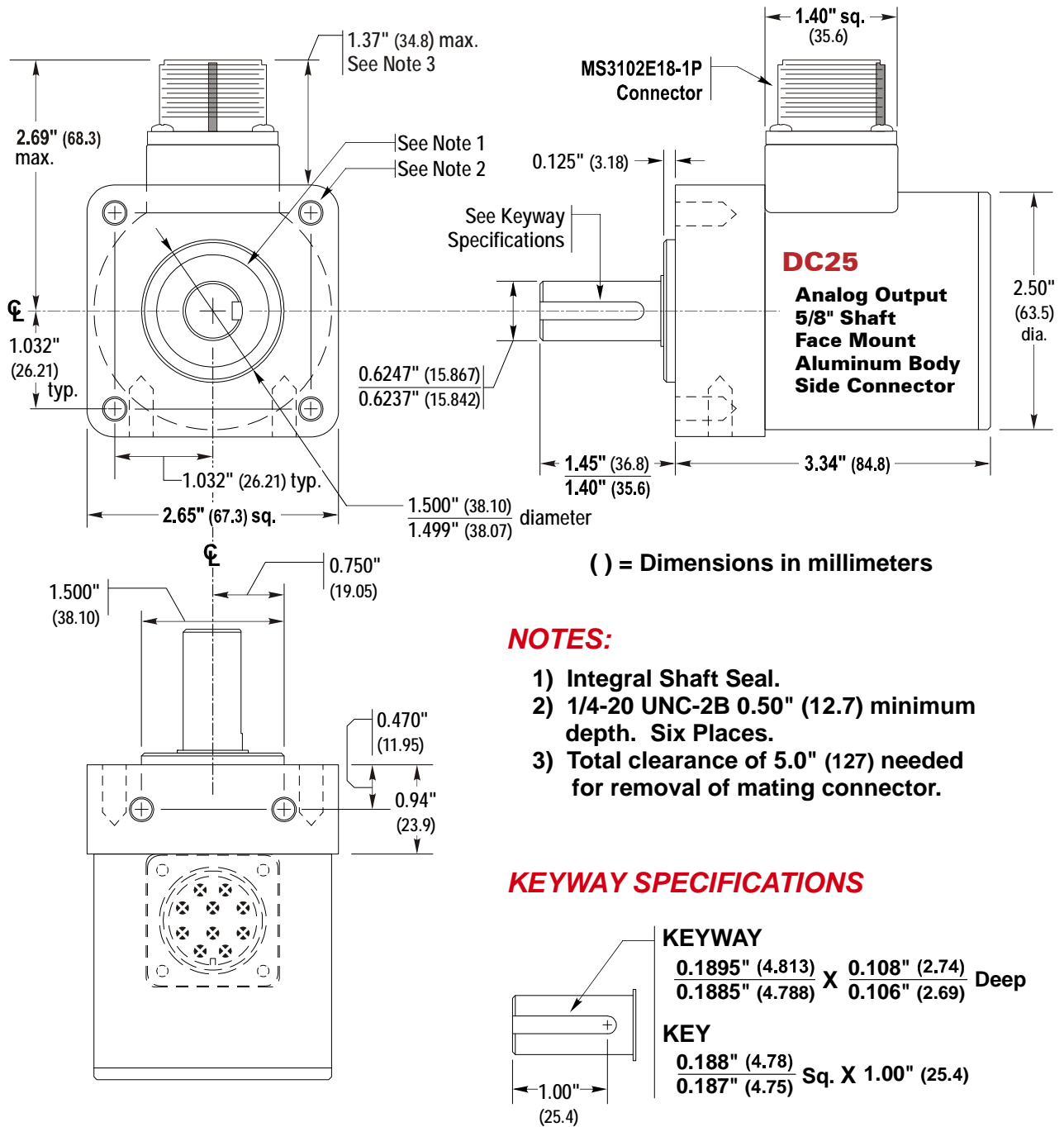

Figure 1.13 Outline Drawing: 5/8" Shaft, Face Mount, Aluminum Body, Side Connector.

**1.2 Outline Drawings (continued)**

*1.2.14 5/8" Shaft, Face Mount, Stainless Steel Body, Side Connect*

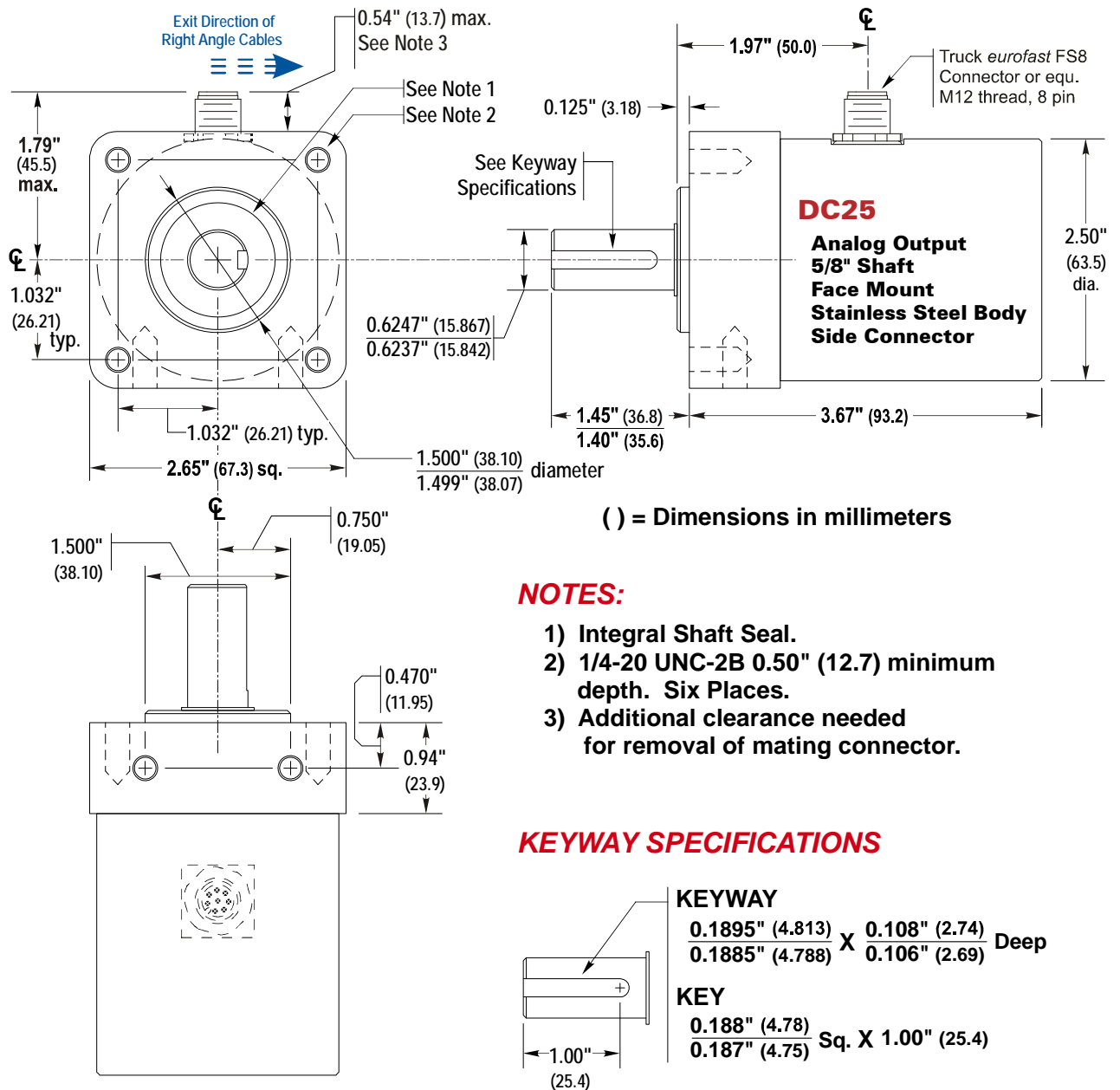

Figure 1.14 Outline Drawing: 5/8" Shaft, Face Mount, Stainless Steel Body, Side Connector.

**1.2 Outline Drawings (continued)**

*1.2.15 Integral Cable Option*

All aluminum bodied analog DC25 units have an integral cable option, where the cable comes axially off the back of the unit. The cable is fifteen feet in length. Figure 1.15 below shows the rear dimensions of a DC25 with the integral cable option.

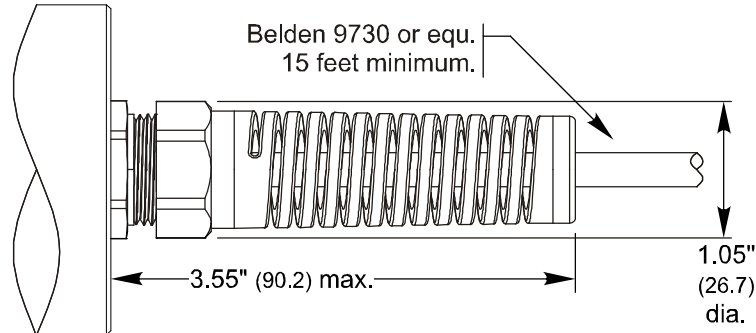

Figure 1.15 Integral Cable Option

# REQUIRED TASK

## WIRE POWER AND I/O

### 2.1 Wiring Guidelines

An analog DC25 requires a power supply of 4.5 to 30 Vdc, (5 to 24 Vdc nominally). Power requirement is 1.8 watts maximum, with 58 mA @ 24Vdc typical.

**NOTE** This power draw does not include the current through the analog output.

- Signals from the DC25 are low voltage, low power signals. Cables should not be run with high power AC or DC cabling.
- Signal cable can be run in conduits with other low power AC and DC signal cables. Ideally, cable will be run in metal conduit that is bonded along its entire length.
- Signal cable should not be run in parallel with high power AC or DC cabling to minimize capacitive coupling of electrical noise. If they must be run in parallel, separate them as much as possible.
- If a signal cable must cross high power AC or DC cabling, it should do so at a right angle to minimize inductive coupling of electrical noise.

### 2.2 Aluminum DC25 with MS Connector

#### 2.2.1 MS Connector Pinout

The aluminum bodied analog DuraCoders uses an MS3102E18-1P connector. The pinout of this connector is shown below.

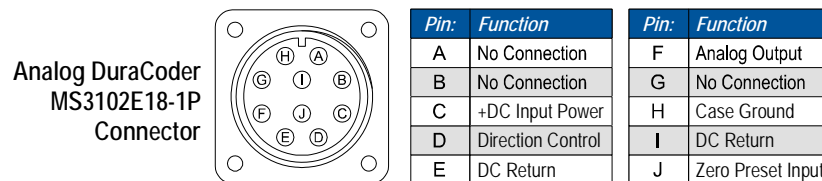

Figure 1 Connector Pinout

**Pins A, B, & G:** No Connection.

**Pin C: +DC Input Power:** Input pin to power the DuraCoder. Requires a 5 to 30Vdc power supply at 1.5W. This power draw does not include the current through the analog output.

**Pin D: Direction Control:** This pin controls which direction the shaft must rotate in to increase the analog output. With this pin open circuit, the output will increase with CCW rotation of the shaft. (While looking at the shaft.) Connecting this pin to Pin I forces the output to increase with CW rotation.

**CAUTION**

This pin must never be connected to Pin C (+DC Input Power)

The connection between Pin D and Pin I (DC Return), must be done at the DC25 Connector. Do not connect a pair of wires into a custom cable and connect these pins at the other end of this cable.

**Pins E and I: DC Return:** These two pins are internally tied together. Pin E is the used as the return for the analog signal and pin I is used as the return for the DC power supply.

**Pin F: Analog Output:** This pin is the analog output and it is referenced to Pin E, DC Return.

**2.2 Aluminum DC25 with MS Connector (continued)**

*2.2.1 MS Connector Pinout (continued)*

**Pin H: Case Ground:** The DuraCoder body is usually connected to earth ground through its mounting. If the DuraCoder is mounted on a non-conductive surface, or not properly bonded to a painted metal surface, consider running a stranded wire from this pin and attach it to a solid ground point near the DuraCoder. Do not connect the cable shields or power supply common to this pin as doing so may cause a ground loop between the DuraCoder and the power supply or the signal input device.

**Pin J: Zero Preset Input:** This pin is internally tied high, but *not* directly to the +DC Power Input on pin C. Each time Pin J is pulled low by connecting it to DC Return (Pin I), the DuraCoder’s output will be changed to its minimum value.

**⚠ CAUTION** This pin must never be connected to Pin C (+DC Input Power)

**NOTE** ⚠

- 1) *Do not* permanently tie Pin J to Pin I. The input must be released from DC Return before normal operation can resume.
- 2) Presetting the Analog DuraCoder’s output causes a preset value to be stored in the DuraCoder’s EEPROM memory. This memory has a maximum life of 100,000 write cycles. Therefore, presetting the output value every machine cycle should be avoided.

*2.2.2 Right Angle Cable Exit Direction*

When designing a mounting solution for the DC25, be aware of the cable exit direction when using right angle mating connectors. The outline drawings on pages 14 through 23 show the location of the connector key in the aluminum bodied DuraCoders. Many right angled MS mating connectors can be assembled with the cable exiting in one of four directions relative to the key.

*2.2.3 AMCI Mating Connector and Cable*

The following mating connectors and cables are available from AMCI.

AMCI #	Description
MSD-10	MS3106A18-1S Connector. Solder cup connections. 0.56" dia. cable max. Straight, IP67 rated when properly installed.
CDCAV-(x)	Factory assembled cable. (x) = length in feet. Assembled with MSD-10 connector and Belden 9730 cable, or equivalent.

Table 2.1 Available Connector and Cable

2.2 Aluminum DC25 with MS Connector (continued)

2.2.4 Sample Wiring Diagram

The wiring diagram below is for a CDCAV-(x) cable manufactured by AMCI. The wiring diagram should be followed if you are making your own cable using the MSD-10 connector.

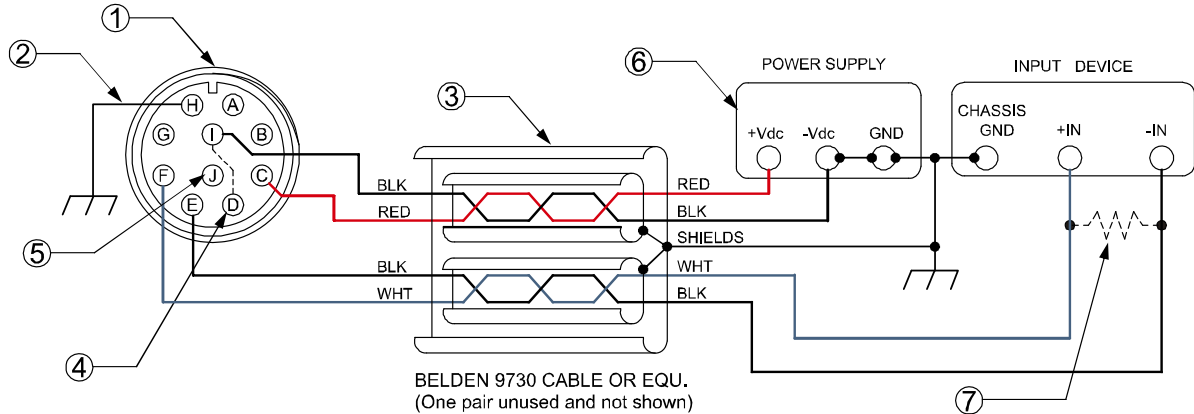

Figure 2.2 CDCAV-(x) Wiring Diagram

- 1) Connector Type: MS3106A18-1S AMCI Part Number: MSD-10
- 2) The case of the DuraCoder must be connected to Earth Ground. This is usually accomplished through its mounting. If not properly grounded through its mounting, a wire from Pin H must be connected to an Earth Ground point as close as possible to the DuraCoder. Do Not connect Pin H to the cable shields or power supply common. This can form a ground loop that may affect the operation of the DuraCoder.
- 3) CDCAV-x cable is made by AMCI with Belden 9730 cable or an exact equivalent. The 9730 is a three pair cable and the additional pair is cut off inside the jacket and left electrically isolated from the other pairs. If you are making your own cable, Belden 9729, which is a two pair cable, can be used in place of the 9730. See the notes associated with point 4 below.
- 4) Units are shipped with CCW increasing output when looking at the shaft. For CW increasing output, jumper Pin D to Pin I at the connector.

**NOTE** If you are making your own cable, and its length is fifteen feet or less, you can connect the unused green/black pair of the Belden 9730 cable to pins D and I and make the count direction connection outside of the connector. (This is the way the FL option is wired.) Do not exceed a fifteen foot cable length when doing this. This prevents noise from being injected into the pair that may affect operation.

- 5) Each time Pin J detects a transition from open circuit to DC Return (Pin I), the DuraCoder's output will be changed to its minimum value. To be changed, Pin J must be connected to Pin I for a minimum of 100 milliseconds.

**NOTE**

- A) Do not permanently tie Pin J to Pin I. If you do, the DuraCoder will reset the output to its minimum value on every power up.
- B) Presetting the Analog DuraCoder's output causes a preset value to be stored in the DuraCoder's EEPROM memory. This memory has a maximum life of 100,000 write cycles. Therefore, presetting the output value every machine cycle should be avoided.

- 6) Use a regulated power supply with a voltage output in the range of 7 to 30Vdc. If the cable length is less than 30 feet, a power supply of 5 to 30Vdc can be used.
- 7) For voltage output DuraCoders, (DC25x-xxVxxx), the input device impedance must be greater than 2 kilohms. If the input impedance exceeds 10 kilohms, consider installing a 10 kilohm resistor in parallel with the input terminals to improve the output's noise immunity.



## 2.3 Stainless Steel DC25 with M12 Connector

### 2.3.1 M12 Connector Pinout

An eight pin, A-coded, male M12 connector is used on these DC25 units. This connector is the Turck *eurofast* FS 8 or equivalent. The pinout for the connector is shown below.

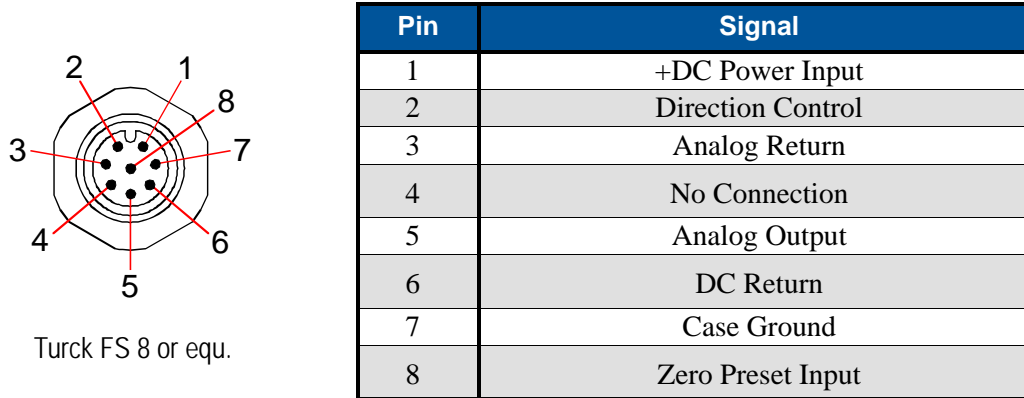

Figure 3 I/O Connector Pinout

**Pin 1: +DC Input Power:** Input pin to power the DuraCoder. Requires a 5 to 30Vdc power supply at 1.5W. This power draw does not include the current through the analog output.

**Pin 2: Direction Control:** This pin controls which direction the shaft must rotate in to increase the analog output. With this pin open circuit, the output will increase with CCW rotation of the shaft. (While looking at the shaft.) Connecting this pin to Pin 6 (DC Return) forces the output to increase with CW rotation.



This pin must never be connected to Pin 1 (+DC Input Power)

The connection between Pin 2 and Pin 6 (DC Return), must be done as close to the DC25 as possible. If using an AMCI CNFL-5M cable, make the connections at the end of this cable. If adding an extension cable to the CNFL-5M, do not extend the wire from Pin 2.

**Pin 3: Analog Return:** A common return pin for both the analog signal and the DC power supply. If using twisted pair cabling, use this pin on the wire paired with the analog output connection.

**Pin 4: No Connection:** This pin can be left open if you are fabricating a custom cable. If a cordset, such as the CNFL-5M, is used, this pin should be tied to DC Return (pin 6) to prevent them from picking up any electrical noise in the environment.

**Pin 5: Analog Output:** This pin is the analog output and it is referenced to DC Return (pin 3).

**Pin 6: DC Return:** A common return pin for both the analog signal and the DC power supply. If using twisted pair cabling, use this pin on the wire paired with the +DC Power Input connection.

**Pin 7: Case Ground:** The DuraCoder body is usually connected to earth ground through its mounting. If the DuraCoder is mounted on a non-conductive surface, or not properly bonded to a painted metal surface, consider running a stranded wire from this pin and attach it to a solid ground point near the DuraCoder. Do not connect the cable shields to this pin as doing so may cause a ground loop between the DuraCoder and the power supply or the signal input device.

**2.3 Stainless Steel DC25 with M12 Connector (continued)**

*2.3.1 M12 Connector Pinout (continued)*

**Pin 8: Zero Preset Input:** This pin is internally tied high, but *not* directly to the +DC Power Input on pin 1. Each time Pin 8 is pulled low by connecting it to DC Return (Pin 6), the DuraCoder’s output will be changed to its minimum value.



This pin must never be connected to Pin 1 (+DC Input Power)



- 1) *Do not* permanently tie Pin 8 to Pin 6. The input must be released from DC Return before normal operation can resume.
- 2) Presetting the Analog DuraCoder’s output causes a preset value to be stored in the DuraCoder’s EEPROM memory. This memory has a maximum life of 100,000 write cycles. Therefore, presetting the output value every machine cycle should be avoided.

*2.3.2 Right Angle Cable Exit Direction*

When designing a mounting solution for the DC25, be aware of the cable exit direction when using right angle mating connectors. The stainless steel outline drawings on pages 14 through 23 show the direction the cable exits the DC25 relative to the front view of the unit.

*2.3.3 AMCI Mating Connector and Cordset*

AMCI offers the following mating connector and cordsets that mate with the DC25 connectors. Note that the power connector will mate with any connector or cordset that follows the M12, 4 pin, A-coded standard.

AMCI #	Description
MS-37	Screw terminal connections. 6 to 8 mm dia. cable. 20 AWG max. Straight, IP67 rated when properly installed.
CNFL-5M	Molded cordset. 5 meters in length. Straight M12 8 pin A-coded to flying leads IP67 rated when properly installed.

Table 2.2 Compatible Connector and Cordset Available from AMCI

2.3 Stainless Steel DC25 with M12 Connector (continued)

2.3.4 Sample Wiring Diagram

The diagram below shows how to wire a DC25 encoder using the CNFL-5M cable from AMCI.

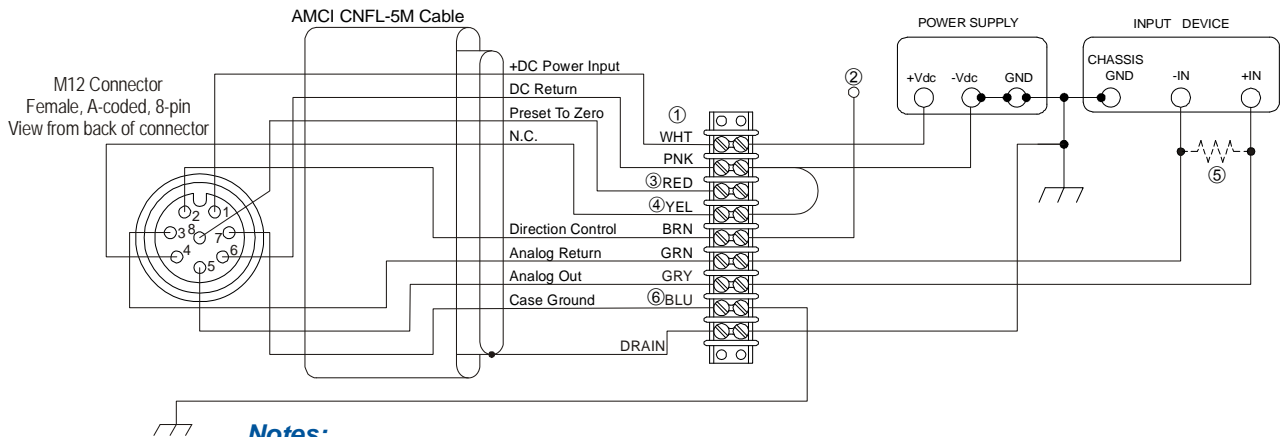

Notes:

- ① Color code is for the CNFL-5M cable available from AMCI.
- ② The Direction Control pin should be tied to +DC Power for CW increasing output or DC Return for CCW increasing output.
- ③ Do not attach the Preset to Zero pin to +DC Power Input. Pulse this pin to DC Return to zero the analog output.
- ④ The N.C. (No Connection) pin should be grounded for normal operation.
- ⑤ For voltage output, if input impedance exceeds 10 kohm, consider installing a 10 kohm resistor to improve noise immunity.
- ⑥ If the DC25 is not properly grounded through its mounting, run a strained wire from this pin to an earth ground point near DC25. If the DC25 is properly grounded through its mounting, this pin can be isolated.

Figure 2.4 Sample Wiring Diagram

**2.4 Integral Cable (FL option)**

All aluminum bodied analog DC25 units have an integral cable option, where the cable comes axially off the back of the unit. The cable is fifteen feet in length. Figure 1.15 below shows the rear dimensions of a DC25 with the integral cable option.

**NOTE** ⚠ Due to the materials used in the construction of the cable and cord grip, the environmental temperature rating for Analog DC25 units with the integral cable option is  $-20^{\circ}\text{F}$  to  $+175^{\circ}\text{F}$ . ( $-29^{\circ}\text{C}$  to  $+80^{\circ}\text{C}$ )

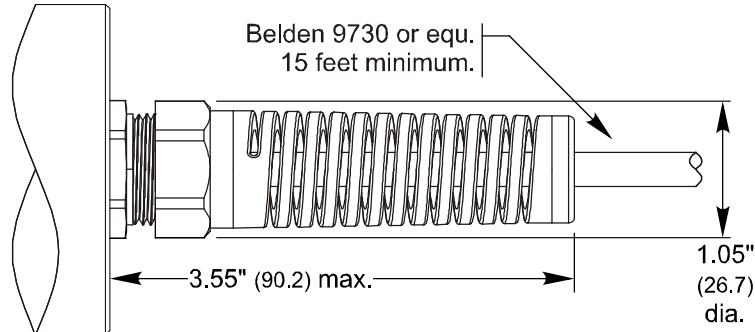

Figure 2.5 Integral Cable Option

2.4.1 Cable Pinout

Cable Color	Signal
Red	+DC Power Input
Black/Red <sup>†</sup>	DC Return
White	Analog Output
Black/White <sup>†</sup>	Analog Return
Green	Direction Control
Black/Green <sup>†</sup>	DC Return

<sup>†</sup> Black/(color) denotes black wire of black/color pair

Table 3 Integral Cable Color Code.

2.4 Integral Cable (FL option) (continued)

2.4.2 Sample Wiring Diagram

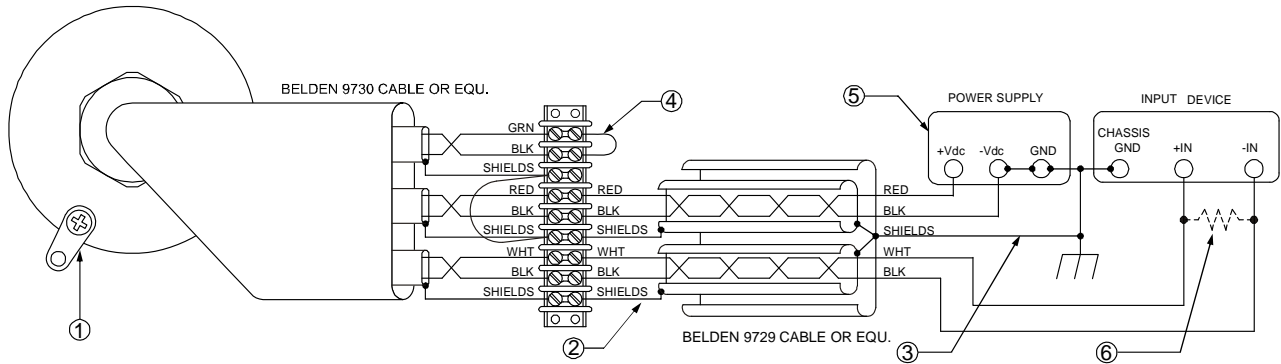

Figure 2.6 FL Wiring Diagram

- 1) The DuraCoder case must be connected to earth ground. This is usually accomplished through its mounting. If not properly grounded through its mounting, a wire from the grounding lug must be connected to an earth ground point as close as possible to the DuraCoder. *Do not* connect the shields to the ground lug. This can form a ground loop that may affect the operation of the DuraCoder.
- 2) If your extension cable has individually shielded twisted pairs, treating each shield in the FL cable and your extension cable as separate signal carrying conductors. *Do not* tie them together at the junction box. This will result in the greatest noise immunity in the system. If your extension cable has only a single overall shield, connect all of the shields of the FL cable to this shield. *Do not* ground the shields at the junction box.
- 3) Ground the shield of the cable at the power supply earth ground only. Grounding the shields at multiple points along the run may cause ground loops that may affect operation or damage the system.
- 4) Each analog DuraCoder ships with CCW increasing output when looking at the shaft. For CW increasing output, short the Direction pair, (Green/Black), together at the cable junction. *Do not* extend the Direction pair.
- 5) Use a regulated power supply with a voltage range of 7 to 24 Vdc. If the total cable length is less than thirty feet, a power supply of 5 to 24 Vdc can be used.
- 6) For voltage output DuraCoders, the input device impedance must be greater than two kilohm. If the input device impedance exceeds ten kilohm, consider installing a ten kilohm resistor in parallel with the input terminals. This will increase the noise immunity of the voltage signal.

**Notes**



***ADVANCED MICRO CONTROLS INC.***

20 GEAR DRIVE, TERRYVILLE, CT 06786 T: (860) 585-1254 F: (860) 584-1973

---

[www.amci.com](http://www.amci.com)

---

***LEADERS IN ADVANCED CONTROL PRODUCTS***